



(Project Number: 945 041)



DELIVERABLE D5.1

Proceedings of the GFR Summer School

Lead Beneficiary: CENTRUM VYZKUMU REZ

Due date: 30/11/2021

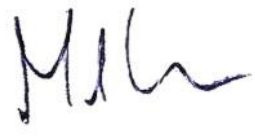
Released on: 04/10/2022

Authors:	Tomáš Melichar	
For the Lead Beneficiary	Reviewed by Work package Leader	Approved by Coordinator
Tomáš MELICHAR 	Eugene SHWAGER AUS 	Branislav HATALA 

Start date of project:

01/10/2020

Duration: **48 Months**

Project Coordinator:

Branislav Hatala

Project Coordinator Organisation:

VUJE, a. s.

VERSION: **1.1**

Project co-funded by the European Commission under the Euratom Research and Training Programme on Nuclear Energy within the Horizon 2020 Programme

Dissemination Level

PU	Public	X
RE	Restricted to a group specified by the Beneficiaries of the MEET-CINCH project	
CO	Confidential, only for Beneficiaries of the MEET-CINCH project	

Version control table

Version number	Date of issue	Author(s)	Brief description of changes made
0.1	15.9.2022	Tomas Melichar	First version (not reviewed)
1.0	29.09. 2022	Eugene Shwageraus	Reviewed by WP leader
1.1	4.10.2022	Slavomir Bebjak Jakub Heller	Reviewed by MST Final version

Project information

Project full title:	Safety of GFR through innovative materials, technologies and processes
Acronym:	SafeG
Funding scheme:	Research and innovation action
ECGA number:	945041
Programme and call	Horizon 2020 Framework Programme for Research and Innovation (2014-2020) NFRP-2019-2020 (Nuclear Fission and Radiation Protection Research)
Coordinator:	Dr. Branislav Hatala
EC Project Officer:	Dr. Cristina Fernandez Ramos
Start date – End date:	01/10/20 – 30/09/2024 i.e. 48 months
Coordinator contact:	+421 905 567 985, branislav.hatala@vuje.sk
Administrative contact:	+420 602 771 784, jakub.heller@evalion.cz
Online contacts (website):	www.safeg.eu

Copyright

The document is proprietary of the SafeG consortium members. No copying or distributing, in any form or by any means, is allowed without the prior written agreement of the owner of the property rights. This document reflects only the authors' view. The European Community is not liable for any use that may be made of the information contained herein.



„This project has received funding from the Euratom research and training programme 2019-2020 under grant agreement No 945041”.

EXECUTIVE SUMMARY

The GFR Summer School event was organized by Research Centre Rez within SafeG project WP5. The event was focused on students and young professionals through technical lectures given by SafeG experts and technical tours. This deliverable describes the event's preparation process, program, and other outcomes. Presentations from the technical lectures are also attached to this document.

This document is prepared in compliance with the template provided by the Commission in Annex 1 of the Guidelines on Data Management in Horizon 2020.

CONTENT

1	EVENT DESCRIPTION.....	5
1.1	EVENT PREPARATION.....	5
1.2	PROGRAM DESCRIPTION.....	6
1.3	CONCLUSION AND FEEDBACKS	10
2	APPENDIX – LECTURES PRESENTATIONS	11
2.1	INTRODUCTION OF CVR	11
2.2	GEN IV TECHNOLOGIES AND ROADMAPS.....	11
2.3	GFR TECHNOLOGY OVERVIEW AND ALLEGRO CONCEPT	11
2.4	DEVELOPMENT OF KAIST MMR	11
2.5	ALLEGRO CORE DESIGN OPTIMIZATION	11
2.6	FAST REACTORS MODELLING.....	11
2.7	FUEL CYCLE OF FAST REACTORS AND PROLIFERATION RESISTANCE	11
2.8	SPECIFICS IN THERMAL-HYDRAULIC DESIGN OF GFR	11
2.9	GFR THERMAL-HYDRAULICS	11
2.10	HTR HISTORY, SAFETY AND COMPONENTS	11
2.11	S-ALLEGRO FACILITY	12
2.12	ADVANCED MANUFACTURING TECHNOLOGIES	12
2.13	RESEARCH ON MATERIALS FOR EXTREME CONDITIONS IN GEN IV.....	12
2.14	ENGINEERING ASPECTS OF GFR AND A1 ACCIDENTS	12
2.15	ADVANCED ENERGY TECHNOLOGIES WITH POTENTIAL OF USE IN GFR	12

1 EVENT DESCRIPTION

The GFR Summer School was an event organized within SafeG project WP5 at Centrum Výzkumu Řež (CVR), Czech Republic, in 2022. The four-day event was composed mainly of the technical program related to the GFR technology. The participants were students and young professionals from research or academic institutions involved in the SafeG project as well as those outside the project. This deliverable briefly describes the preparation and program of the event as well as the outcomes, feedback and recommendations for potential future events. Apart from this, the purpose of the deliverable is to collect and share presentations from the technical lectures, that are attached.

1.1 Event preparation

The event was originally scheduled for summer 2021. Due to the COVID restrictions in the Czech Republic as well as in CVR, the organization was postponed to 2022. The final dates were from 29th August to 1st September 2022. The preparation activities were launched in May 2022 by the promotion of the event and development of the technical program. To enhance the event promotion, a leaflet was prepared and shared via social media networks and relevant websites (Figure 1).

The leaflet features the SafeG logo and CVR logo at the top left. The main title is 'SafeG GFR Summer School'. Below the title, a paragraph describes the school's aim: 'The SafeG GFR Summer School is aimed at students and young professionals with an interest in not only GFR technology but also in other advanced nuclear reactors and innovative energy technologies. The program will be composed of lectures given by experts in the field, technical tours and hand-on exercises using the experimental facilities.' A 'Registration' box contains the following information: 'For register, please, fill out the registration form. The deadline for registration is 30th June 2022.' 'The technical program will be ensured by CVR and other invited lecturers. Technical lectures will be held in the site of ÚJV Řež a.s. (Hlavní 130, 250 68 Husinec-Řež, Czech Republic). There is no registration fee. Other costs (accommodation, travel, etc.) should be covered by the participant's institution.' The 'Preliminary program' section lists activities for three days: 29th August 2022 (13:00-14:00 Welcome, Event Introduction; 14:00-17:00 Technical Lectures - Introduction in the GFR technology, ALLEGRO, Alternative GFR designs); 30th August 2022 (09:00-12:00 Technical Lectures - Thermal-hydraulic, Neutronics, Nuclear Safety, History of GFR fuel development; 13:00-17:00 Technical Tour at the site of CVR - experimental facilities, experimental nuclear reactor); 31st August 2022 (08:00-16:00 Technical Tour to Pilsen - S-Allegro visit and hand-on exercises; 17:00-22:00 Social Event); and 1st September 2022 (09:00-12:00 Technical Lectures - Materials, Coolant Chemistry, technical visit of laboratories; 13:00-15:00 Technical Lectures - HTR Cross-cutting Activities, Advanced Energy Technologies; 15:00-16:00 Farewell). A 'Contact' box at the bottom right lists 'Tomas Melichar - Event coordinator' with the email 'tomas.melichar@cvrez.cz'.

Figure 1: GFR Summer School promotional leaflet

More than 60 candidates applied for participation through a registration form. The total capacity of the event including lecturers was set to 30. The capacity was limited mainly due to the technical tours. The final number of participants was 21 students and 8 senior participants or lecturers. The participants were selected based on the order of registration date and also aiming to diversify the students' institutions; the priority was given to candidates from the SafeG project partners institutions.

The students were from institutions in 6 countries (Czech Republic, Hungary, Poland, Slovakia, United Kingdom, USA). 66 % of the students were from the SafeG partners institutions. 62 % of the students had 1-3 years experience in nuclear R&D, 19 % had 3+ years experience and 19 % had no experience.

To refine the technical content, a survey of preferred topics was carried out through the registration form. The answers from all registered candidates are summarized in Figure 2. It is obvious that none of the offered topics received significantly higher interest, which supported the idea of having a wide variety of topics from the field of GFR and other advanced nuclear energy systems.

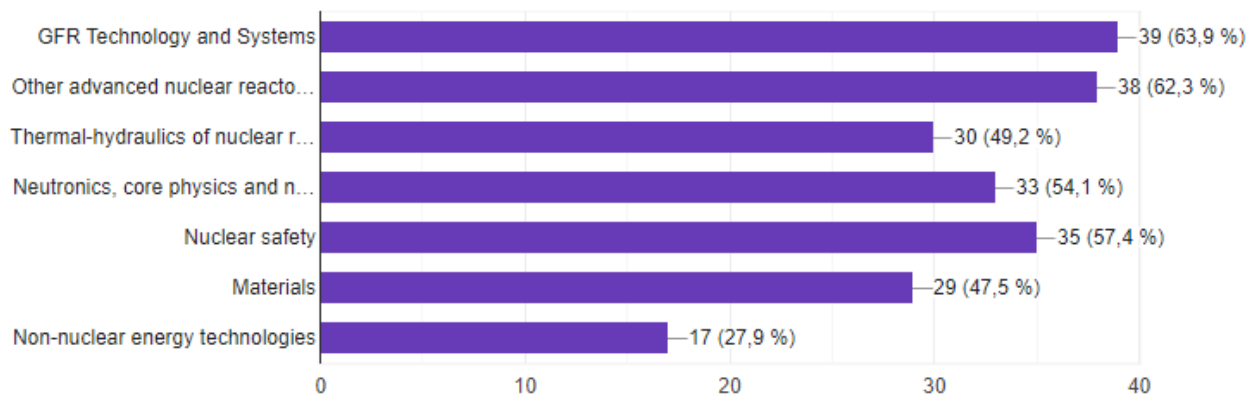

Figure 2: Survey on the topic preferred by registered candidates

The technical program was designed to cover the most important topics in GFR development. Additional constraints were the availability of experts from the SafeG project to contribute to the summer school, as well as the availability of various experimental facilities at the host institution. A detailed description of the technical program follows in Section 1.2.

1.2 Program description

This section briefly describes the program of the GFR Summer School. The content of lectures is presented in the attached presentation slides.

The program started on Monday 29th August by introductory welcome remarks by Tomas Melichar (CVR). The program was described as well as organization-related issues. The introduction of all participants took place.

Introduction of CVR was then given by **Jana Kalivodova** from CVR. The host institution was introduced including its R&D priorities, the most important projects and research infrastructure (see Appendix 2.1).

Generation IV technologies and Roadmaps lecture with a focus on the fast reactors concepts was given by **Eugene Shwageraus** from UCAM. The main aspects of the fast reactors were presented and the rationale for fast reactors was discussed (see Appendix 2.2).

GFR Technology Overview and ALLEGRO Concept was introduced by **Petr Vácha** from UJV. A general overview with a focus on the GFR history and current R&D activities was given. ALLEGRO and HeFASTo concepts including the main components were also presented (see Appendix 2.3).

Development of KAIST-MMR was presented by Professor **Jeong Ik Lee** from KAIST. The last lecture of Monday's program was focused on the description of alternative supercritical CO₂-based GFR concepts (MIT-GFR 2400 MW_{th} and especially KAIST-MMR 50 MW_{th} concept). Current

status, challenges and R&D activities related to the KAIST-MMR were presented. The lecture was given online (see Appendix 2.4).



Tuesday's program was also composed of technical lectures. Due to technical issues, the visits to experimental facilities of CVR were moved to Thursday 1st September.

Fast Reactor Modelling and Core Design lecture was given by **Eugene Shwageraus** from UCAM. The physics of fast reactors was introduced, followed by an overview on the simulations strategies and multi-physics effects. Terms such as sensitivity, uncertainty and validation were also discussed (see Appendix 2.5).

ALLEGRO core design optimization was given by **Petra Pónya** from EK. An introduction of the ALLEGRO concept from the core point of view, core design optimization influencing parameters and methods were presented as well as the results of work done within SafeG project (see Appendix 2.6).

A lecture on the **Fuel Cycle of Fast Reactors and Proliferation Resistance** was given by **Jan Uhlíř** from CVR. The fast reactors issues connected with the closed fuel cycle were introduced including an overview on the reprocessing technologies. The non-proliferation study of ALLEGRO concept as an activity of the SafeG project was also presented (see Appendix 2.7).

Specifics in Thermal-hydraulic Design of GFRs topic was presented by **Jan Pokorný** from UJV. The lecture included a general overview of the gas coolants specifics with a particular focus on decay heat removal and natural convection. Conceptual designs of some key components of the decay heat removal system for ALLEGRO were also presented (see Appendix 2.8).

The second thermal-hydraulics related lecture on **GFR Thermal-hydraulics** was given by **Gusztáv Mayer** from EK. The lecture was dedicated to the ALLEGRO concepts and their thermal-hydraulics

specifics. Selected challenges such as duct breaks or nitrogen injections and modelling approaches were presented (see Appendix 2.9).

The last presentation from Tuesday's program (moved from Thursday) was related to the **HTR History, Safety and Components** and was given by **Gerd Brinkmann** from BriVaTech. The history of the HTR technology was presented. A major part of the presentation was focused on the HTR systems including the auxiliary ones and components description supplemented by experience with the components R&D and manufacturing (see Appendix 2.10).



Wednesday's program was composed of a tour to the second site of CVR in Pilsen. A large-scale experimental facility **S-Allegro** which is the largest experimental infrastructure utilized within the ALLEGRO development was visited. The 1 MW_{th} facility is designed as a scale-down of the GFR concept ALLEGRO. The main purpose is a simulation of systemic thermal-hydraulic behaviour of the system at various operational regimes including the accidental ones. As the facility was in the design optimization phase, the visitors had an opportunity to see some internal parts of the facility. A lecture introducing the design of the facility, its commissioning, the first experiments and the experimental possibilities was also given by Tomas Melichar from CVR (see Appendix 2.11). A supplementary technical visit to **HELCZA** facility was also organized. The facility is involved in activities related to testing of components at high heat flux conditions, especially within the fusion R&D. The social event at the Pilsner Urquell brewery with subsequent dinner at the brewery's restaurant provided excellent networking opportunity for the summer school participants and organisers.



The program on the last day of the event combined both lectures and technical tours. The first lecture on the topic **Research on Materials for Extreme Conditions in GEN IV** with a focus on the competencies and infrastructure of NCBJ in the field of materials research was given by **Jaroslav Jasinski** from NCBJ (see Appendix 2.12).

Advanced manufacturing technologies and their potential role in high-temperature systems development was presented by **Udi Woy** from UFSD. Some activities and goals of the SafeG project WP2 were also presented (see Appendix 2.13).

The last lecture given by **Václav Dostál** from CTU was composed of two parts. The first part was focused on **Engineering Aspects of Gas Cooled Reactor Technology**, summarising the gas-cooled reactor types, characteristics and design options. The second part was focused on the **A-1 nuclear power plant** and detailed description, phenomenology, consequences and lessons from the A-1 accidents (see Appendix 2.14).

Due to limited time, a lecture on the topic **Advanced Energy Technologies with Potential Use in GFR** by **Tomas Melichar** was cancelled, but the presentation is available in Appendix 2.15. The presentation described selected energy technologies, that can be potentially coupled with the GFR of other high-temperature reactor systems to improve their utilisation factor or efficiency. Specifically, supercritical CO₂ based energy conversion cycles, high-temperature energy storage options and high-temperature electrolysis for hydrogen production are introduced.

During Thursday's technical part, the group visited three facilities with various research infrastructure. The **LVR-15 reactor** is a research reactor with 10 MWt power is being used for various applications including radioisotopes production and materials research. The tour was composed of a visit to the reactor hall, control room and hot cells facility. The second visit was to **experimental hall 213** of CVR. There, the participants were introduced to various experimental facilities including the sCO₂ loop, high-temperature helium loop HTHL for materials research in the GFR or HTR-related environment, liquid metals laboratory and hydrogen technology laboratory. The last visit was to **experimental hall 271**, where a large-scale facility LOCA is located. This facility is used for qualification tests of PWR components at LOCA-relevant conditions. Several lab-scale facilities employed in various research fields were also presented.

1.3 Conclusion and feedbacks

The event was concluded on Thursday afternoon. Each participant was awarded a certificate of participation. A plenary feedback session also took place. Positive feedback related to both organisation and the technical program was received from the participants. The suggestions for potential future events were related to more interactive learning such as the implementation of more panel sessions and discussions or additional common social activities. Including additional non-engineering topics such as regulation, sustainability or environmental science was also suggested. One of the conclusions from the organising committee is that the technical program was relatively tight with limited space for other additional activities.

It can be concluded that the event organisation and execution was high quality and without encountering any major problems. A great advantage was the participation of several senior experts from the SafeG project and the ALLEGRO community, that were willing to discuss various topics with the students during the program. The main expectations, which were the experience sharing, networking and the SafeG project results dissemination, were met and the lessons learned can be used for organisation of other events within the SafeG project. The interest in the event was overwhelming and the number of participants exceeded expectations even at the upper bound of our Key Performance Indicator. The highest KPI for this event defined in the project proposal has been achieved (>25 participants is considered "excellent").



2 APPENDIX – LECTURES PRESENTATIONS

2.1 Introduction of CVR

Please see attached pdf document “1_CVR_Introduction”

2.2 Gen IV Technologies and Roadmaps

Please see attached pdf document “2_GENIV_Technologies_and_Roadmaps”

2.3 GFR Technology Overview and ALLEGRO concept

Please see attached pdf document “3_GFR_Technology_Overview_and_Allegro_Concept”

2.4 Development of KAIST MMR

Please see attached pdf document “4_Development_of_KAIST_MMR”

2.5 ALLEGRO Core Design Optimization

Please see attached pdf document “5_ALLEGRO_Core_Design_Optimization”

2.6 Fast Reactors Modelling

Please see attached pdf document “6_Fast_Reactors-Modelling”

2.7 Fuel Cycle of Fast Reactors and Proliferation Resistance

Please see attached pdf document “7_Fuel_Cycle_of_FR_and_Proliferation_Resistance”

2.8 Specifics in Thermal-Hydraulic design of GFR

Please see attached pdf document “8_Specifics_in_Thermal-hydraulic_Design_of_GFRs”

2.9 GFR Thermal-Hydraulics

Please see attached pdf document “9_GFR_Thermal_Hydraulics”

2.10 HTR History, Safety and Components

Please see attached pdf document “10_HTR_History_Safety_Components”

2.11 S-Allegro facility

Please see attached pdf document “11_S_Allegro”

2.12 Advanced Manufacturing Technologies

Please see attached pdf document “12_Advanced_Manufacturing_Technologies”

2.13 Research on Materials for Extreme Conditions in GEN IV

Please see attached pdf document “13_Research_on_Materials_for_Extreme_Conditions”

2.14 Engineering Aspects of GFR and A1 Accidents

Please see attached pdf document “14_Engineering_Aspects_of_GFR_and_A1_Accidents”

2.15 Advanced Energy Technologies with Potential of Use in GFR

Please see attached pdf document “15_Advanced_Energy_Technologies”

What is Centrum výzkumu Řež?

Jana Kalivodová

GFR Summer School; August 29th – September 1st; Řež; Czech Republic

Centrum výzkumu Řež s.r.o. (CVR) / Research Centre Řež



- Research, development and innovation organization developing ideas, technologies and solutions in the sustainable energy production including nuclear power, innovative next-generation energy systems and energy storage technologies
- **2002** year of CVR's establishment
- **421** number of employees
- **1932** number of registered scientific results
- **129** number of projects

History of Nuclear Research in Řež

1950

1955
Formation of the Institute of the Nuclear Physics

1957
the research reactor LVR-15 was launched

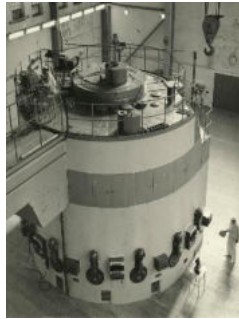

1970

1972
Reorganization and formation of the Nuclear Research Institute

1983
the research reactor LR-0 was launched

1990



October 9th, 2002
CVR was founded



2007 Entering consortium Jules Horowitz Reactor

2010

SUSEN

2012
Start of the project SUSEN

CVŘ research activities

- Services and solutions to support the safe and sustainable use of nuclear energy
- Research and development of the advanced nuclear reactors including GIV systems, nuclear fusion technologies and Small Modular Reactors
- Material research for energy & extending the lifetime of power plants
- Nuclear waste management and disposal
- Nuclear safety
- Low carbon energy technologies, energy storage, hydrogen production
- Training & EDU; partner in many European and international research and innovation communities

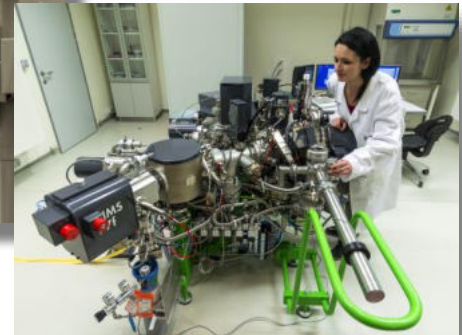
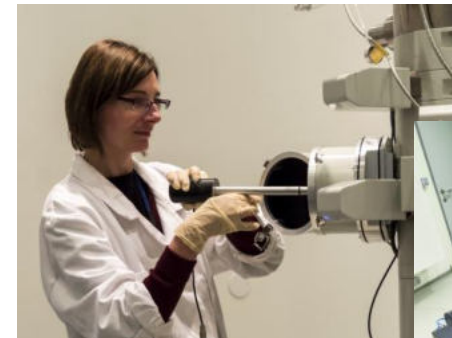
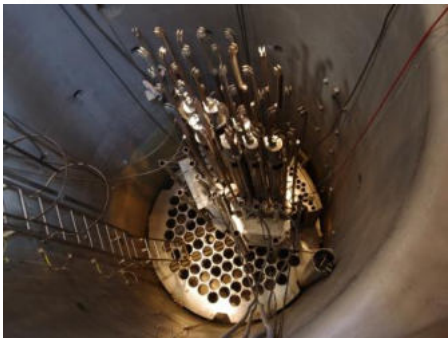

Czech International Centre of Research Reactors (CICRR)

Research reactors LVR-15 and LR0; the experimental loops (SCWL, HTHL, S-Allegro, sCO₂, HLML, MSL); Hot Cell laboratory; Microscopy; Mechanical stability testing labs; Radiochemistry laboratory; Elemental and isotopic analyses; Laboratory of non-destructive testing; Computational safety analyses; Laboratory of neutron generators; Gama radiation laboratory; HELCZA; Design & manufacturing department



Research Reactor LVR-15

- Testing of material degradation of reactor primary circuit and internals carried out in experimental in-pile loops - coolant interaction
- Qualification of components in radiation fields (neutrons/gamma)
- Neutron scattering experiments and activation analysis for nuclear analytical investigations and for fundamental nuclear physics studies
- Manufacture of semiconductors by neutron transmutation doping of silicon for the electrical industry
- Production and development of radiopharmaceuticals, Tc generators

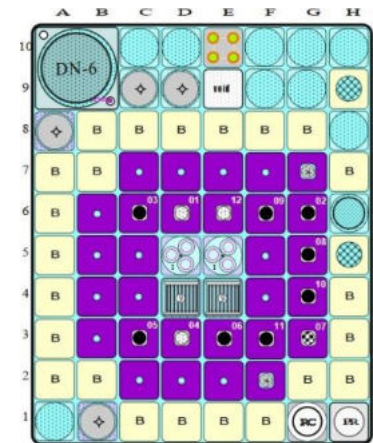
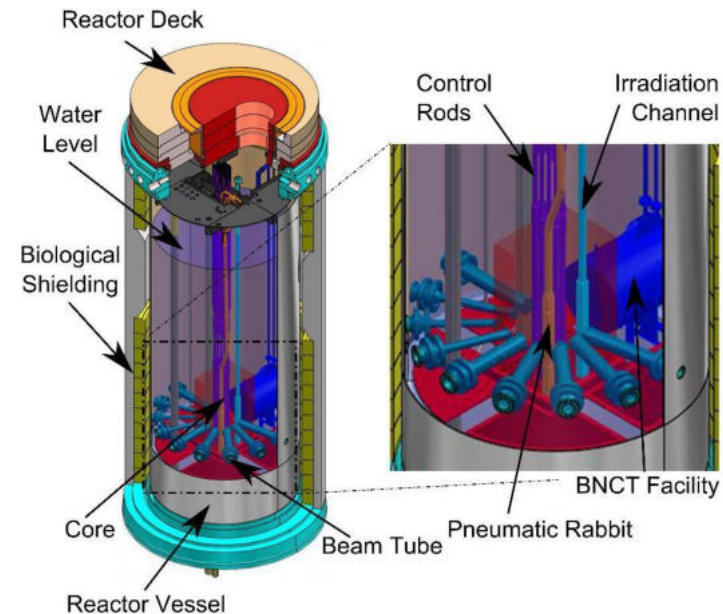

Typical core layouts with in-fuel irradiation rig in position

- Maximal thermal power: 10 MWth;
- Maximal available thermal neutron flux: $2 \times 10^{14} \text{ n} \cdot \text{cm}^{-2} \cdot \text{s}^{-1}$;
- Maximal available fast neutron ($> 1 \text{ MeV}$) flux: $6 \times 10^{13} \text{ n} \cdot \text{cm}^{-2} \cdot \text{s}^{-1}$;
- Pressure: atmospheric;
- Coolant Temperature: max. 56 °C.

Experimental Reactor LR-0

- The light water zero power reactor, with flexible core arrangements
- Experiments with various insertion zone types (graphite, fluoride salts)
- Determination of neutron-physical characteristics of various types of reactor lattices, kinetics experiments
- Experimental verification of criticality and subcriticality in relation to zone parameters
- Verification of codes



Experimental Loops

Structural material degradation, corrosion, mechanical properties, thermal-hydraulic, and further research under operational conditions of various reactor concepts (LWR & GIV)

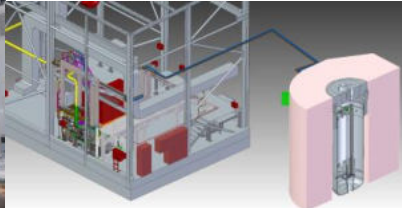

- **LWR loops** – LWR reactors conditions (320 °C, 17 MPa)
- **SCWR loop** – water of supercritical parameters (550 °C, 25 MPa)
- **HTHL loops** – high-temperature helium up to 850 °C
- **sCO₂ loop** – supercritical carbon dioxide – heat transfer through sCO₂
- **S-ALLEGRO loop** - Verification of the basic safety features and system behaviour of the GFR concept - ALLEGRO
- **Metal liquid loops** – Pb, PbBi
- **FLiBe loop** – LiF-BeF₂ and nickel-based alloy (< 760 °C)

Hot Cells Laboratory



- Developed, designed, manufactured and assembled by Research Centre Řež
- 8 γ hot cells, 2 α hot cells, semi hot cell and dry pool
- Purpose: study of nuclear reactors materials degradation and their mechanical properties

Microstructural and Microchemical Labs



Light Optical Microscope (LOM)
Scanning Electron Microscope (SEM)
Transmission Electron Microscope (TEM)
Secondary Ion Mass Spectroscopy (SIMS)
Nanoindenter

- Microstructural and microchemical analysis of various types of metal and nonmetallic materials
- Study of radiation damage of structural materials for nuclear reactors
- Development of new methods of the detection of very low activity in very small samples

Severe Accidents Laboratory

LOCA (Loss of Coolant Accident) device
High voltage testing room
Gamma irradiation device

- Qualifications of components for nuclear power plants
- Developing new procedures of thermal and radiation resistance verification and structural materials behaviour under the extreme conditions of severe accidents



Cold Crucible Laboratory

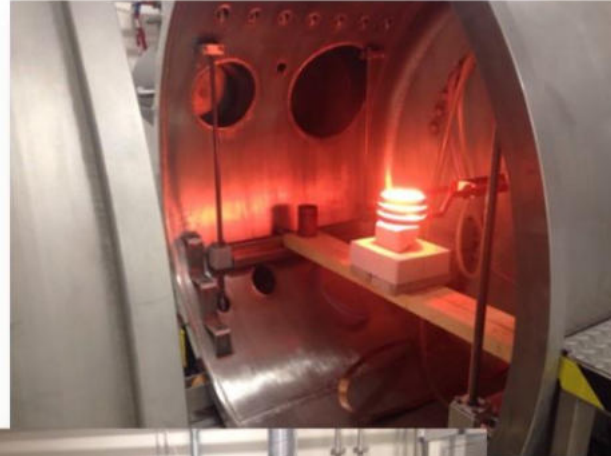
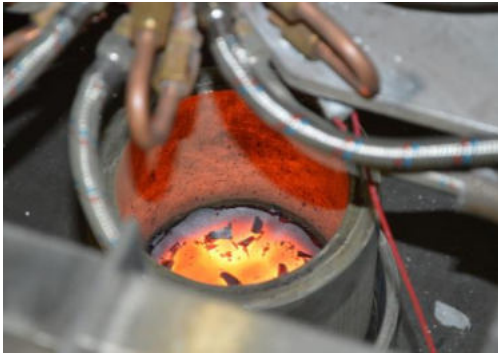

- High-frequency induction melting in a cold crucible
- Thermal treatment of materials which are very difficult to treat by standard procedures
- Advanced studies of corium behaviour during severe accidents
- Crystal growth
- Phase diagram research
- Glass melting

HELICZA - High Energy Load Czech Assembly

<https://www.helcza.com/>



- Extensive experimental device built for the purpose of cyclic thermal testing of future generation fusion high-heat-flux loading of components (ITER FW modules, divertor inner vertical targets)
- Material research and study of physical phenomena in conditions of high heat flux generated by electron beam 20kHz

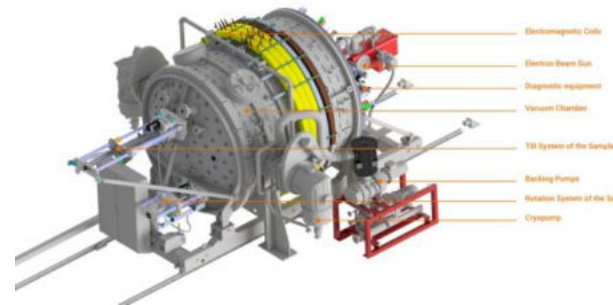

NDE and Material Testing Laboratories

- Current generation of nuclear power plants lifetime extension and aging management support
- Development of new diagnostic methods (NDE) and manipulators for power plants
- Material studies and testing for current and GEN IV reactors
- Fuel assemblies inspection programme

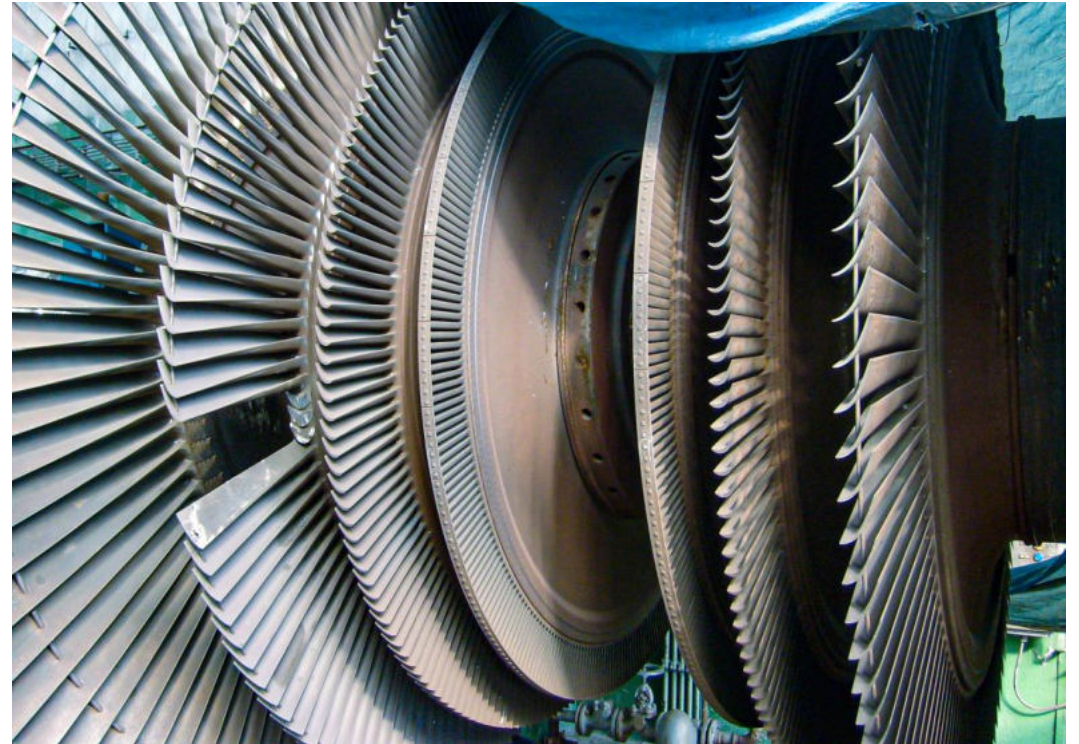

Fuel Reprocessing and Separation Methods, Radioactive Waste Treatment

- Advanced spent fuel reprocessing methods developing – lanthanoids and actinoids separation by fluoride volatility method
- Developing and verification of on-line reprocessing technology for Molten Salt Reactors (MSR)
- Corrosion experiments with molten fluorides (up to 1,000 °C)
- MSO – Molten Salt Oxidation technology
oxidation of radioactive waste in the molten salts (Na_2CO_3)
- ETL – Experimental Technology Line
development of methods for liquid radioactive waste minimization



Jules Horowitz Reactor



Scope of CVŘ supply of Hot Cells

Detailed design including the necessary calculations – biological (shielding), seismic, static, and engineering – and other studies

Manufacturing of embedded steel structure, shielding doors, docking port, stainless steel liner, special prototype lifting devices, crossings

Mounting on site

Factory and site testing

- International project
- Construction of a new, highly powerful nuclear reactor for research in the material field and nuclear fuel with the capacity of 100 MW

Energy Well

Small modular reactor concept (FHR) based on TRISO fuel and cooled by fluoride salt (700 °C, atmospheric pressure)

- long operation without refuelling, 20 MW_t for 7 years
- compact design – transportable in two ship containers
- very high level of passive and inherent safety for remote areas or areas with poor infrastructure

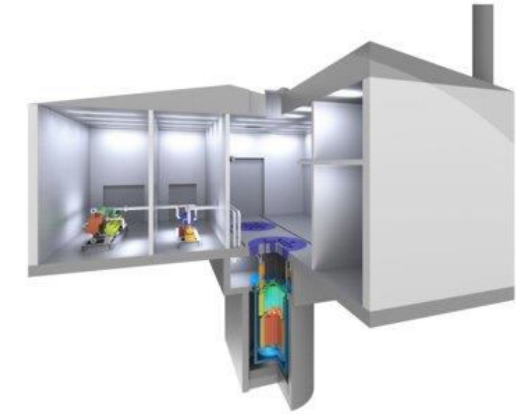

<https://www.energywell.cz/>

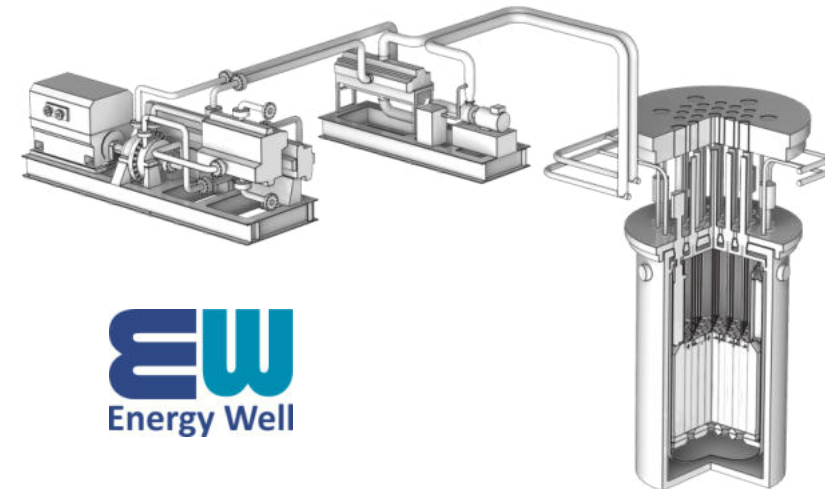

EW
Energy Well

Training & EDU activities

- Access to research infrastructure and professional support for student theses (bachelor, master and doctoral programs)

- OPEN ACCESS opportunity

https://epra2.cz/e2_ext.php?action=openaccess

- Conferences and workshops



- Journal: Jaderná Energie

<https://jadernaenergie.online/en/home/>

je

- Training and summer schools



CVR international projects & partners

FOREVER	Security of supply of nuclear fuel for research reactors
MEACTORS	Safety and reliability of Generation II and III reactors
EURAD	Safe start of operation of the world's first geological disposal facilities
SANDA	Advanced simulation models and more accurate nuclear data
ARIEL	Supply of suitable personnel for the strengthening of the nuclear safety culture
SAMOSAFER	New simulation tools for Generation IV reactors
sCO2-4-NPP	SCO2 technology for nuclear power plants
JHOP2040	Roadmap for 15 years from the start of the 1st irradiation campaign at JHR
ACES	Safe long term operation of the existing nuclear fleet
ECC-SMART	Development of SCWR small modular reactor
PREDIS	Pre-disposal of radioactive waste
PATRICIA	Reducing the volumes and hazard of high-level long-lived radioactive waste
TOURR	Radioisotopes production needs across Europe
ORIENT-NM	Fission reactor materials
SafeG	Safety improvements of Generation IV systems
EUROfusion	European Fusion Roadmap
COMPASsCO 2	New materials and combined components for sCO2
DELISA	Long term operation of existing nuclear power plants
INNUMAT	Innovative Structural Materials for Fission and Fusion
NPHyCo	Facilitating cross-sectoral synergies to the hydrogen industry
MIMOSA	MOX fuel recycling
ENEN++	Enhancing nuclear competences, education and training programs

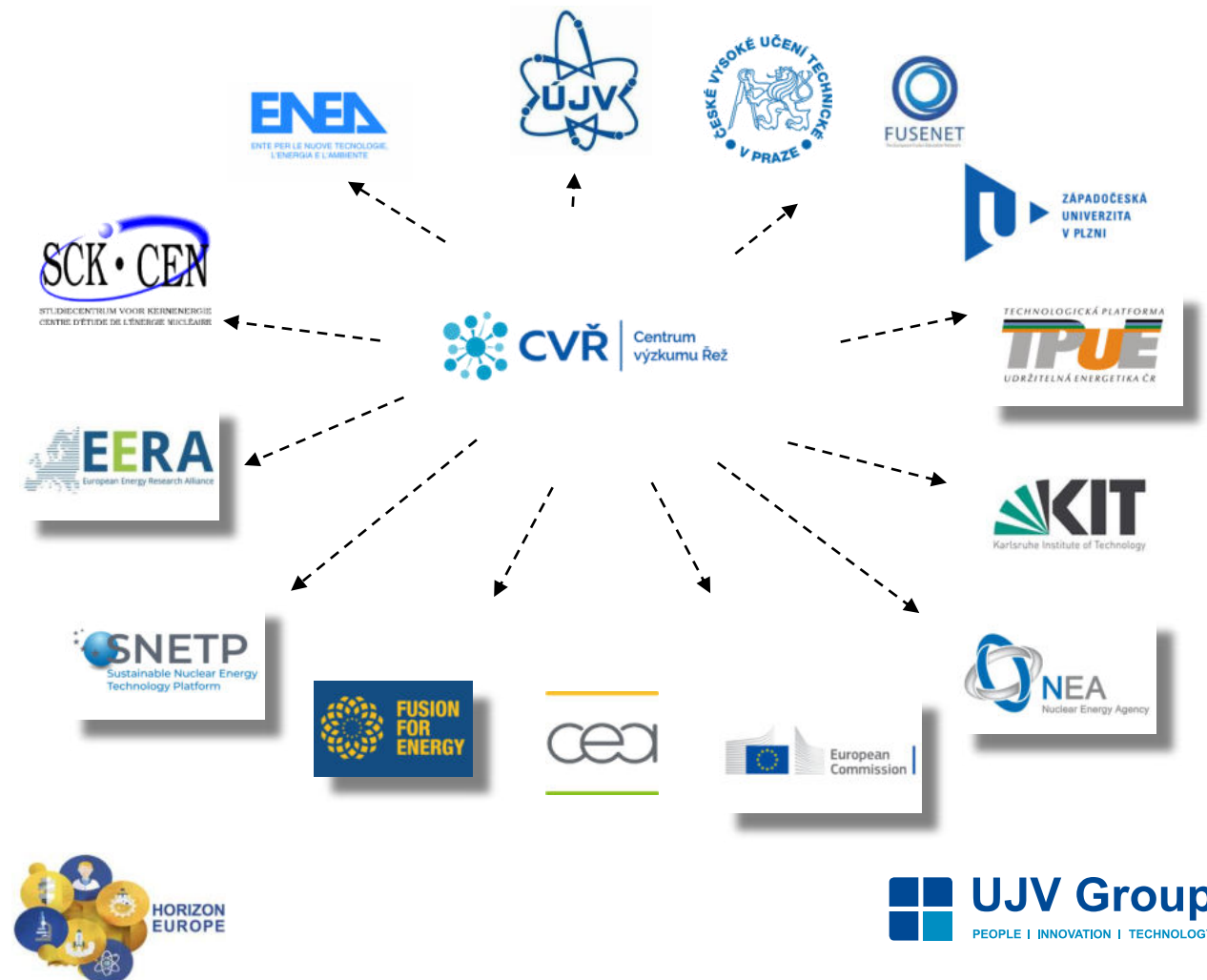

Thank you for your attention

Centrum výzkumu Řež s.r.o.
Hlavní 130, Řež
250 68 Husinec

www.cvrez.cz/en

Gen IV Technologies and Roadmaps

Eugene Shwageraus

University of Cambridge

Generation IV International Forum (2002)

- Established a set of criteria for selection
 - Sustainability, Waste, Safety, Economics, Non-proliferation
- Selected 6 reactor concepts for communal development
 - SFR, LFR, GFR, MSR, SCWR, VHTR

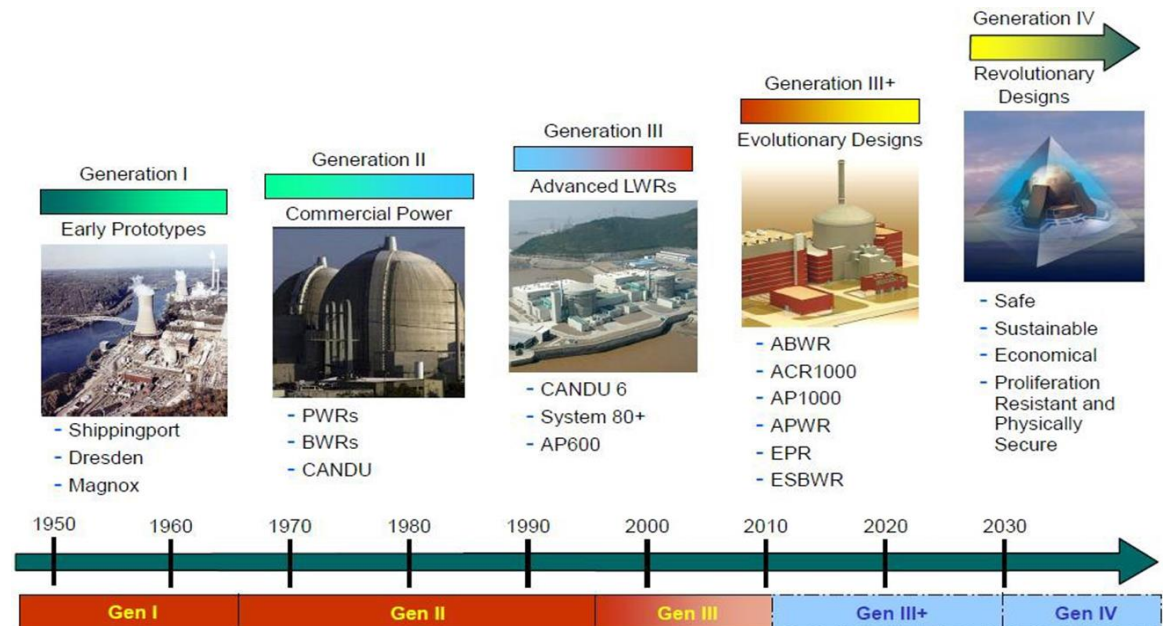
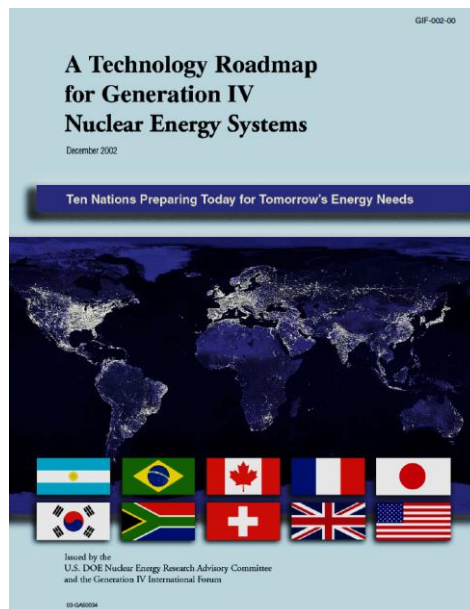

Fuel cycle

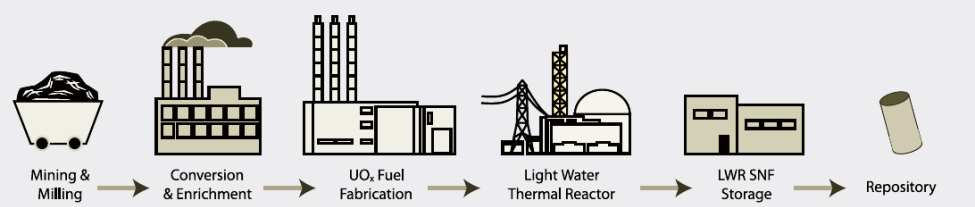

Open

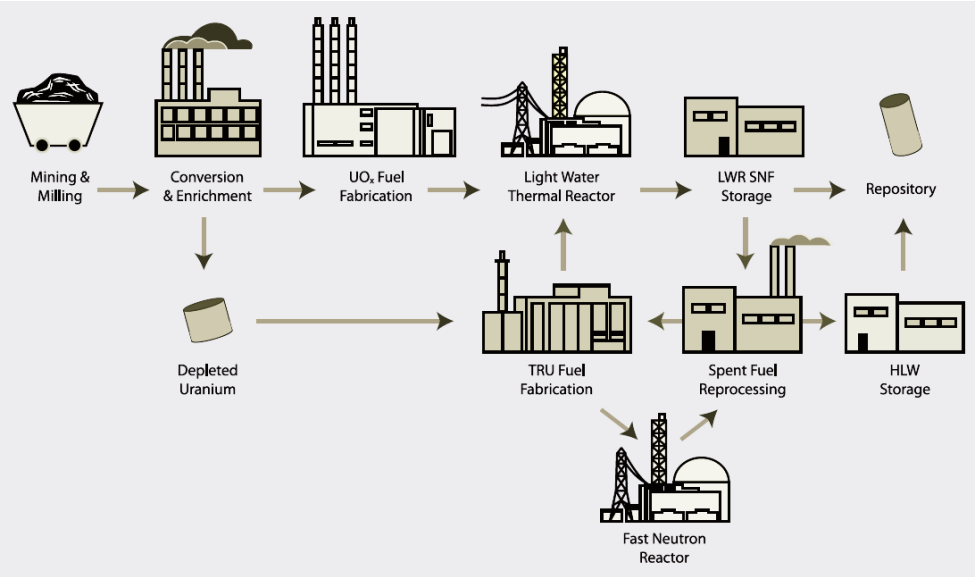

Closed

Incentives for closed fuel cycle



➤ Source of Energy

- Residual fissile and fertile material can be recycled into new fuel
- Potential for “limitless” fuel through breeding

➤ Energy Security

- Uranium supply is finite and availability varies by location

➤ Waste Management

- Superior storage and/or disposal forms relative to SNF
- Separate transuranics (Pu, Am, Np) for transmutation

➤ Non-proliferation

- Limits use of enrichment facilities
- Avoid sending fissile materials to repository

Focus on fast systems

- Fast spectrum reactors are generally preferable for several Gen-IV goals
- Can operate in a closed fuel cycle
 - Generate fissile material faster than consume (breeders)
 - Indefinitely recycle all environmentally important nuclides
 - Indefinitely recycle weapons usable nuclides
- 5 out of 6 Gen-IV concepts are (or could be) fast reactors

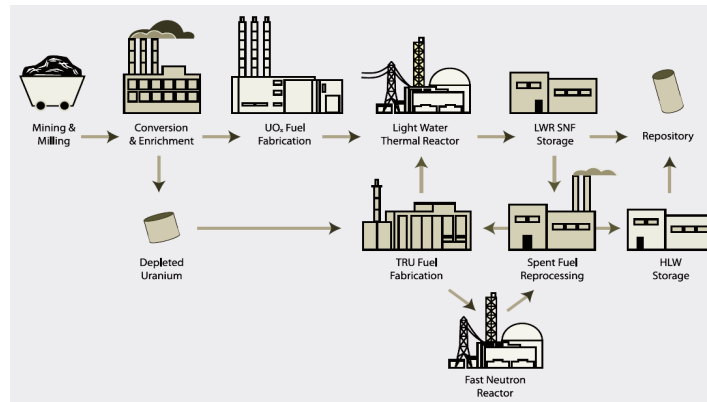

Gen IV International Forum Objectives



➤ Sustainability:

- Generate energy sustainably and promote long-term availability of nuclear fuel
- Assumption: Natural Uranium supply is limited and it needs to be conserved

➤ Waste management:

- Minimise and manage nuclear waste, reduce the long-term stewardship burden
- Assumption: Long term storage of spent fuel is prohibitively expensive
- Assumption: Long term storage of spent fuel is environmentally dangerous
- Assumption: Long term storage of spent fuel is socially irresponsible

➤ Economics:

- Clear life-cycle cost advantage over current nuclear other energy sources
- Level of financial risk comparable to other energy projects
- Assumption: Reactors can be designed to be substantially cheaper than LWRs

Gen IV International Forum Objectives



➤ Safety and Reliability:

- Excel in safety (intrinsic and/or passive features) and reliability
- Very low likelihood and degree of reactor core damage
- Eliminate the need for offsite emergency response
- Assumption: Reactors can be designed to be substantially safer than LWRs
- Assumption: Reactors should be designed to be substantially safer than LWRs

➤ Proliferation Resistance:

- Unattractive route for diversion of weapons-usable materials
- Increased physical protection against acts of terrorism.
- Assumption: Proliferation risks can be minimised by closing the fuel cycle and transition to advanced (non-LWR) reactors

Uranium Resources

Resource Category	Tons Uranium
RAR (<\$80/kg U)	1,555,000
EAR-I (<\$80/kg U)	891,000
RAR (\$80 to \$130/kg U)	678,000
EAR-I (\$80 to \$130/kg U)	425,000

		Known Resources		Unknown Resources	
RECOVERABLE AT COSTS	\$130 to \$260 / kg U	REASONABLY ASSURED RESOURCES (RAR)	ESTIMATED ADDITIONAL RESOURCES I (EAR-I)	ESTIMATED ADDITIONAL RESOURCES II (EAR-II)	SPECULATIVE RESOURCES (SR)
	\$80 - \$130 / kg U	REASONABLY ASSURED RESOURCES	ESTIMATED ADDITIONAL RESOURCES I	ESTIMATED ADDITIONAL RESOURCES II	SPECULATIVE RESOURCES
	up to \$80 / kg U	REASONABLY ASSURED RESOURCES	ESTIMATED ADDITIONAL RESOURCES I	ESTIMATED ADDITIONAL RESOURCES II	

DECREASING CONFIDENCE IN ESTIMATES →

Distribution of Uranium in the Earth

- Elasticity of supply

$$S = \frac{\% \text{ increase in reserves}}{\% \text{ decrease in ore grade}}$$

- Currently ~2
- Suggests increase in U price with time
- **Exploration, improved extraction and more efficient utilisation** effects counteract the scarcity effect
- The latter is more significant so far
- True for 34 minerals over the past 100y

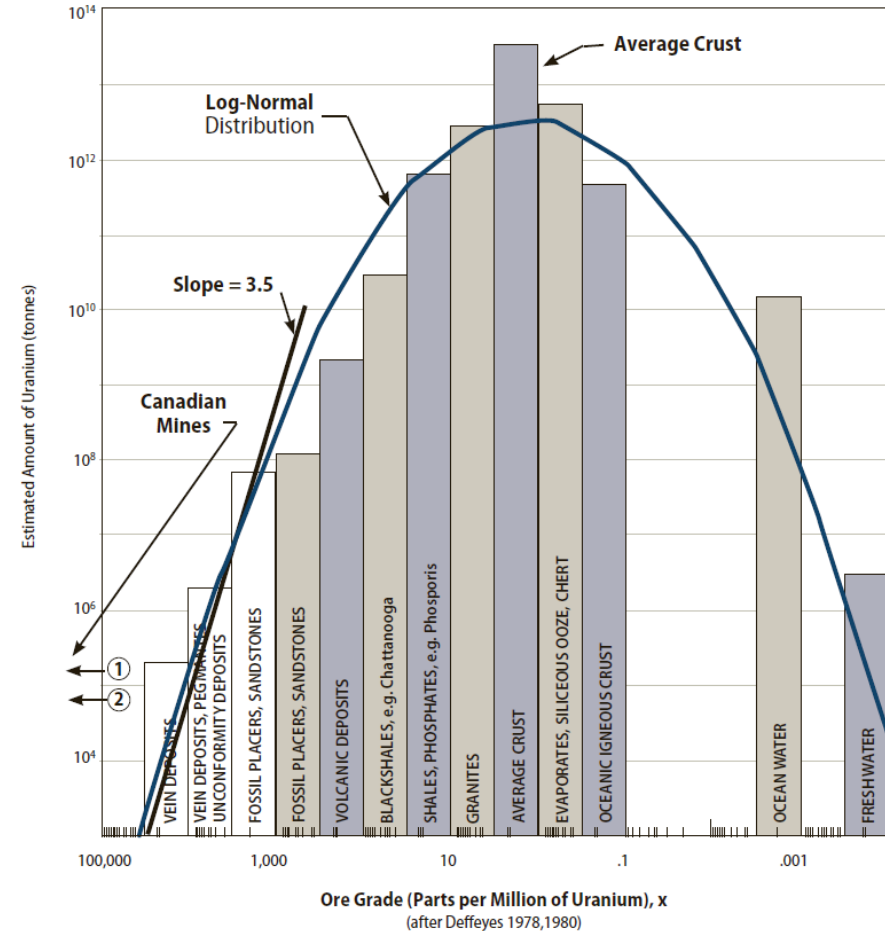

Matthews and Driscoll, (2010)

A Probabilistic Projection of Longterm Uranium Resource Costs

Uranium from seawater

- Affects competitiveness of recycling and fast breeder reactors
- Cost may soon be competitive with traditional sources
 - Even if more expensive, cost of nuclear only weakly dependent on fuel costs
- More uranium is leached from crust to maintain equilibrium (effectively infinite)

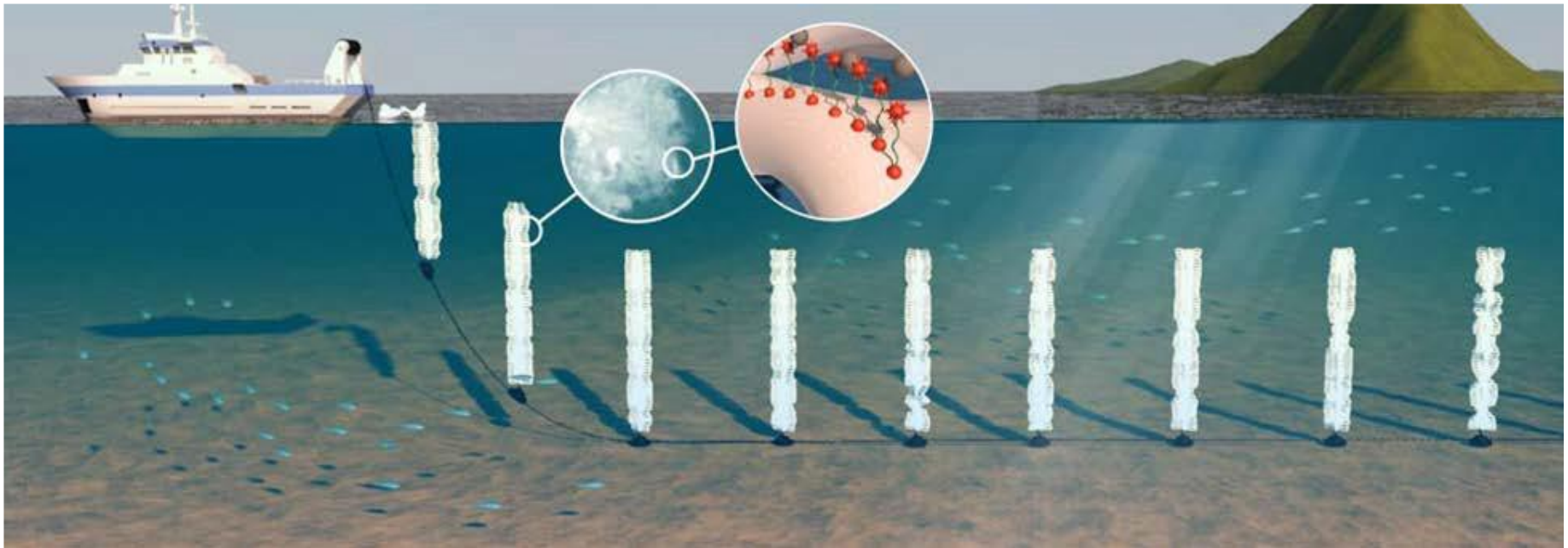

Rationale for Fast Reactors

- Breeding and transmutation require abundant neutrons
- Neutrons are born in fission, lost through absorptions and leakage

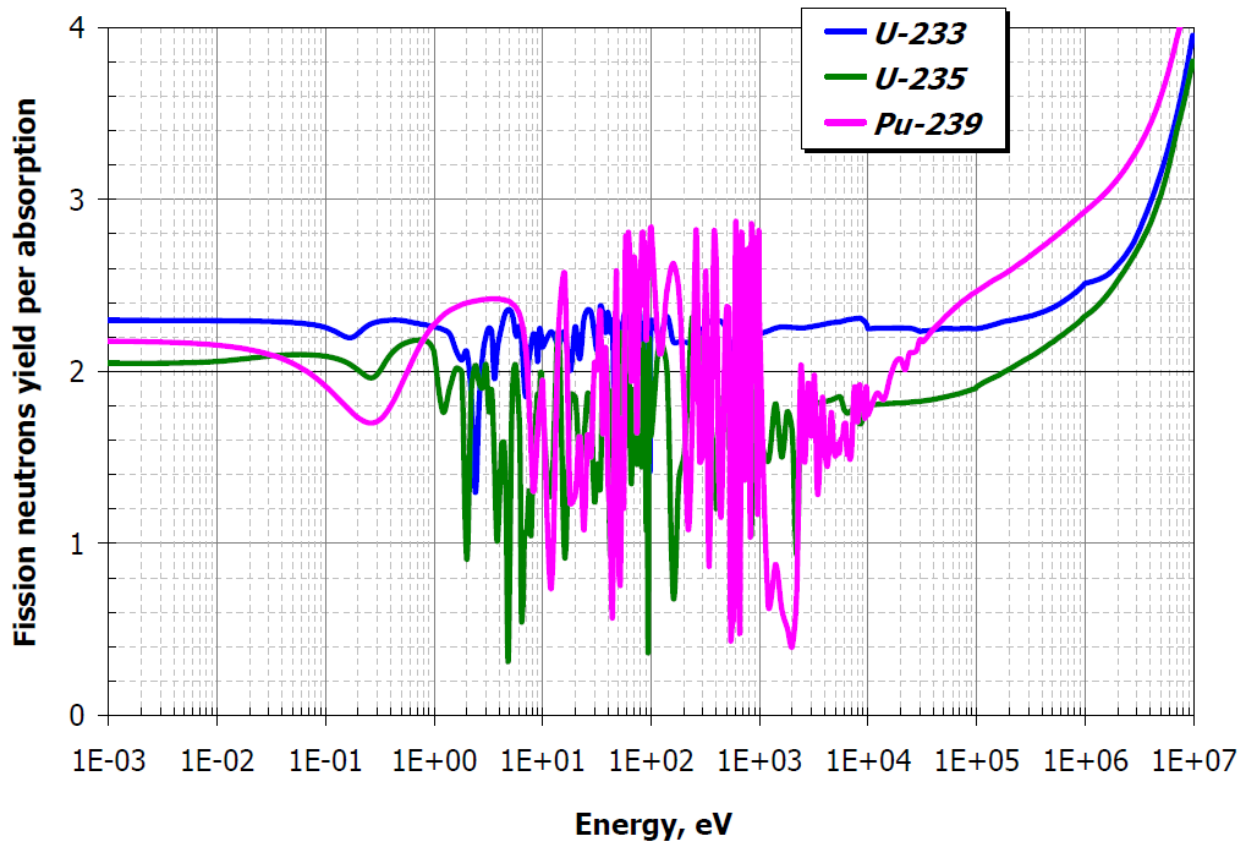

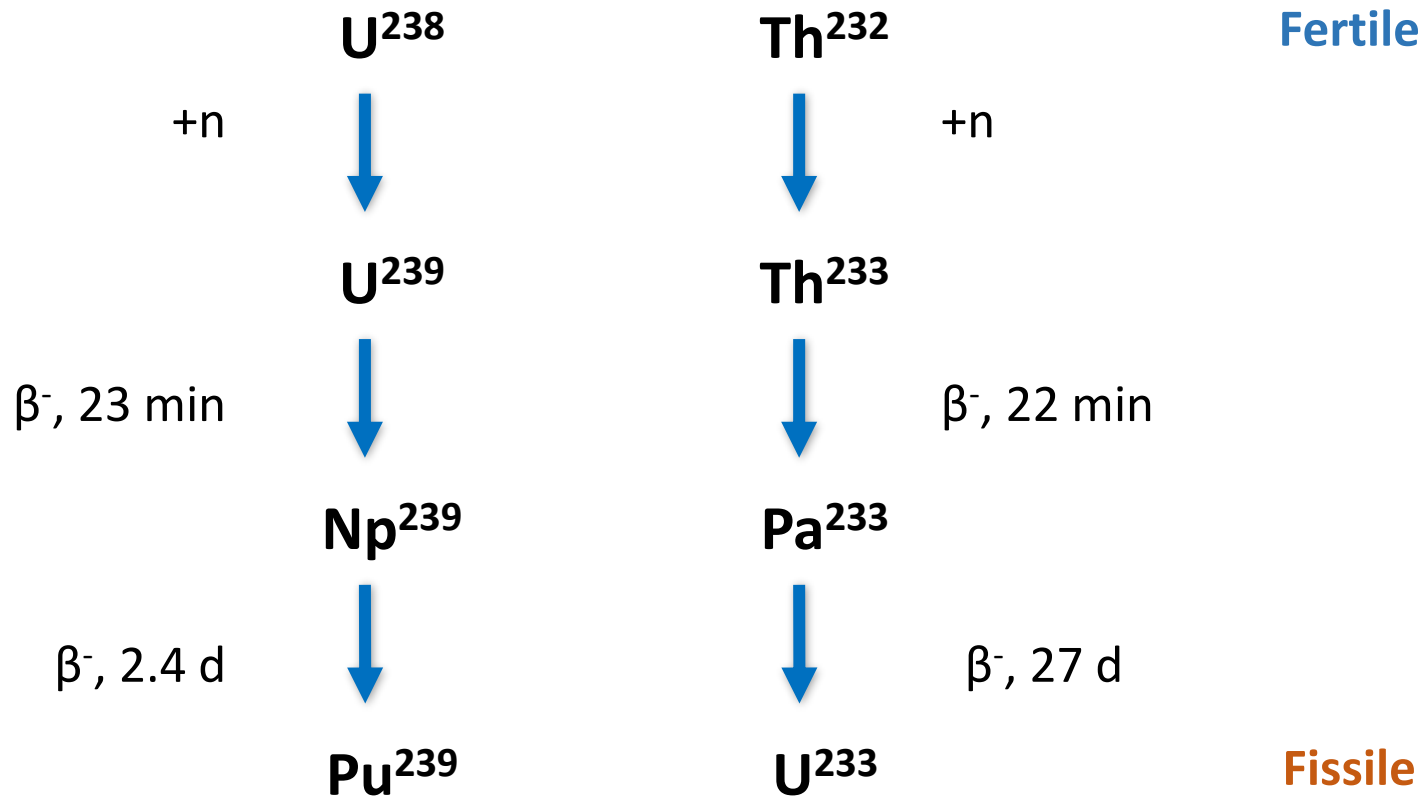

Breeder Reactors Terminology

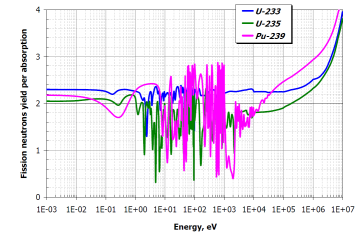

➤ Conversion Ratio: $C = \frac{\text{Rate of fissile nuclides production}}{\text{Rate of fissile nuclides disappearance}}$

➤ If $C > 1$, it is called Breeding Ratio: BR

➤ Breeding Gain: $G = BR - 1$

➤ Capture to Fission Ratio: $\alpha = \frac{\sigma_c}{\sigma_f}$

➤ Number of neutrons released per fission: $\bar{\nu}$

➤ Neutrons produced per neutrons absorbed: η

Breeder Reactors Terminology

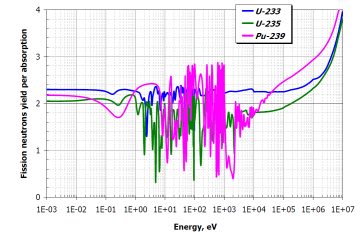

$$\eta = \frac{\text{neutron production}}{\text{neutron loss}} = \frac{\bar{\nu} \sigma_f}{\sigma_a} = \frac{\bar{\nu} \sigma_f}{\sigma_f + \sigma_c} = \frac{\bar{\nu}}{1 + \frac{\sigma_c}{\sigma_f}} = \frac{\bar{\nu}}{1 + \alpha}$$

- One neutron is needed to compensate for the loss to the fissile atom

⇒ Maximum possible BR:

$$BR_{max} = \eta - 1$$

- Neutrons loss to leakage and parasitic absorption:

L

- Thus, necessary condition for critical breeder reactor:

$$\eta - 1 - L > 1$$

or

$$\eta - L > 2$$

- Breeding Ratio accounting for neutron losses:

$$BR = \eta - 1 - L$$

Reactor Doubling Time

- Time to produce enough fissile material to fuel a new, identical reactor
- Initial fissile inventory: m_0
- Fissile material gain per year: \dot{m}_g

$$T_D = m_0 / \dot{m}_g = \frac{2.7 \times m_0}{P \times \bar{G} \times (1 + \alpha)}$$

- To shorten the Doubling Time:
 - High Breeding Gain
 - Small capture to fission ratio
 - Small specific fissile inventory m_0/P (or high specific power W/kg)

Rationale for Fast Reactors

Convert long-lived actinides into short-lived FP

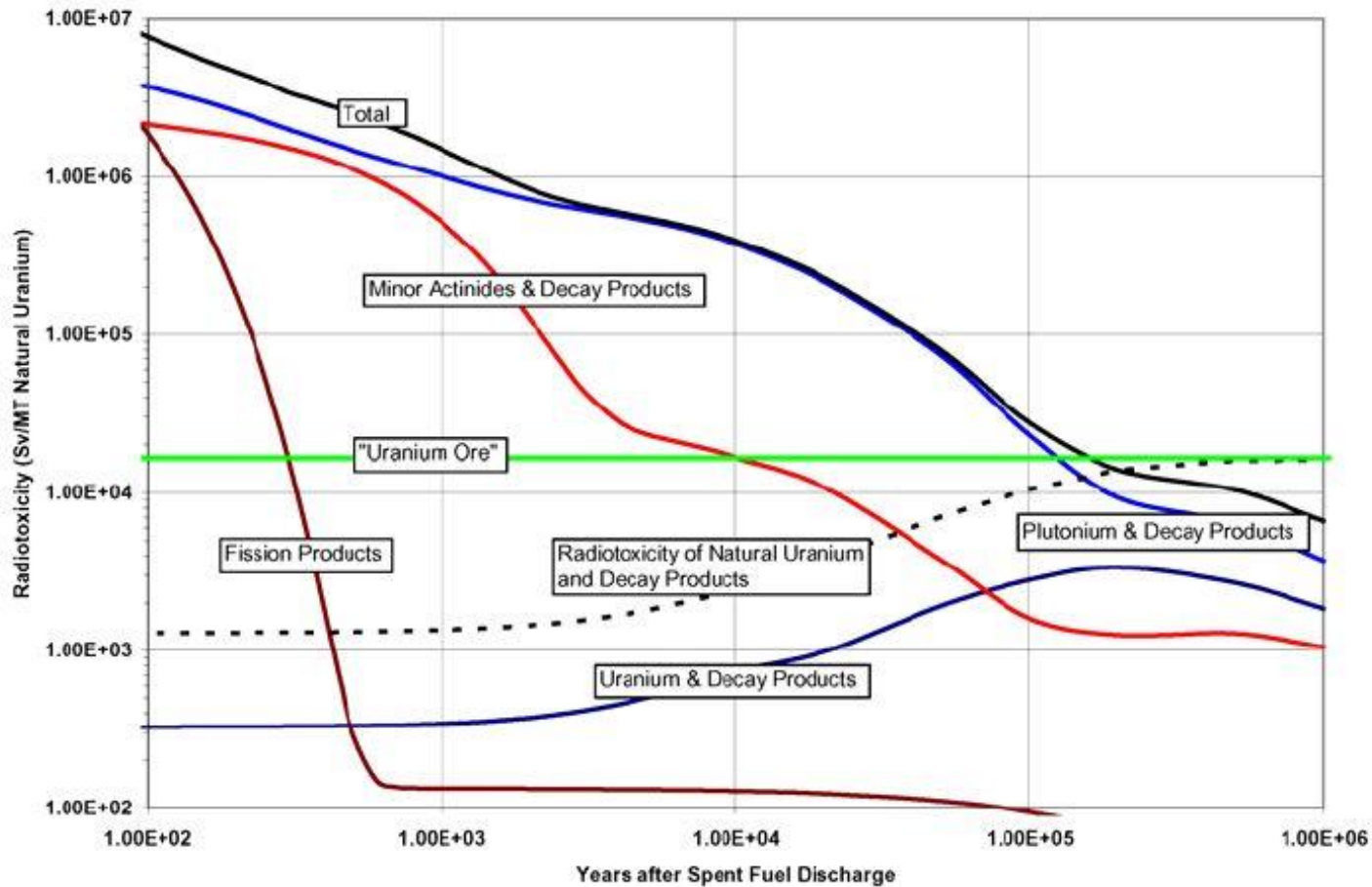

Actinide transmutation paths

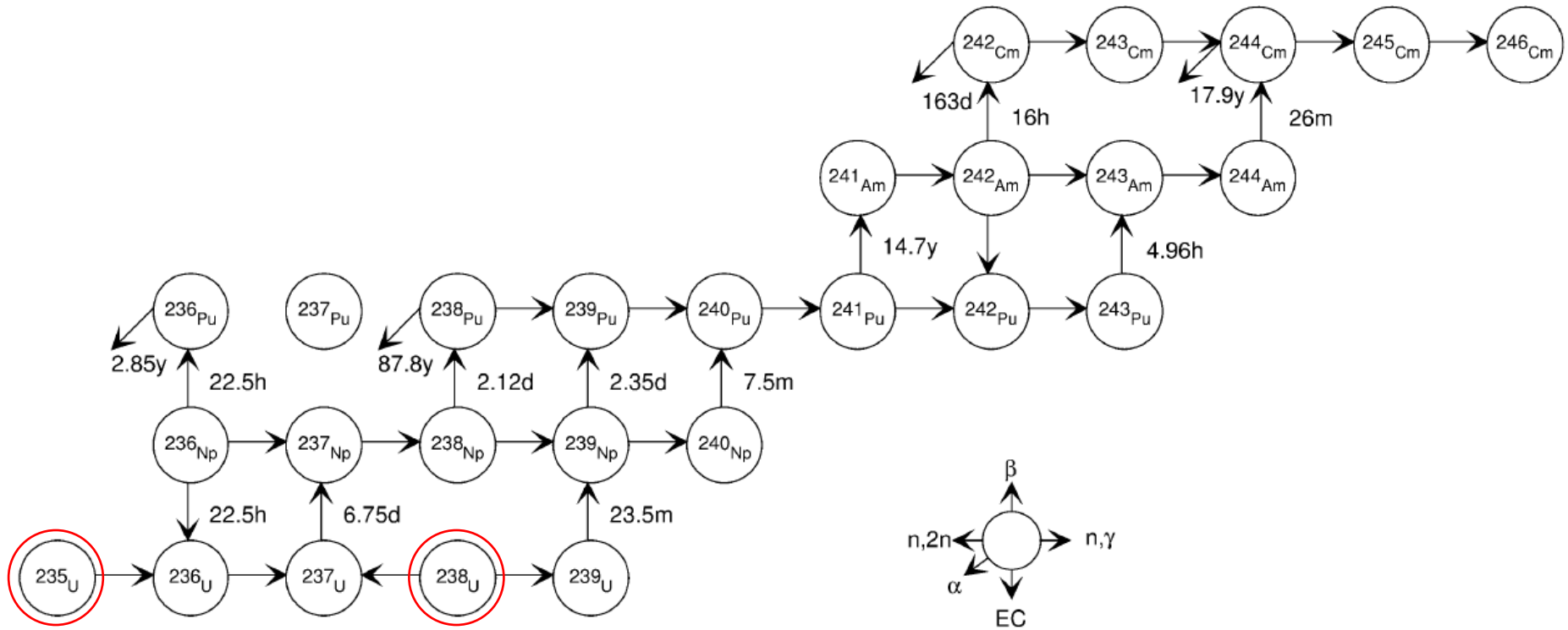

Neutron “budget” for transmutation

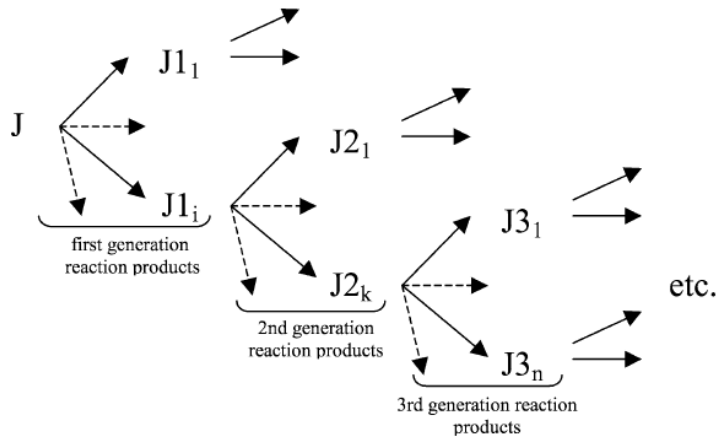

$P_{JN \rightarrow J(N+1)}$ - probability to transform JN into $J(N+1)$
 R_x - neutron loss (or gain) due to appearance of x

$$R_x = \begin{cases} 1 & \text{for a transmutation by neutron capture,} \\ 0 & \text{for radioactive decay,} \\ 1 - \nu & \text{for fission,} \\ -1 & \text{for (n, 2n) reactions,} \\ \text{etc.} & \end{cases}$$

$$D_J = \sum_{J_{1_i}} P_{J \rightarrow J_{1_i}} \left\{ R_{J_{1_i}} + \sum_{J_{2_k}} P_{J_{1_i} \rightarrow J_{2_k}} \times \left[R_{J_{2_k}} + \sum_{J_{3_n}} P_{J_{2_k} \rightarrow J_{3_n}} \times \dots \right] \right\}$$

D_J = # of neutrons needed to transform nuclide J and its daughters into FP

Comparison of D for fast and thermal reactors

- $D > 0$ implies a source of neutrons is required
- $D < 0$ implies net excess of neutrons

Isotope (or fuel type)	Fast spectrum	Standard PWR [*]
^{238}U	-0.62	0.07
^{238}Pu	-1.36	0.17
^{239}Pu	-1.46	-0.67
^{240}Pu	-0.96	0.44
^{241}Pu	-1.24	-0.56
^{242}Pu	-0.44	1.76
^{237}Np	-0.59	1.12
^{241}Am	-0.62	1.12
^{243}Am	-0.60	0.82
^{244}Cm	-1.39	-0.15
^{245}Cm	-2.51	-1.48
D_{TRU}^*	-1.17	-0.05
D_{Pu}^*	-1.10	-0.20

^{*} Value for fuel as unloaded from UOX PWR.

Repository “Densification” Factors

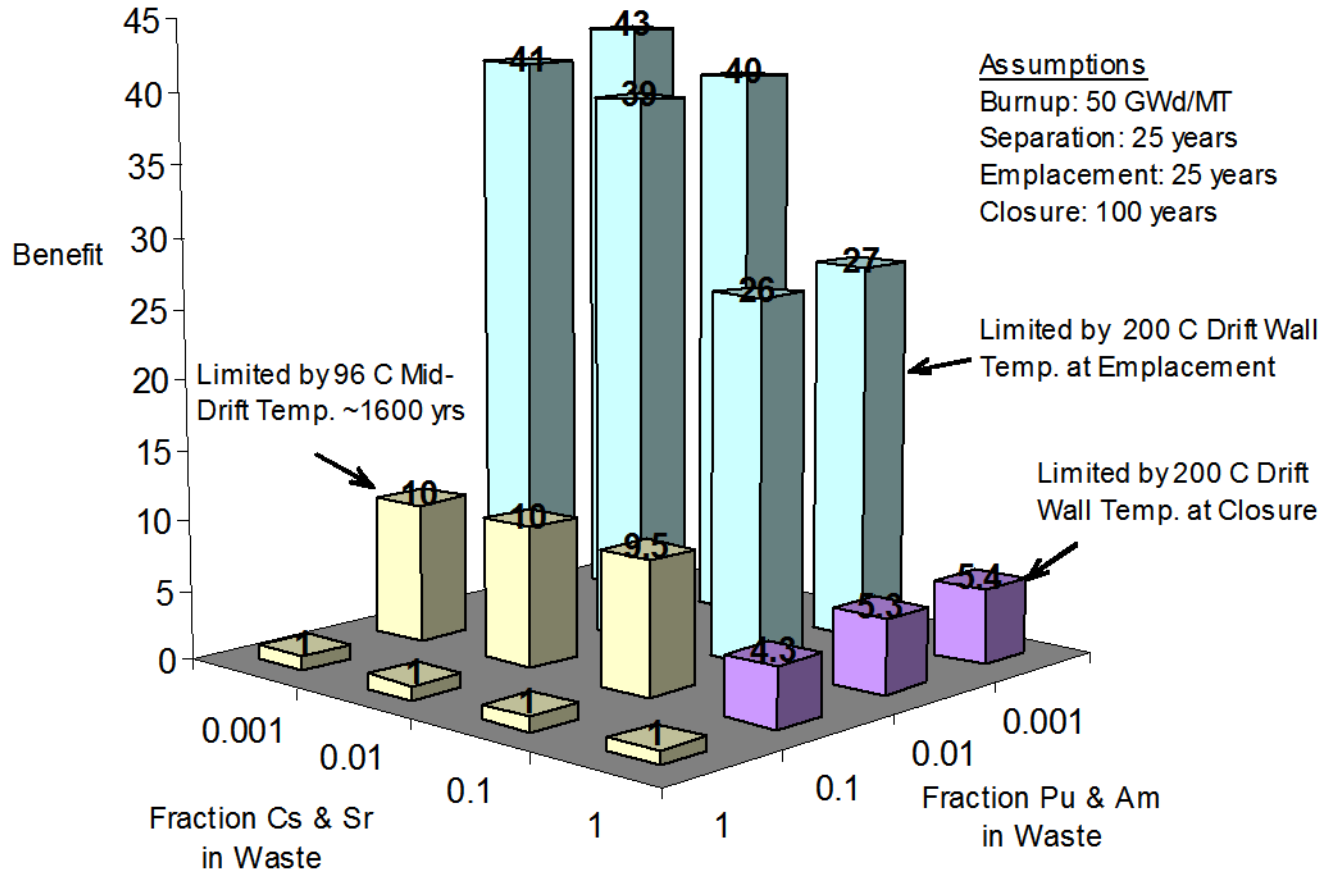

Fast reactor design decision logic

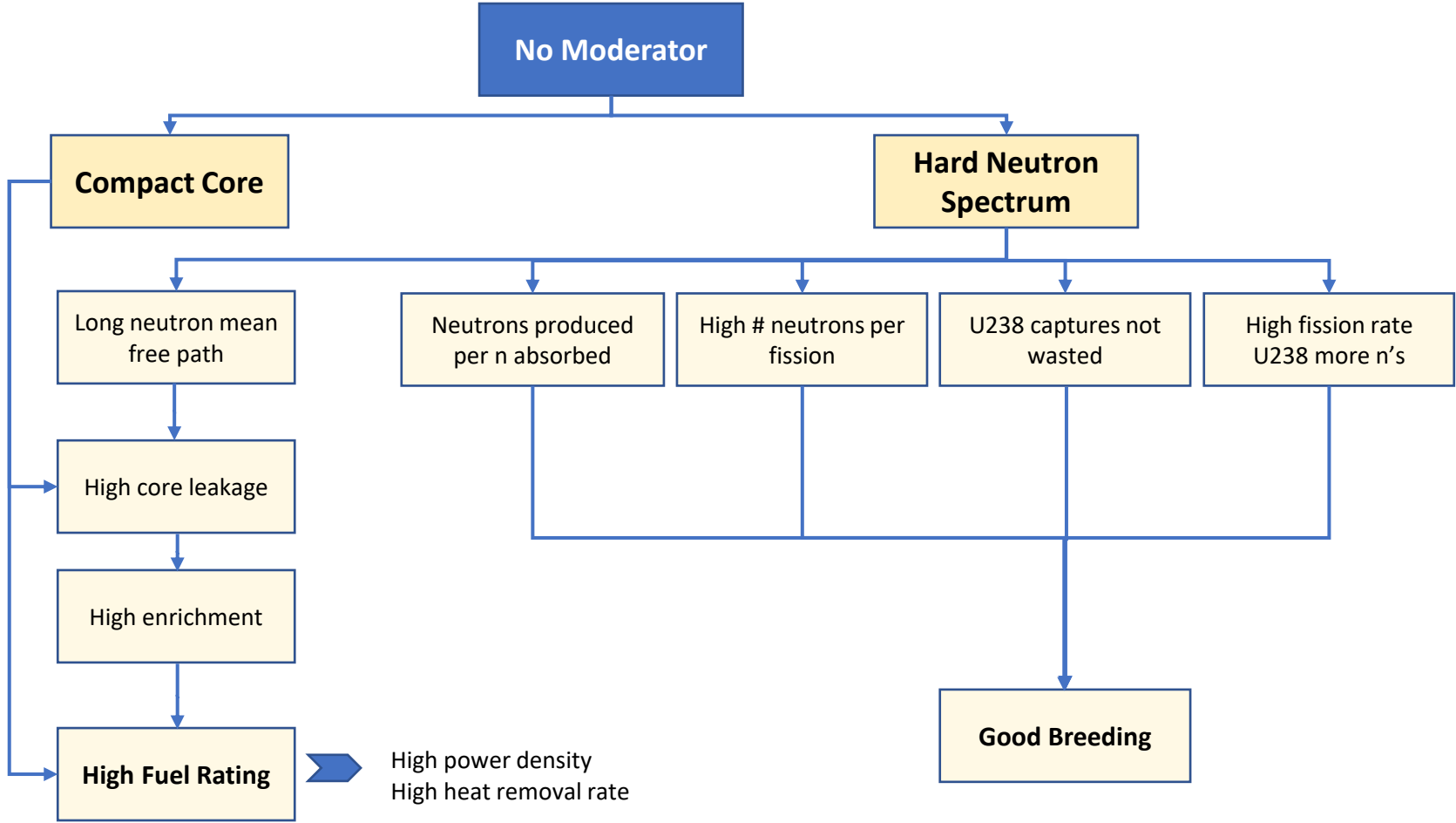

Fast Breeder Reactor design features

- All neutron cross sections are lower at high energies (about $\times 1/10$)
 - The core is more transparent to neutrons \rightarrow High leakage
 - Need higher neutron flux ($\times 10$) for a given power
- Higher enr. and/or HM density is needed for criticality (to keep λ short)
 - 15-20% vs. 3-5% in thermal spectrum
- Radiation damage to structures due to hard spectrum and high flux
 - Typical damage to the clad is 100-200 dpa vs. 1-2 dpa in LWRs
 - Radiation damage (not reactivity) often limits the fuel lifetime
- High power density and burnup are required to compete with LWRs
 - Up to 300 W/cm^3 vs. 100 W/cm^3
 - Over 150 MWd/kg vs. 50 MWd/kg



Fast Breeder Reactor design features

- Fertile blankets (heterogeneous core) are used to capture leaking neutrons
 - High proliferation risk, as nearly weapons grade Pu is generated
 - Recent designs avoid using radial blankets altogether
- Very hard neutron spectrum (many excess neutrons)
 - Minimize coolant volume fraction
 - High density fuel (U-Zr alloy, UN¹⁵, UC)
 - Positive coolant thermal expansion (and void) coefficient
 - Reduced Doppler Coefficient
- Must rely on other reactivity feedbacks for stability and shutdown
 - Leakage is increased with spectrum hardening
 - Core geometry changes due to thermal expansion



Fast Reactor Coolants: Sodium

- Melting point = 97°C → requiring trace heat to avoid freezing
- Na-K eutectic has been used to reduce melting point
- Boiling point = 883°C → boiling to be avoided because of positive void coefficient
- Neutron activation in core → need for secondary circuit

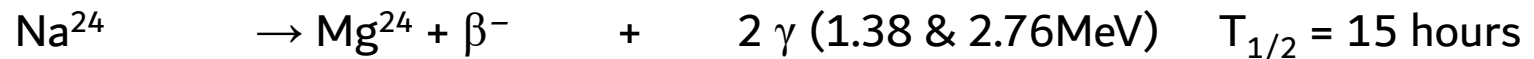
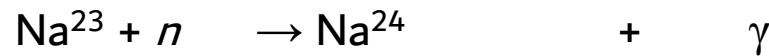

- Compatible with stainless steels, low corrosion
- Potential for reaction with water and release of corrosive products & hydrogen



Fast Reactor Coolant - Lead

- Extremely corrosive
 - Limits flow velocity to **2 m/sec** to maintain protective oxide layer
 - Results in large flow area and low power density (comparable to PWR)
- Chemically and neutronically inert
 - No need for intermediate loop
- High boiling point = 1750 °C
 - No danger of voiding in the core
- High melting point = 327 °C
 - May freeze in overcooling accidents (MSLB)
 - Complicates maintenance
 - Pb-Bi eutectic is used in Russian submarines → Po activation becomes an issue
- High (absolute) thermal expansion → efficient natural convection



Fast Reactor Safety

- Pool-type configuration is preferred over loop-type
 - Large thermal inertia of coolant
 - Less piping
 - Natural circulation to conduct heat to the vessel surface
 - Vessel surface is cooled by natural convection of air (RVACS)
 - RVACS are insufficient for high power cores → use DRACS
- Na reactions are not catastrophic but complicate O&M and reduce reliability
- Reactivity feedbacks can stabilize the core in unprotected accidents without reaching fuel failure limits

Pool vs. Loop-type design

Pool

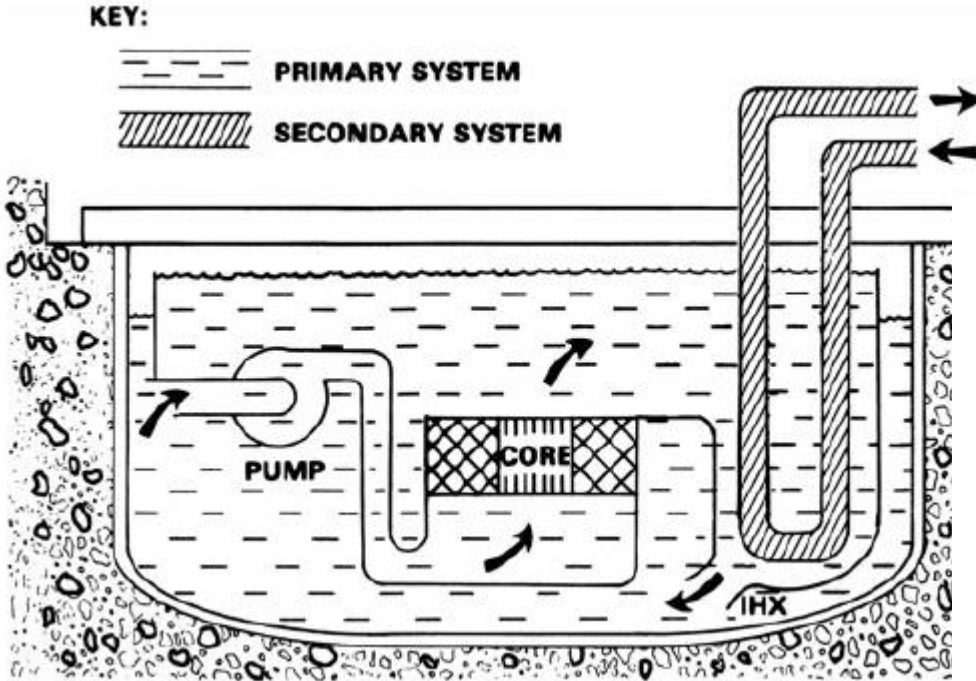

Loop

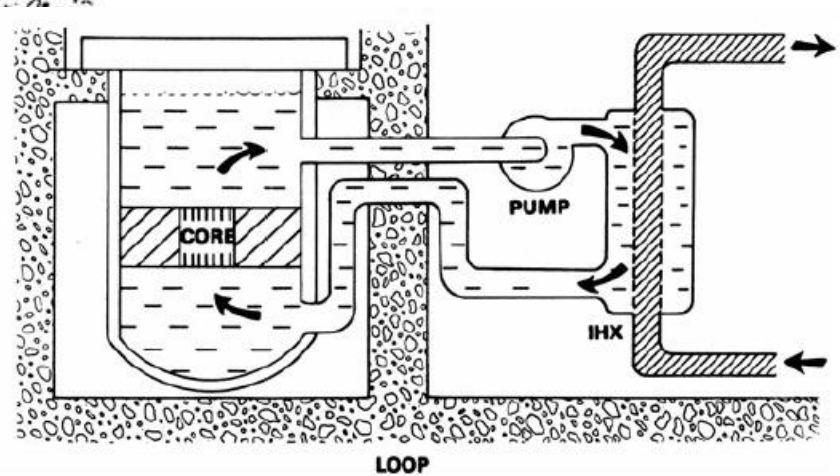

Passive Decay Heat Removal

Reactor Vessel Auxiliary Cooling System

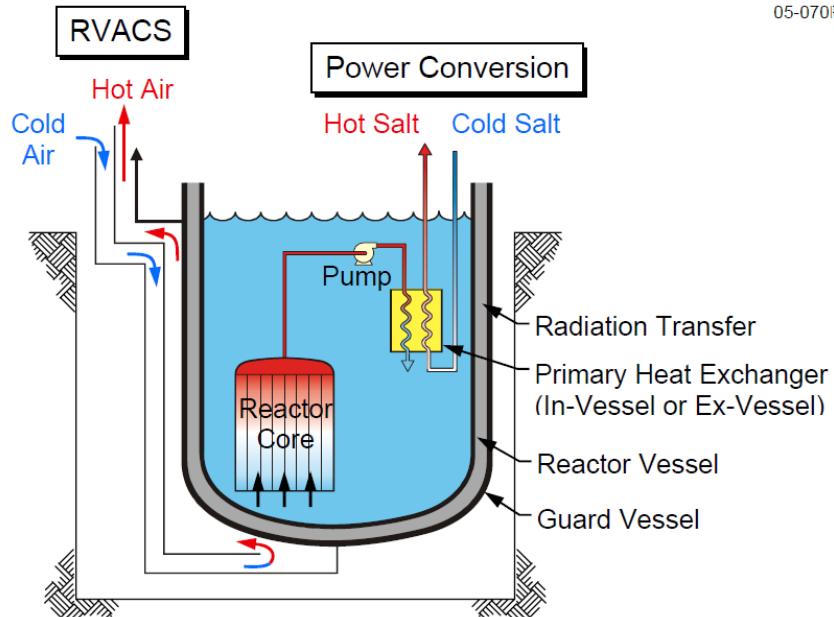

Direct Reactor Auxiliary Cooling System

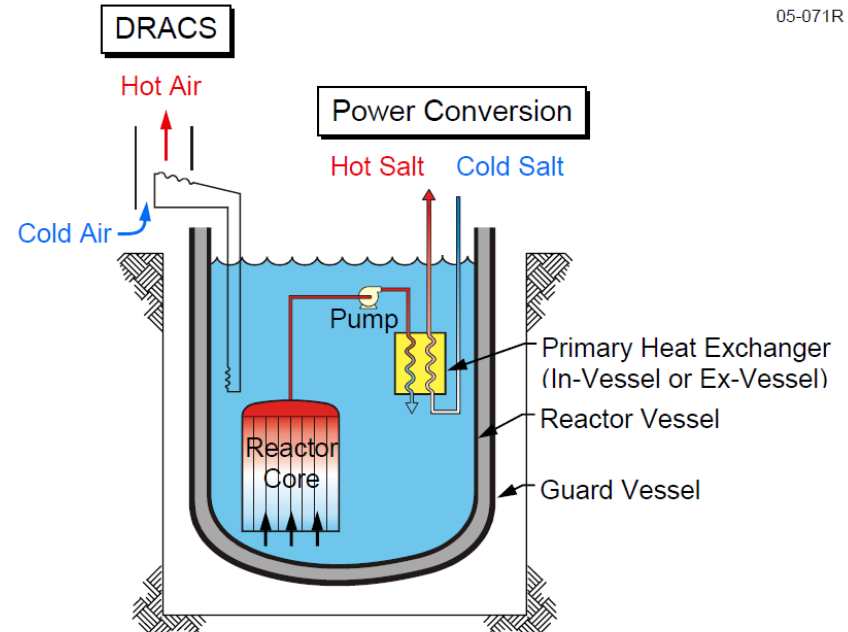

Concluding remarks

Gen IV may need re-thinking

- Better understanding of reactor technologies (SCWR, GFR?)
- Technological and commercial justification for recycling
- Advances in U exploration and extraction (sea water)
- Successful siting and licensing of spent fuel repositories
 - Finland, Sweden, WIPP, dry-casks, boreholes (Deep Isolation)
- Shift in societal priorities
 - Waste transmutation and fuel availability are not as acute as in 2002
 - Costs, non-power applications and energy security are more important
 - Salt-cooled reactors are simpler MSR without breeding and recycling

Thank you!

GFR Technology Overview, ALLEGRO Concept

Petr Vácha, UJV Rez

SafeG summer school, Rez, CZ, 29.8.2022

SafeG^{••}

SAFETY OF GFR THROUGH INNOVATIVE MATERIALS,
TECHNOLOGIES AND PROCESSES



This project has received funding from the Euratom H2020 programme
NFRP-2019-2020-06 under grant agreement No 945041.

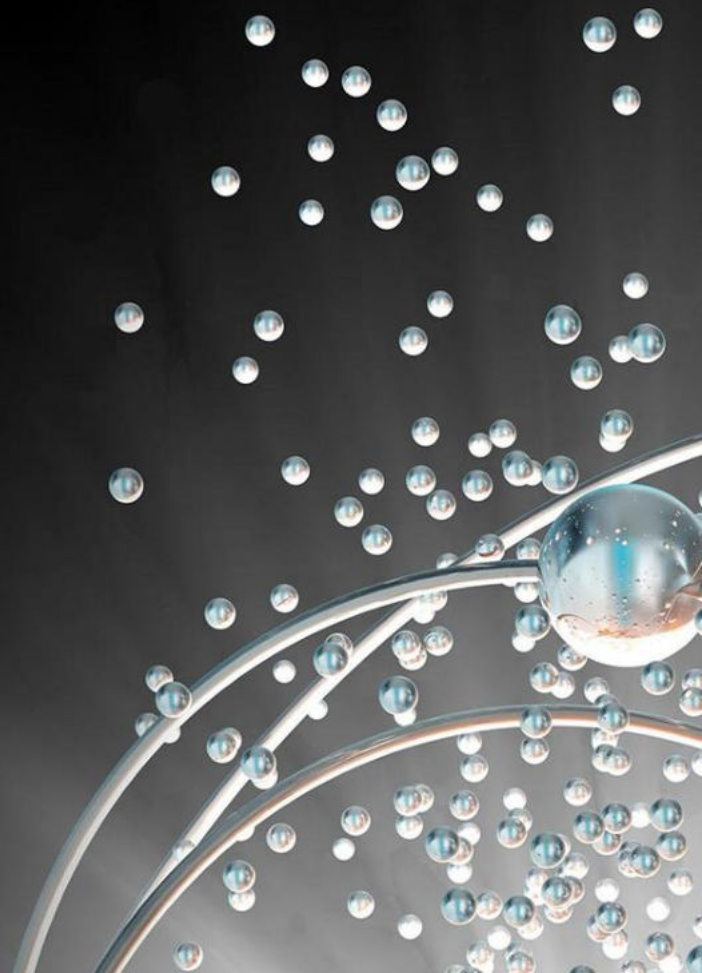

Outline

- I General overview
 - GFR history and pros/cons
 - Design process of a new reactor technology
 - Ongoing GFR research in Europe

- II ALLEGRO
 - Overview
 - Description of main systems and components of the primary circuit
 - Safety concept

I GENERAL OVERVIEW

GFR- Gas-cooled fast reactor

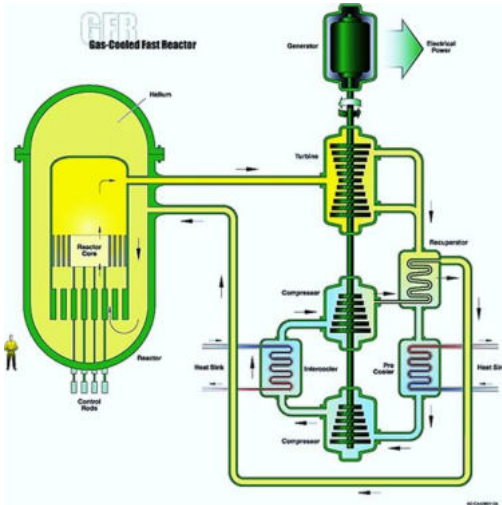

Source: www.gen-4.org

- **Combination of FAST and HIGH-TEMPERATURE reactor**
 - Closed fuel cycle
 - Waste minimalization
 - High-potential heat production, electricity production with high efficiency
- **Main features:**
 - + High core outlet temperature (>850 °C)
 - + Good neutronic safety (for a fast reactor)
 - + Transparent, chemically inert coolant
 - + Very effective breeder or burner
 - Less effective cooling (than water, molten metals or salts)
 - Extreme demands on material properties
- **Challenges:**
 - Core cooling during LOCA
 - Fuel handling at elevated pressure in the primary circuit

History of GFR

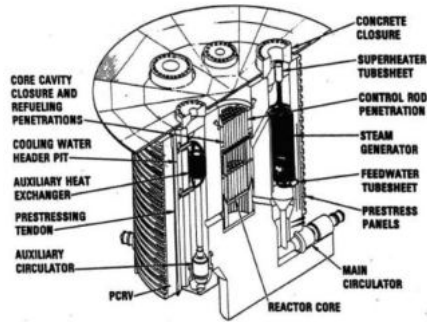

70's - Konzept GCFR 300 MWth
General Atomics



2002 – ETDR, CEA

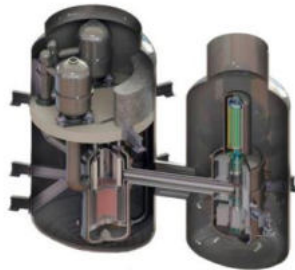

2009 – EM², GA

- **Surprisingly rich:**
 - Dates back to the 60's – first wave of fast reactor development
 - Concepts developer in Europe, USA, USSR, Japan
 - Never built – too ambitious and demanding on materials and technologies of the era + success in SFR development

- **Modern Era**
 - GFR as one of the GIF technologies for the 21st century
 - R&D Focused in Europe, USA and Japan

History of GFR – gas-cooled reactors

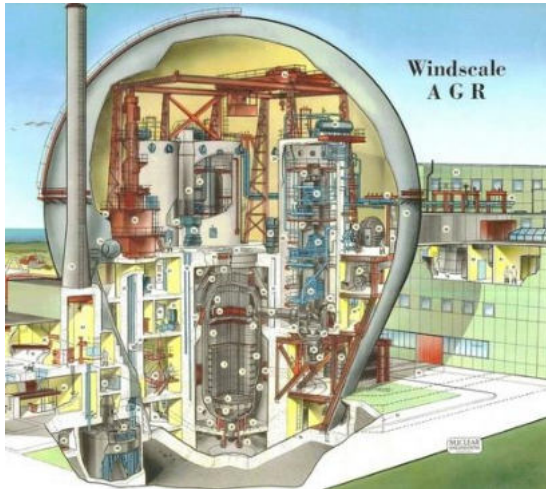

1965 – AGR, theengineer.co.uk

- **Gas-cooled reactors with moderator:**
 - Rich history of commercial operation (since the end of 50's)
 - MAGNOX and AGR in Great Britain
 - Helium-cooled reactors in Germany, USA, Japan, China
 - In total – more than 500 reactor-years of experience

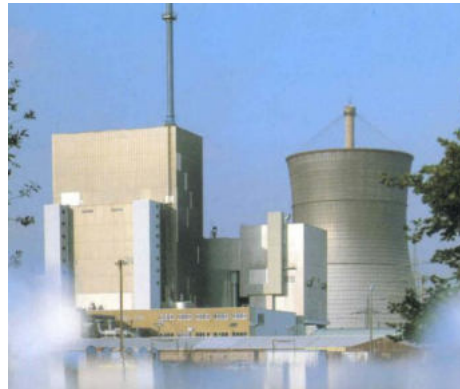

1985 – THTR 300, thtr.de

What is the position of GFR now?

???

Large (R&D) project – Phases

- **5 stages of development:**

- **Idea** – No technical solution, just an idea that something can exist
- **Pre-conceptual design** – rough technical solution, basic principles explained
- **Conceptual design** – well-formulated technical solution lacking fine details
- **Basic design** – fine details solved – materials to be used, manufacturability of parts etc.
- **Detailed design** – Manufacturing documentation level of detail

- **Sometimes only 3 stages are used:**

- Idea
- Conceptual design
- Detailed design

- **Can apply to a whole project or to individual systems and components**

Phases of development – New Nuclear reactor technology (1)

Phase	Main activities	Fulltime workforce required	Budget
Idea	An idea, e.g. „What about a reactor with the fuel in form of gas“ and its crude elaboration	1	Virtually 0
Pre-conceptual	Basic analyses for proof of viability of the concept: <ul style="list-style-type: none">• Does it work as intended?• Is it safe?• Is it viable (cost vs benefits)?• Is it, in general, possible to build?	~ 10	~ 10 million €
Conceptual	Detailed calculations, complex experiments, detailed safety concept, first prototypes of main components, design of I&C system First contact with potential industrial/business partners	~ 50	~ 100 million €
Basic design	Very precise design of all the main components and systems, including its manufacturability, potential suppliers, etc. Preparation of the supply chain to build the FOAK unit	Hundreds	~ 1 billion €

Phases of development – New Nuclear reactor technology (2)

- **Each step = exponential growth in complexity**
 - Therefore, also in budget and people needed
 - Most of the work is invisible to the outside – very little difference for outsiders between a finished pre-conceptual design and finished basic design
- **Financing:**
 - Unrealistic to reach (in a reasonable timeframe) more than mature pre-conceptual design of a reactor using just public money from grants and research projects – some bigger framework needed to finish at least the conceptual stage
- **Modern technologies (CAD, CFD, etc.):**
 - Allows to present projects at the level of idea as projects entering basic design stage to the outside
 - Hundreds of reactor „concepts“ worldwide, basically none has enough financing to finish the development

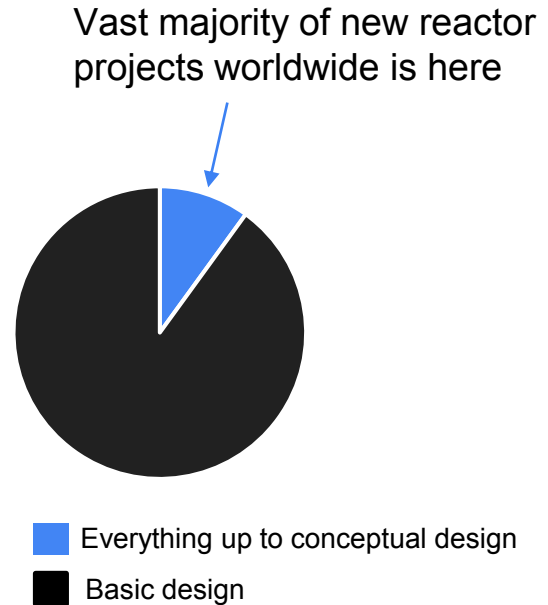

GFR/ALLEGRO R&D projects in Europe

- 9 ongoing national projects in Czechia
- 1 ongoing international (H2020) project
- Several finished national and international projects in Europe in the course of the last 15 years

Name	Duration	Main goal	Total budget (M€)
SafeG	2020-2024	Complex project on GFR development	4.5
NOVA	2018-2022	Development of sacrificial materials for core catchers of GFRs	0.7
REDEAL	2018-2024	Testing of construction materials in gaseous environments at extreme conditions (high temperature, corrosive environments)	1.3
MKM	2018-2024	Development of a new class of Zr based alloys and high entropy alloys with optimized properties for Nuclear industry	1.7
ALLEGRO	2018-2025	Design and testing of key systems and components for ALLEGRO	1.9
SODOMAHe	2019-2025	Stability and resistance of materials for high-temperature helium-cooled reactors	2.8
MATPRO	2020-2024	Development of "better concrete" for extreme conditions	0.7
KOBRA	2020-2023	Development of a passive safety systems for GFRs/VHTRs based on prolongation of primary compressor rundown by utilization of decay heat	1.3
PMATF	2020-2023	Methods for the characterization, testing, and qualification of irradiated samples of ATF materials	1.6
VELEMLOK	2022-2025	Development and testing of very-high temperature materials and prototyping of components	1.2
Total:			17.7

GFR R&D projects -> R&D program

- **New projects are formulated based on a wider picture of both the finished and ongoing activities**
- Utilization of synergies, newly acquired know-how, new knowledge

- **Several R&D topics developed into more complex R&D programs**

Development of components and systems

- Projects ALLEGRO, NOVA and MATPRO – development of systems and components accompanied by targeted material development

Development, construction and operation of electrically heated GFR Mockup

S-ALLEGRO facility in Pilsen, Czech Republic. Developed by CVR, ATEKO and UJV Rez, in operation since 2020

STU helium loop in Trnava, in operation since 2019

Material research and development

Projects SODOMAHe, REDEAL and MKM in synergy, Obtained knowledge being utilized in design of components for the GFR

Helium technologies

Consecutive projects TEQUILA, CIPERA, and REGNET dealing with coolant purification and helium sealing, each with increasing level of detailed and enlarged scope, utilizing the HTHL facility in Rez

S-ALLEGRO mockup and STU helium loop

• S-ALLEGRO

- Located in Pilsen, Czech Republic
- Integral facility, electrically heated mock-up of ALLEGRO in 1/75 scale
- Helium at 7 MPa, max. outlet T 850°C, max. power 1 MW
- Available for both thermal-hydraulics experiments and out-of-pile testing of scaled-down components



• STU helium loop

- Located in Trnava, Slovakia
- He loop for studying natural circulation cooling
- Helium at 7 MPa, max. outlet T 520°C, max. power 220 kW



Helium Technologies R&D

- **Test-facilities for separation of impurities/gases from gaseous media**

- **Performance of Helium purification unit in the HTHL1 loop (CV Rez)**

- Purification unit (H₂, CO, CO₂, CH₄): Mech. filters, Room-T mol. sieves, CuO bed 250 °C, Adsorber -70 °C
- Doping unit & Analytical unit (Gas chromatograph & optical hygrometer)
- Out-off pile training facility

Scheme of the HTHL1 loop

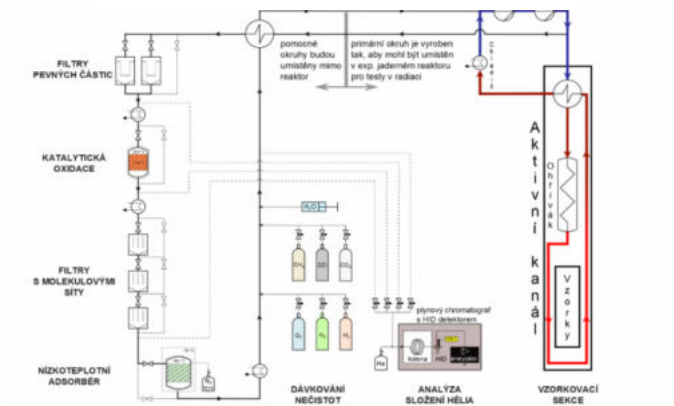

View of the HTHL1 loop purification unit

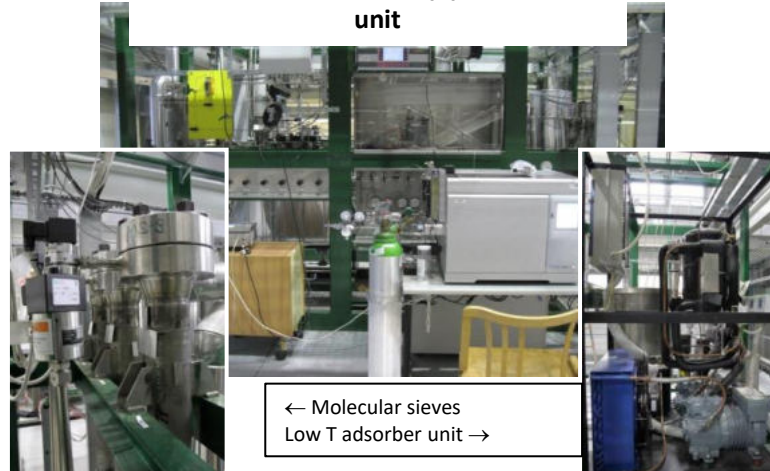

← Molecular sieves
Low T adsorber unit →

Why GFR?

- **Many theoretical benefits**

- **Very high temperature combined with fast spectrum** – Unique, since gaseous coolant ensures no unwanted phase changes and limited-to-none chemical interactions -> theoretically unlimited temperature, while keeping the benefits of a fast reactor
- **Versatile** – the above-mentioned combination opens possibilities to utilize the heat in many ways simultaneously (hydrogen production, chemical industry, electricity production, heating)
- **Development point of view** – radically new technology, big advantage on an over-saturated market (many more concepts than could be ever realized)

Potential applications of GFR heat in chem. industry

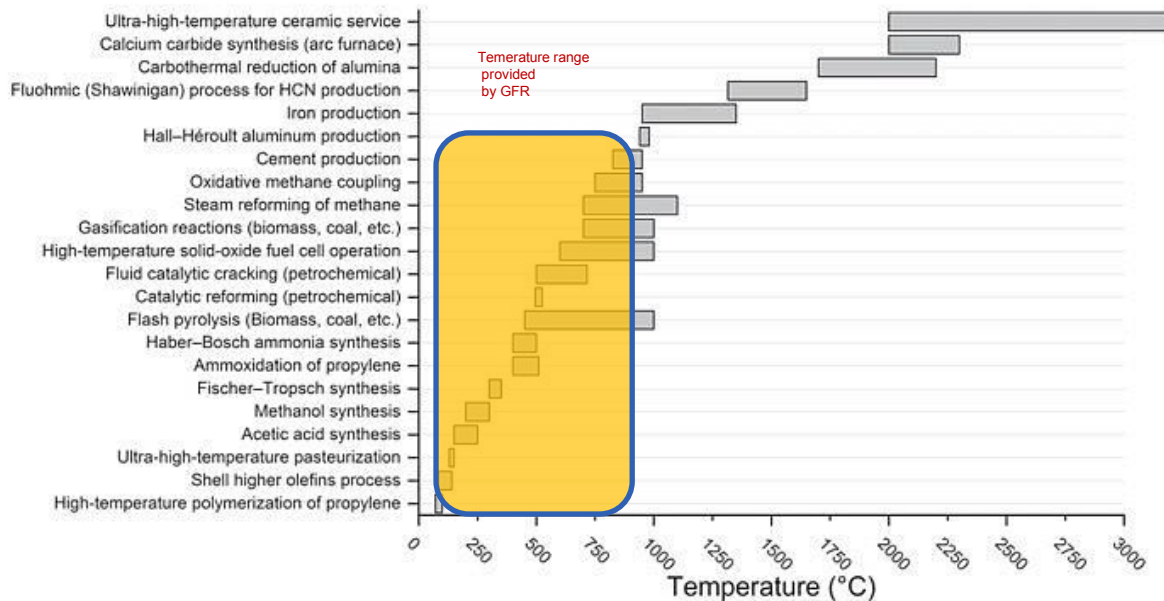

II ALLEGRO TECHNOLOGY

The ALLEGRO Project

- **Gas-cooled Fast Reactor technology demonstrator**

- 75 MWth, 850°C core outlet temperature

- **Developed within international collaboration**

- V4G4 CoE – 6 organizations from 5 countries (CZ,HU, SK,PL + FR)
- Increasing numbers of officially collaborating organizations
- Origins of the design in the early 2000's

- **ALLEGRO as a demonstration unit**

- Three main goals:
 - Technology demonstration (first-of-the-kind)
 - Proof of safety concept of GFR
 - Fuel qualification

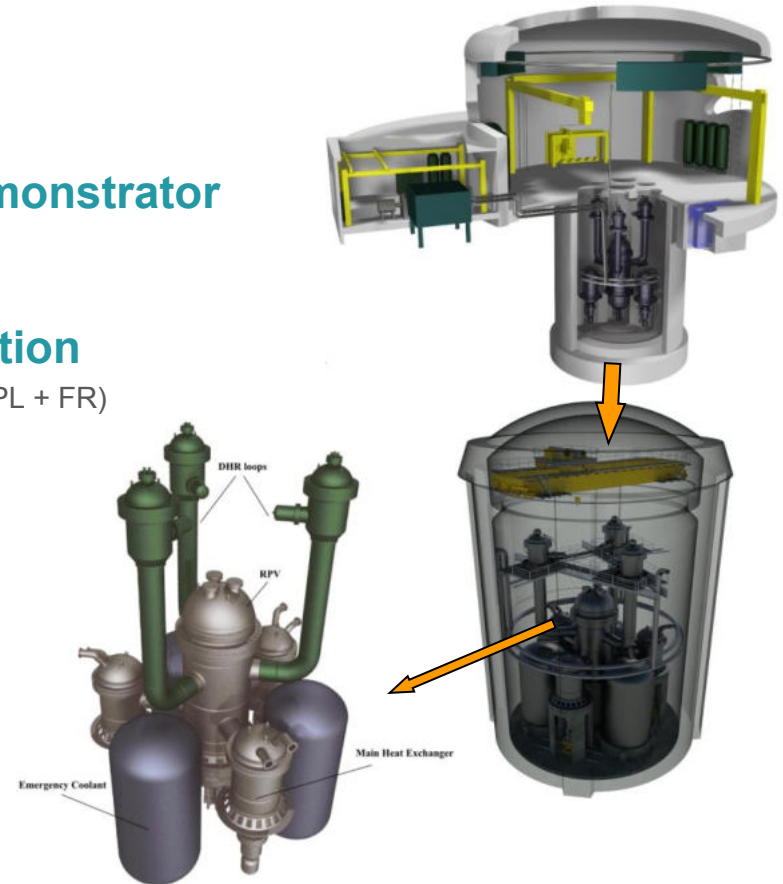

V4G4 CoE

• International collaboration

- V4G4 CoE – 6 organizations from 5 countries (CZ,HU, SK,PL + FR)
- Increasing numbers of officially collaborating organizations

• V4G4 Centre of Excellence

• Full members (alphabetically):



Centre for Energy Research, Hungary



National Centre for Nuclear Research, Poland



ÚJV Řež, a.s., Czech Republic



VUJE, a.s., Slovakia

• Associated members (alphabetically)



Alternative Energies and Atomic Energy Commission, France



Research Centre Řež, Czech Republic

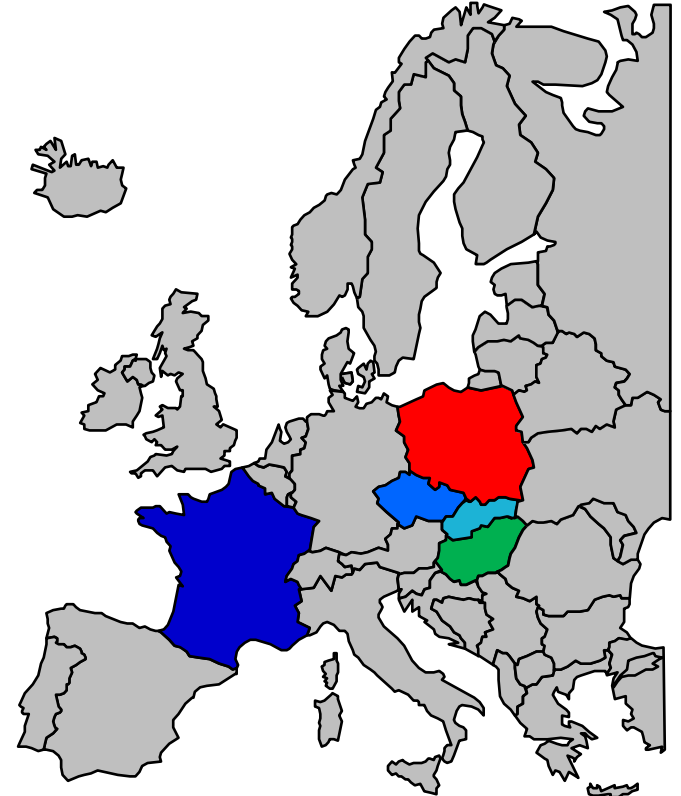

ALLEGRO – design overview

- **Two consecutive core configurations**
 - Driver core – MOX/UO₂ pin-type fuel in steel cladding, experimental positions for fuel qualification
 - Refractory core – (U,Pu)C pin-type fuel in SiC-SiCf cladding <- GFR reference fuel
- **Target core outlet temperature 850°C**
- **Power density up to 100 MW/m³**

ALLEGRO main characteristics	
Nominal Power (thermal)	75 MW
Driver core fuel/cladding	MOX(UO ₂) / 15-15ti Steel
Experimental fuel/cladding	UPuC / Sic-Sicf
Fuel enrichment	35% (MOX) / 19.5% (UO ₂)
Power density	100 MWth/m ³
Primary coolant	He
Primary pressure	7 MPa
Driver core in/out temperature	260°C / 530°C
Experimental fuel in/out T	400°C / 850°C

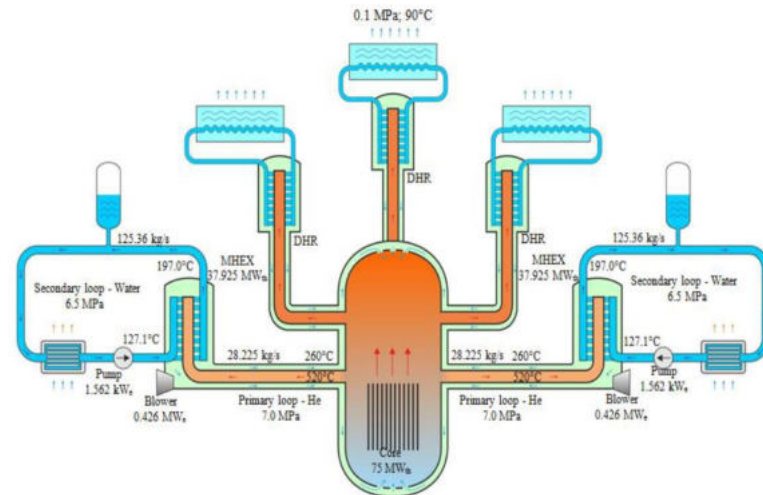

ALLEGRO – Main goals

- **ALLEGRO should achieve:**
 - Demonstration of viability of the GFR technology
 - Proof of concept – ability to deliver high-potential heat while remaining safe and reliable
 - Testbed– qualification of materials and technologies in prototypical conditions
- **Ultimate goal – Qualification of the GFR technology for commercial application**

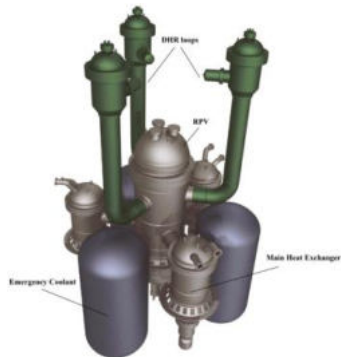

ALLEGRO

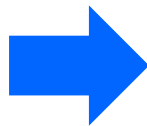

Commercial
GFR



GFRs as SMR

- **Reference GIF GFR – 2400 MWth**

- Excellent theoretical efficiency
- Very ambitious – lots of unresolved issues concerning safety and technology

- **ALLEGRO**

- Basis for large scale GFR
- Some safety systems developed for Allegro may not scalable to 2400 MWth
- Safety systems would be applicable for a reactor with ~ 200-600 MWth
- ALLEGRO could be basis for SMR GFR

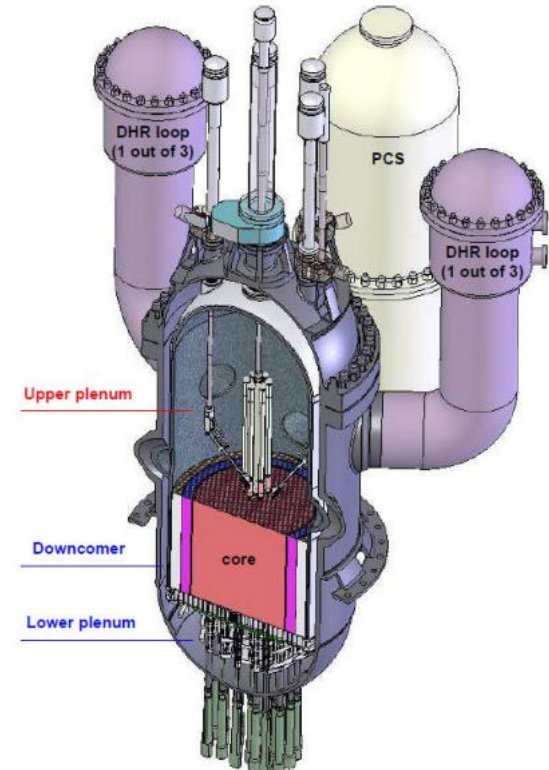

HeFASTo - Helium-cooled Fast Reactor



- **A concept of Advanced Modular Reactor based on the GFR technology:**
 - Developed by ÚJV Řež, a. s.
 - Closed fuel cycle actively counting with reprocessing of spent fuel from PWRs
 - High level of modularity and very long fuel campaign – increase in economic competitiveness
 - Fully passive safety and proliferation resistance compliant with GENIV goals

HeFASTo – MAIN PARAMETERS

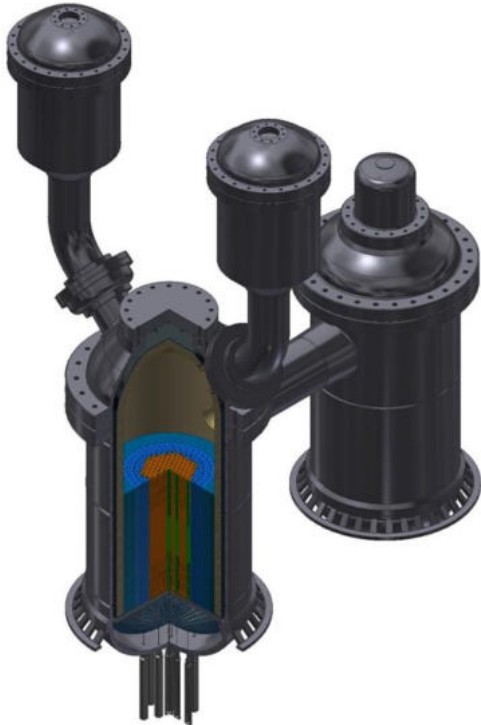

- **Main Features of HeFASTo**

- Indirect power conversion cycle – modularity of the secondary circuit
- Two-layer containment protecting from external hazards and release of RN
- Placed partially underground – only 18m above ground
- 5 years of operation without the need for fuel handling

Parameter	Value	Unit
Thermal power	200	MWth
Core inlet/outlet temperature	450 / 900	°C
Primary coolant	He	-
Primary pressure	7,5	MPa
Secondary coolant	N2+He	-
Secondary pressure	8,0	MPa
Fuel	UC or(U,Pu)C	-
Fuel enrichment	UC - 19,5 (U,Pu)C - 30	%
Operation time without outage	5	years
Load factor	>95	%

ALLEGRO Fuel



Fuel pellet, wikipedia commons

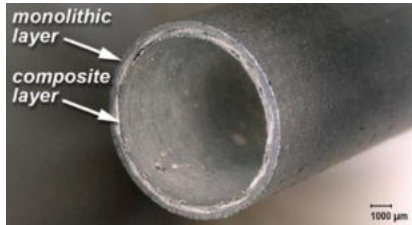

General Atomics SiGA[®]
SiC composite cladding tube



ALLEGRO fuel pin

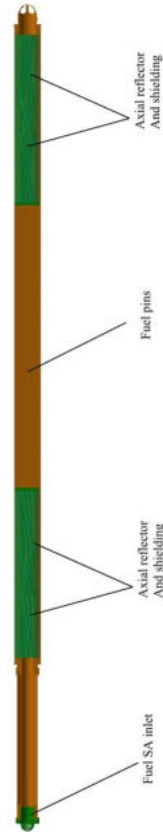

ALLEGRO fuel assembly

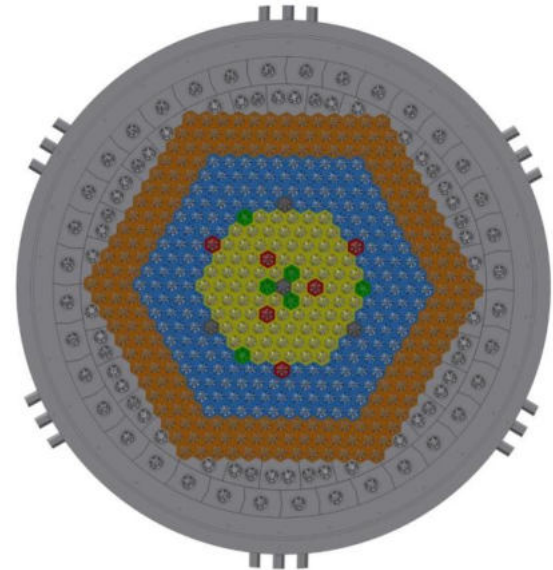

ALLEGRO RPV cross-section

GFR Fuel handling - basics

- **Pressure in the system:**
 - At pressure – e.g. HTR
 - Depressurized – e.g. VVER
- **At pressure – advantages and disadvantages**
 - + shorter cool-down period after reactor shutdown
 - + better safety in case of SBO
 - - cannot open the RPV head
 - - Fuel handling machine quite complicated
- **Depressurized – advantages and disadvantages**
 - + easier manipulation and simpler fuel handling machine
 - - worse safety – SBO leaves the reactor at atm. pressure without forced cooling
 - - much longer cool-down period
 - - worse radiation situation in the GV

Fuel handling sequence proposal

- **Pressurized fuel handling selected**

- HTR-like system could not be utilized – too many small SAs
- Better safety and shorter waiting times
- It would be very challenging to correctly seal the RPV upper head multiple times

- **Basic sequence:**

- 1) Reactor shutdown, slow (after 10 minutes) rundown of main blowers to 10 % speed, close the high-pressure emergency injection system
- 2) When the core outlet temperature falls under $X^{\circ}\text{C}$, and after a predefined minimum time T , close the low-pressure emergency injection system, start to depressurize the primary circuit until it reaches Y atm. pressure
- 3) Pressurize the circuit back to Z atm. pressure with nitrogen
- 4) Connect the primary circuit to the fuel handling machine and start fuel unloading

- **Issues to be resolved**

- 1) Design of the system
- 2) Values of parameters X , Y , Z , T → several months of analyses → $X = 125$ s, $Y = 4.5$ bar, $Z = 10$ bar, $T = 1$ day

Sketch of the design

Design remarks:

Lid of \varnothing 1,35m (10cm more than \varnothing of the active core) on the top of the RPV
Plug in the core barrel upper head (not sealed, serves also as the 1 % core bypass)

Flange around the lid on top of RPV – to connect pressurized tubus (1MPa)

Tubus goes through the GV top

Fuel handling machine on top of the tubus, fuel SAs extracted through the tubus

Airlock system to communicate with the outside atm. Pressure

Dry storage – fuel SA packed into a container inside of the pressurized zone, then extracted via the airlock, empty container put inside for the next SA

Tubus and FH machine space is pre-pressurized before the lid from the top of RPV is uncovered

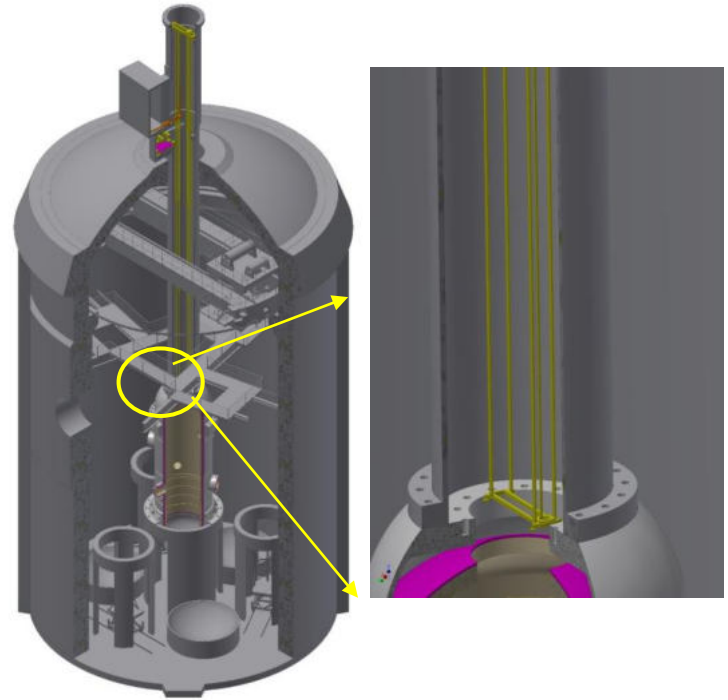

Gas-Gas heat exchanger – Background

- **Reason**
 - to reach higher secondary temperatures
 - to avoid using water in the secondary circuit
- **Has to operate under two sets of conditions – for the driver core and the refractory core configurations**
 - 260 °C / 530°C primary temperatures for the driver core
 - 400°C / 850 °C primary temperatures for the refractory core
 - Not possible to fully optimize for both configurations due to different T levels and deltaT
 - Decision – optimization for the refractory core configuration

Gas-Gas heat exchanger – Design basis

- **Reliability and Safety**

- High reliability, in-service inspections and repairs must be ensured
- Helical tube HX selected instead of modern compact plate designs due to the above-mentioned reasons
- Secondary pressure above primary pressure to suppress leakage from primary side to the secondary one – set to be 7.5 MPa

- **Performance**

- The system must be able to dissipate 120 % of total nominal heat (2 x 60 %) to accommodate uncertainties in design and possible malfunction of a limited number of tubes
- Minimization of approach temperature – maximum 20 °C for the refractory core operation

Gas-GAS HX design overview

- **344 helical tubes**
 - DN16, 2 mm wall thickness
 - Total area 248 m²
 - Average length 11.5m
 - Average inclination 10°
 - Tubes made from INCONEL 617
- **Relatively compact design**
 - Coaxial duct on both sides
 - Can be upscaled by lowering the inclination and adding more rows

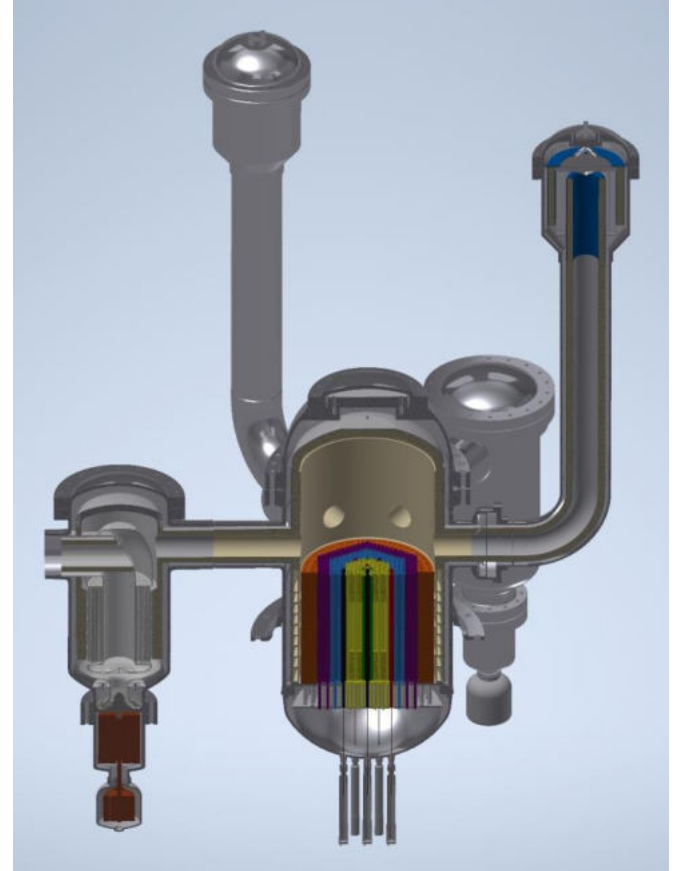

Gas-GAS HX design overview

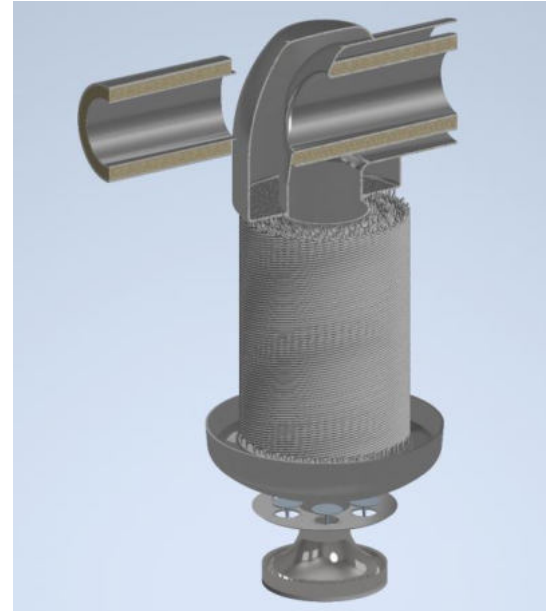
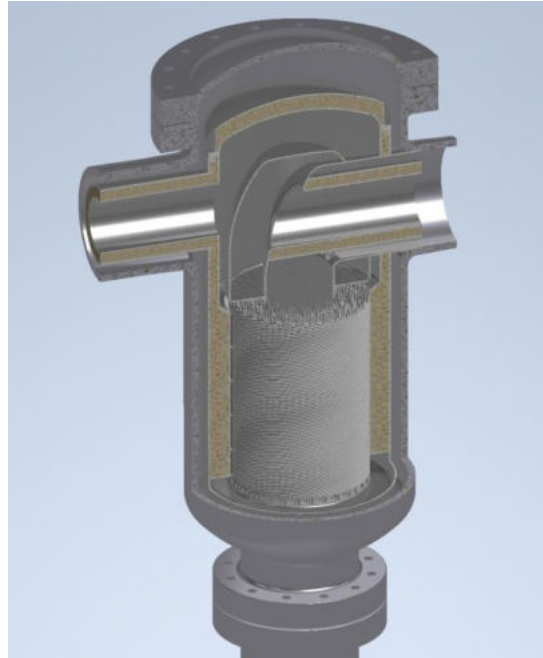
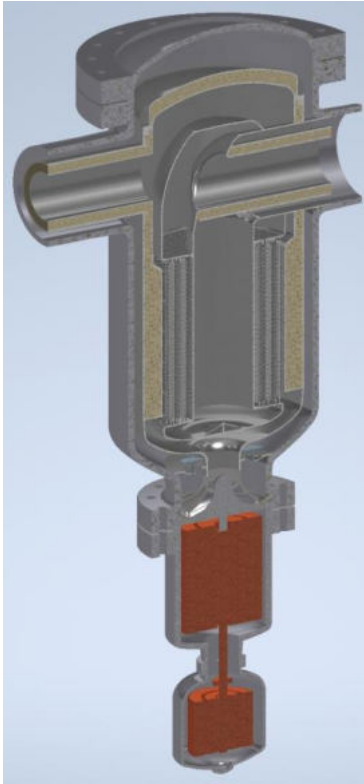

Development of the power conversion system (1)

Two principally different analyses were performed

- A. Analyses of optimal pressure ratio
 - B. Analyses of fixed pressure ratio
- Custom script developed in MATLAB, using real gas (CoolProp), efficiencies, pressure losses, in total, over 5000 cases calculated

Fixed parameters of I. circuit

$$t_1^I = 850 \text{ }^\circ\text{C}$$

$$t_2^I = 400 \text{ }^\circ\text{C}$$

$$p^I = 7 \text{ MPa}$$

Fixed parameters of II. circuit

$$t_3^{II} = 830 \text{ }^\circ\text{C}$$

$$t_1^{II} = 60 \text{ }^\circ\text{C}$$

$$\eta^T = 90\%$$

$$\eta^C = 80\%$$

$$\eta^{HE} = 98\%$$

$$dp^{HE} = 600 \text{ kPa}$$

Optimization parameters

$$p_1^{II} = 7 - 20 \text{ MPa}$$

$$\frac{p_2^{II}}{p_1^{II}} = 1.2 - 3$$

Rules to be met

$$t_2^I - t_2^{II} \geq 10 \text{ }^\circ\text{C}$$

$$p_1^{II} > 7 \text{ MPa}$$

Development of the power conversion system (2)

- Analysis of the secondary circuit – selected cycle

- Cycle without regeneration depicted
- This cycle allows for proper Rankine tertiary circuit that could significantly increase overall efficiency

Properties of nitrogen are close to properties of air, i.e., no leakage in case of He or chemical instability in case of CO₂

Simple technical configuration

Turbine outlet temperature	608 °C
Mass flow rate	274 kg/s
Volume flow rate	3.66 m ³ /s

T-s diagram

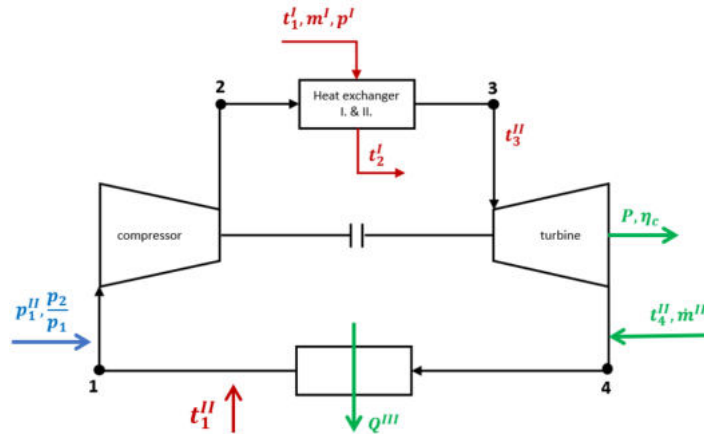
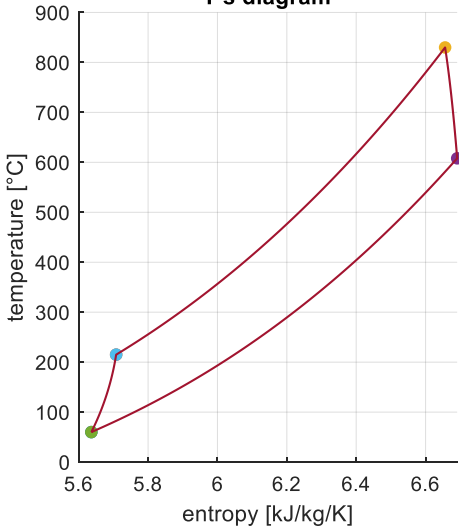

ALLEGRO Safety Concept

- **Emphasis on passive safety**

Three main (semi)passive safety systems:

- Dedicated Decay Heat Removal system – natural convection
- Emergency coolant injection system – actuated by pressure difference
- Primary containment – enhancing natural convection by keeping elevated residual pressure in LOCAs

- **Main goals of the safety concept**

- Practical elimination of severe accidents
- Minimalization of core damage even in very improbable situations like combination of station blackout and LOCA
- The result is complete elimination of radionuclides release outside of the plant

ALLEGRO Safety Concept

- Three key safety systems
 - Guard Vessel



DHR system

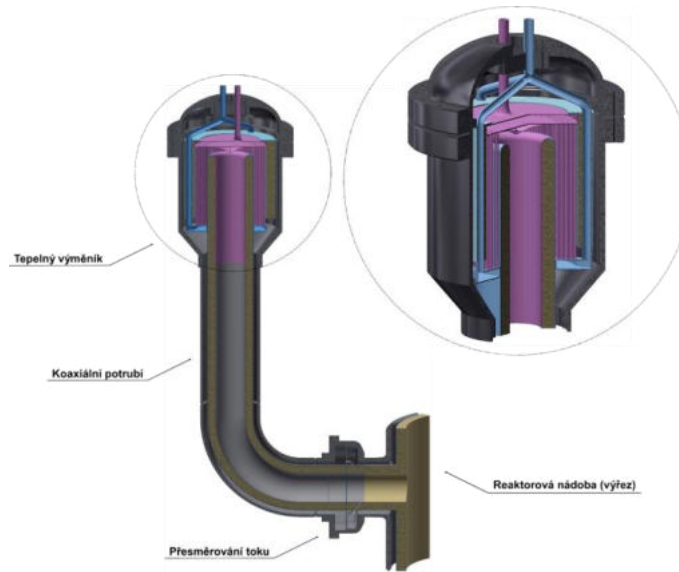

Emergency coolant injection

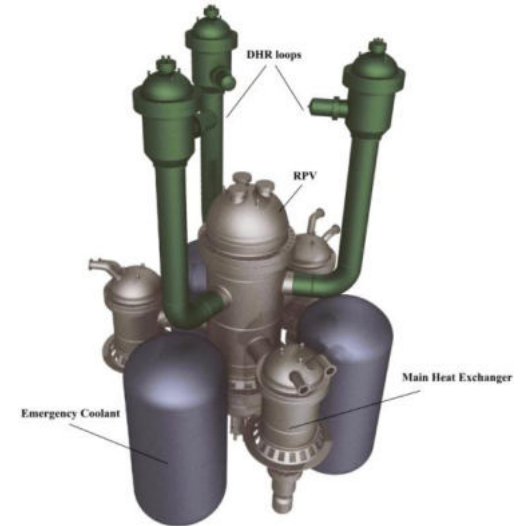

Guard Vessel

- **Pre-stressed concrete or steel close-containment**
 - Both versions under development
- **Main functions**
 - Barrier to prevent release of RN
 - Keeps elevated residual pressure in LOCAs
- **Features**
 - Free volume ~5 000 m³
 - Filled with pure N₂ at atm. Pressure in operation
 - Maximum design pressure 1,1 MPa in LOCA situation
 - Target leakage under 5 %/day at the design pressure



Decay heat removal system

- **Dedicated system:**
 - Fully passive, based on natural convection
 - Continuously pre-conditioned during normal reactor operation with a small controlled primary coolant flow
 - Key safety systems in LOFA
 - 2 x 100 % loops
 - Patented in the Czech Republic, international patent pending

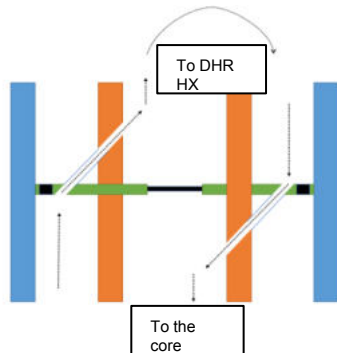

System in the pre-conditioning settings

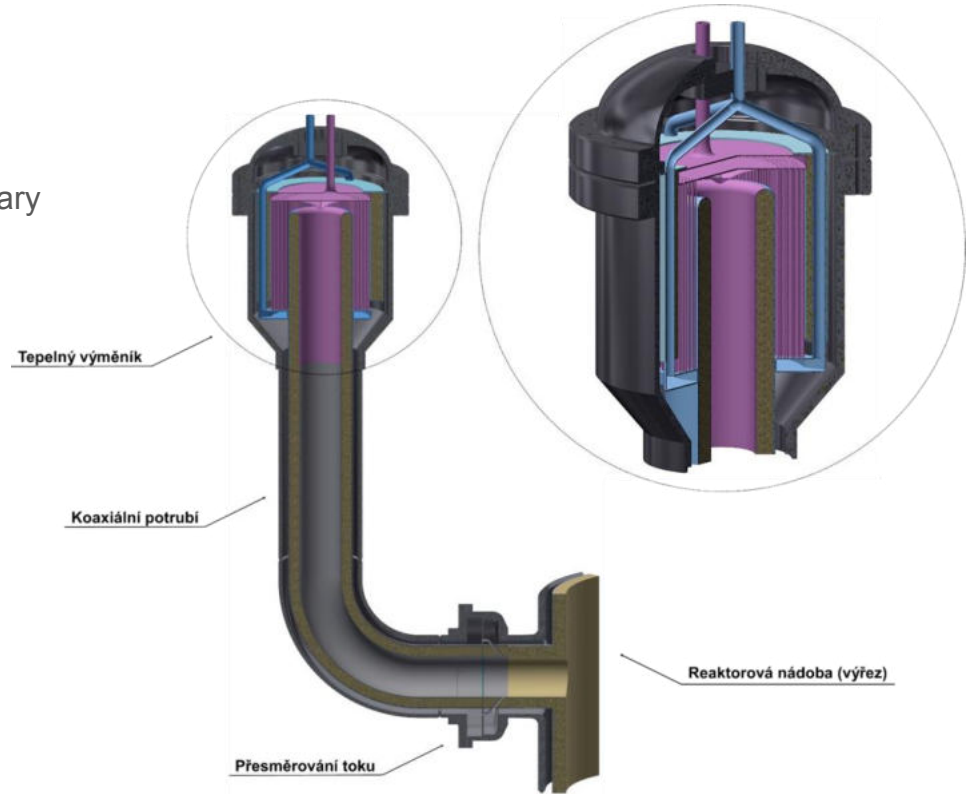

Decay heat removal system – secondary circuit

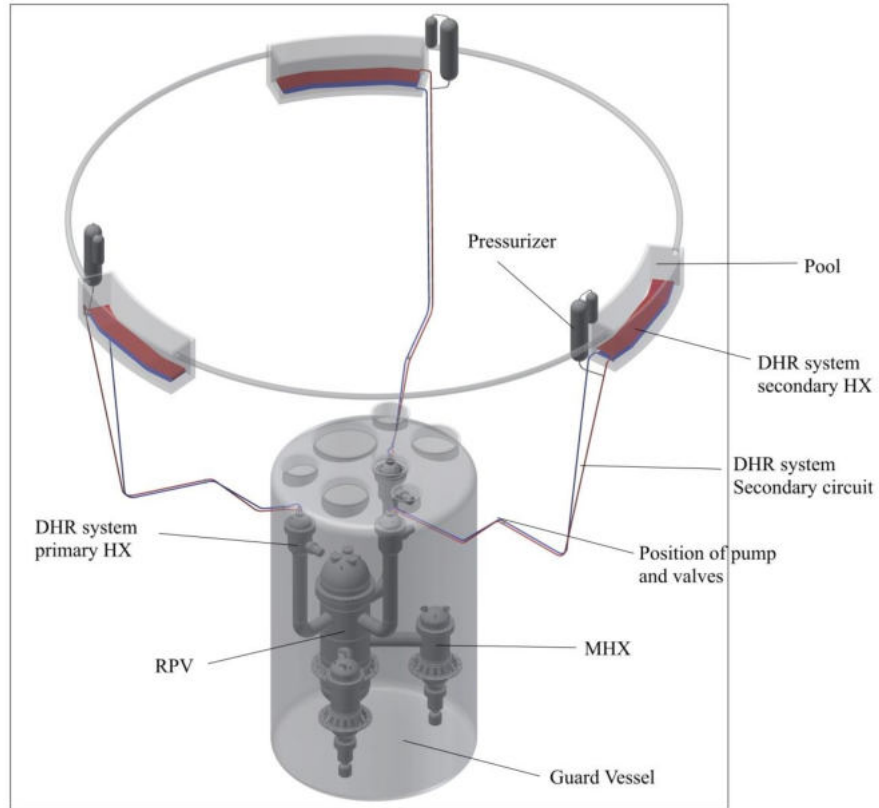

Emergency coolant injection system

- **Features:**
 - System of interconnected tanks with pressurized coolant connected to the RPV
 - Fully passive, actuated by pressure difference
 - During reactor operation – separated only by an overpressure membrane
 - If the primary pressure unexpectedly drops – the membrane is torn, and emergency coolant starts flowing into the primary circuit
 - Key safety system in LOCA



GFR safety – above and beyond

- **Goal - scenarios leading to core melting practically eliminated**
 - Seems achievable due to recent development
- **Practically eliminated ≠ physically impossible**
 - Since ALLEGRO will be the first of a kind prototype, precautions need to be taken
- **Residual risks elimination**
 - Implementation of a core catcher
 - Additional active DHR loop with battery-powered blower for low-pressure scenarios (large rupture of Guard Vessel)

Design of the core catcher

- **Main features**
 - Octagonal shape, only the bottom cooled
 - Made from steel blocks with fins
 - Copper plate for more even heat distribution
 - Water flowing in channels between the fins

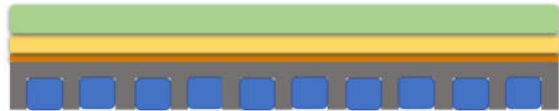

- Sacrificial material
- Refractory layer
- Copper plate
- Steel CC blocks
- water

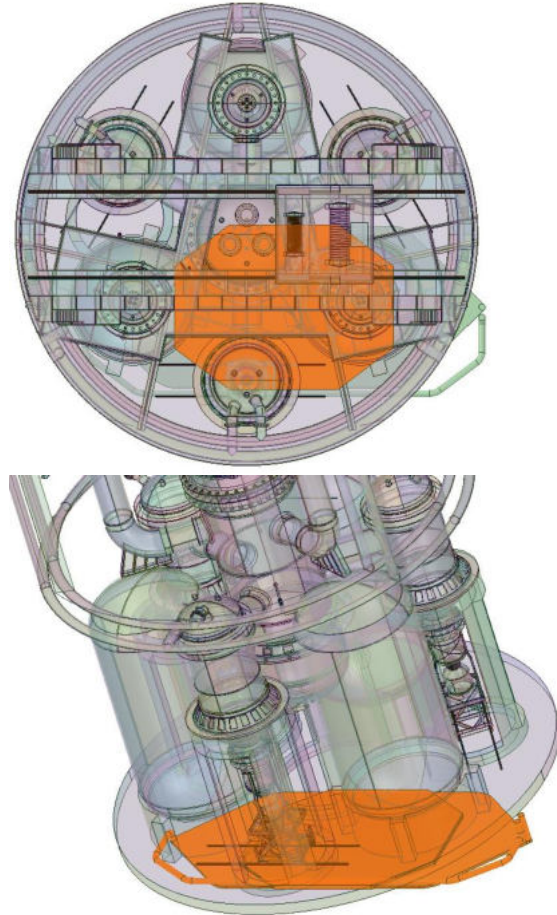

Design of the core catcher (2) – overall layout

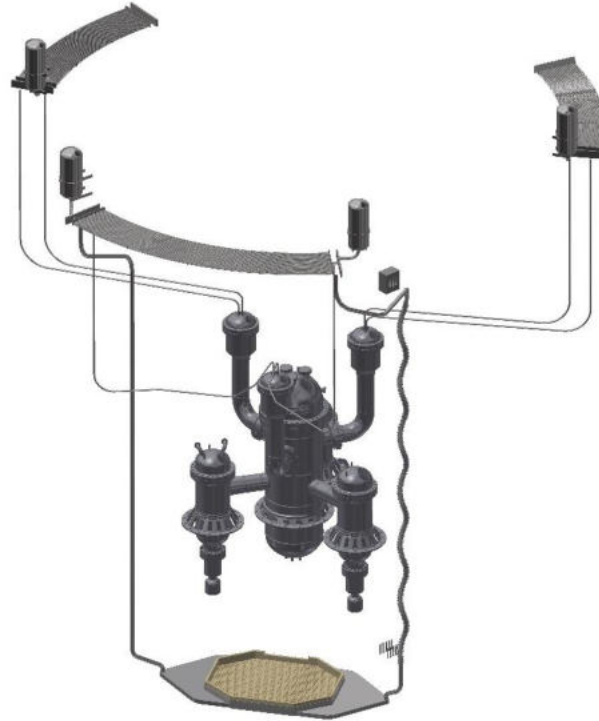
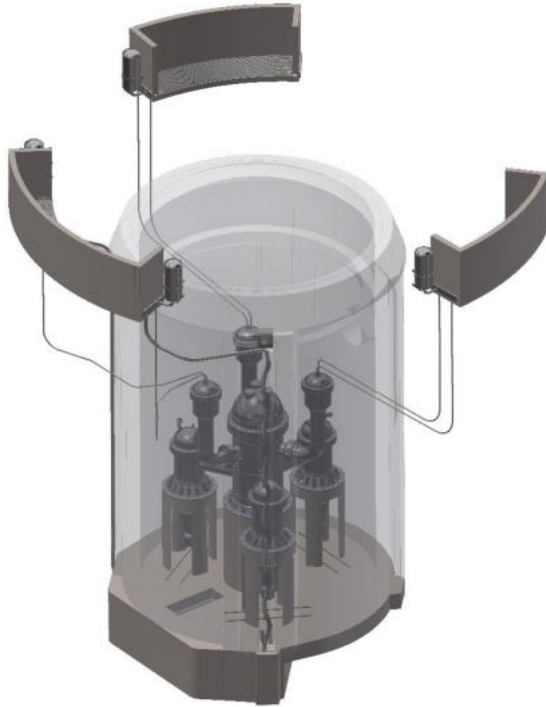

Thank you for your attention!



Development of KAIST–MMR

Jeong Ik Lee

KAIST

Nuclear & Quantum Engineering

jeongiklee@kaist.ac.kr

MIT-GFR (~2008)

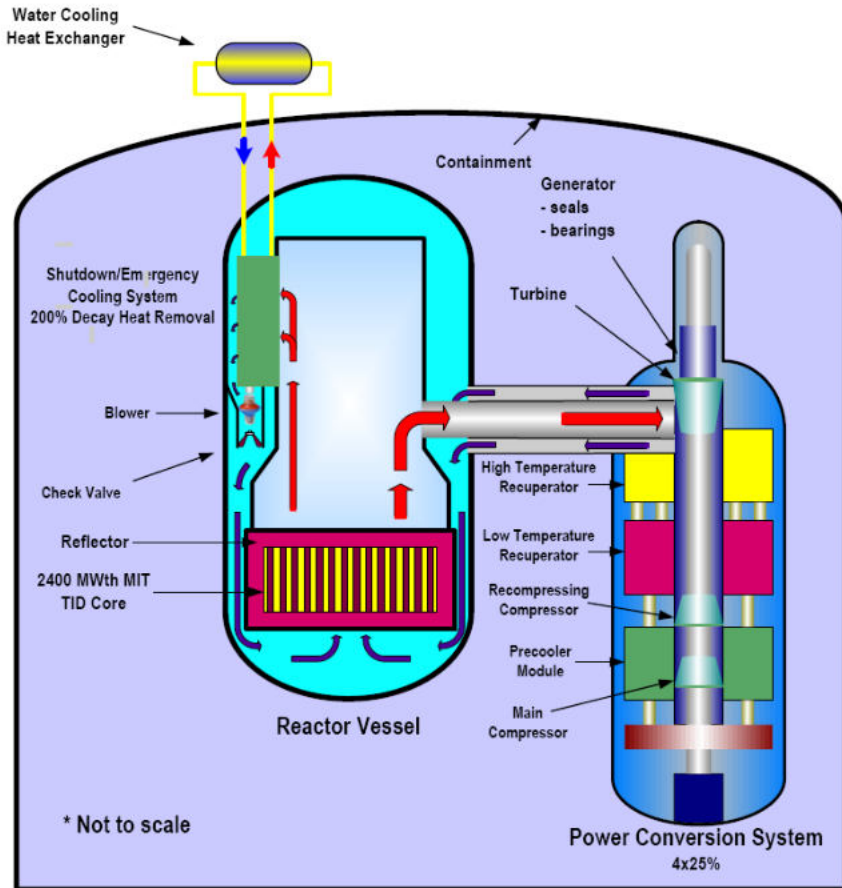

Parameter	Value
Core Thermal Output	2400 MW _{th}
Power Conversion System (PCS)	Brayton Recompression Cycle
Number of PCS loops	2
Plant Electrical Output	1130 MW _e
PCS Thermal/Net Efficiency	51/47
Primary to Secondary Plant Coupling	Direct
Primary Coolant/PCS Working Fluid	S-CO ₂
Core Inlet Temperature	485.5°C
Core Outlet Temperature	650°C
Peak Coolant Pressure	20 MPa
Plant Lifetime	60 years
Number of refueling cycles	3
Number of refueling batches	1
Decay Heat Removal (DHR) Capability	4x50% Shutdown Cooling Systems
DHR System Working Fluid	CO ₂ (reactor side) H ₂ O (ultimate heat sink side)

MIT-GFR (~2008)

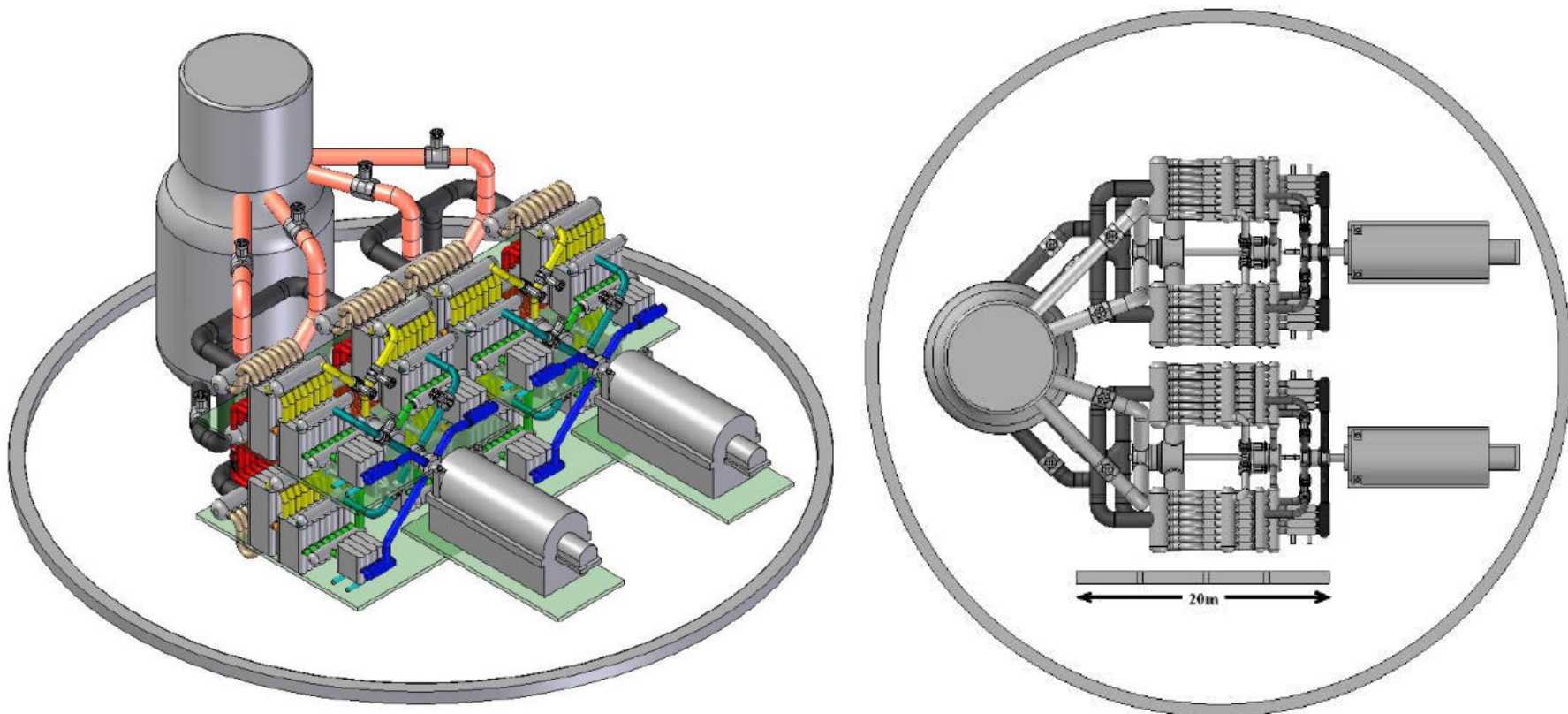

MIT-GFR (~2008)

Subsystem	Features	Comments
Core		
Fuel	UO ₂ + BeO	LWR TRU fissile ± MA
Clad	ODS-MA956, or HT-9	SiC a long range possibility
Configuration	tube-in-duct fuel assemblies, trefoil or "hexnut" pellets, vented, orificed	pin-type core as fallback is not up to task
Thermal-Hydraulics	axial peaking factor ≤1.3 radial peaking factor ≤1.2 power density ~ 85 W/cc	Vary BeO fraction to flatten power. Lower than GA GCFR of 1970's @ 235 W/cc
Burnup	≥120 MWd/kg (avg)	In single batch no-resuffle core, 17-yr lifetime
Safety Systems		
Aux. Loops	combined shutdown & emergency, 4 x 50% capable, active forced convection; but passive natural convection supplemented; water boiler heat sink	Based on RELAP parallel loop calculations. For P≥0.7 MPa natural convection alone may suffice
Emergency Power	Fuel cells to supplement diesels	Projected to be more reliable than diesels alone in long run
Plant		
Power Conversion System (PCS)	supercritical CO ₂ Brayton direct 2 x 600 MWe loops=1200MWe; 650°C core exit/turbine inlet, pressure: 20 MPa	AGRs in UK use CO ₂ coolant at 4 MPa and have T~650°C
Reactor Vessel	PCTV (prestressed cast iron reactor vessel)	Vessel houses loop isolation and check valves plus shutdown cooling heat exchangers
Containment	PWR type, steel liner reinforced concrete 0.7 MPa design capability 70,000 m ³ free volume filtered/vented	Internally insulated and CO ₂ can be added to keep pressure up to natural convection needs
H ₂ production by steam electrolysis (optional)	Separate water boiler loops (4) @ 10% of reactor power Recuperation of H ₂ & O ₂ heat allows cell operation at 850°C	Water boiler loops can also serve for self-powered decay heat removal

Aspect	S-CO ₂ GFR	SFR
Core		
Power Density, kW/l Fuel Materials Burnup (HM, TRU, MA)	Moderate (~100) UO ₂ Slower rate	High (~300) UO ₂ , UC, UN, UZr Comparable MWd/MT but faster rate A bit lower
Conversion (Breeding) Ratio	High	
Primary System		
Pressure Power Consumed to circulate coolant Natural Convection (hence "passivity") Chemical Reactivity of Coolant Inspectability	High: 20 MPa High Weak Low Transparent coolant	Low: 0.3 MPa Low Strong High (with air, H ₂ O) Opaque coolant
Power Conversion		
Cycles:	Direct Brayton Indirect Brayton Indirect Rankine Higher if direct Lower if direct	-- Indirect* Brayton Indirect* Rankine Indirect is comparable Indirect is comparable *(plus intermediate loop)
Efficiency: BOP cost:		
Containment		
	EPR type: ~ 7 atm	Lower Pressure: ≤ 2 atm
Upside Potential		
	Higher temperature, efficiency, breeding ratio possible	Mature technology
Experience Base		
	Limited, none built demo unit needed	Widespread, many built. can forego demo

MIT-GFR (~2008)

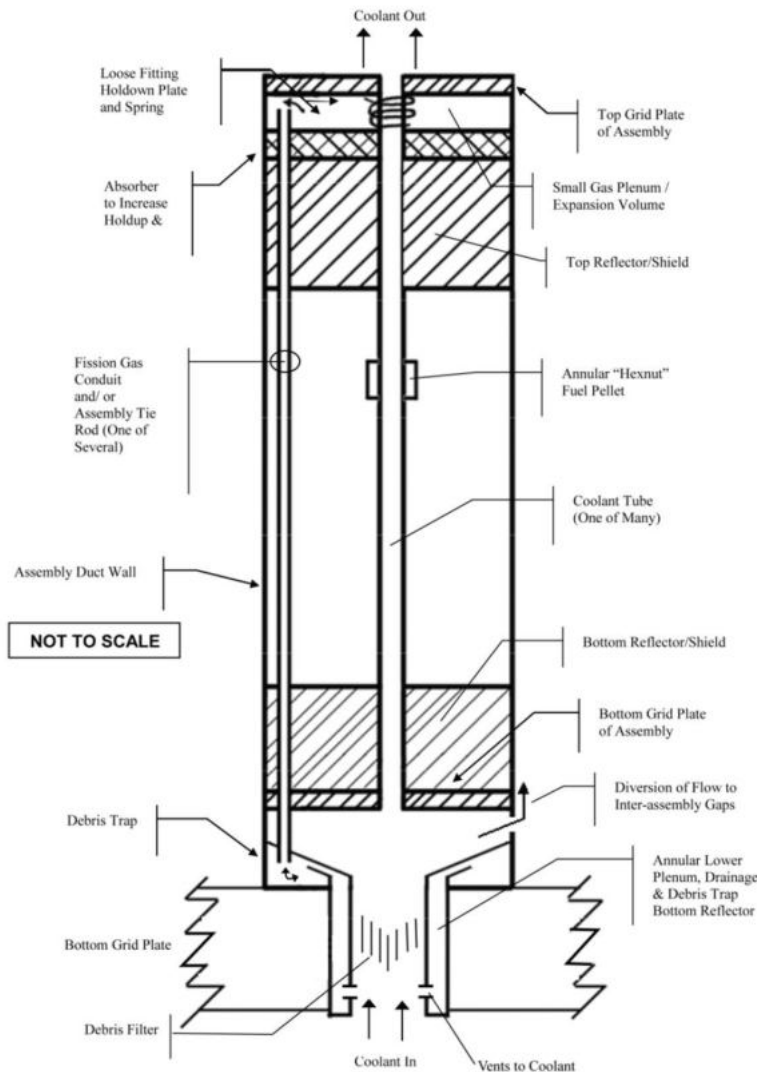

<Vented Fuel>

Parameter	Value
Whole Core Parameters	
Thermal Power	2400 MW _{th}
Specific Power	20.7 kW/kg _{HM}
Power Density	85.4 kW/l
Number of fuel batches	1
Reactivity Limited Burnup	1 st cycle: 140 MWd/kg, 18.48 EFPY 2 nd cycle: 133 MWd/kg, 17.66 EFPY 3 rd cycle: 130 MWd/kg, 17.16 EFPY
System Pressure	20 MPa
Core Inlet Temperature	485.5°C
Core Outlet Temperature	650°C
Active Core Height	1.54 m
Effective Core Diameter	4.81 m
H/D (active core)	0.32
Reflector	S-CO ₂ (radial), Ti (axial)
Shielding (radial and axial)	99 w/o B ₄ C
Fuel Assembly Parameters	
Fuel Assembly Description	Tube-in-Duct (TID)
Number of fuel assemblies	372
Number of control assemblies	19
Fuel TRU concentration	16.6% TRU (1 st cycle)
Assembly inner can flat-to-flat distance	22.32 cm (cold), 22.49 cm (hot)
Assembly outer can thickness	0.2 cm (cold), 0.2015 cm (hot)
Inter-Assembly gap size	0.28 cm (cold), 0.111 (hot)
Cladding thickness	0.07 cm
Coolant hole diameter	0.7 cm
Fuel, volume %	(U-TRU-Be)O ₂ , 59
Cladding, volume %	ODS MA956, 14
Coolant, volume %	S-CO ₂ , 27
Peak fluence	3.8 x 10 ²³ n/cm ²

MIT-GFR (~2008)

Table 1.6: Comparison of Key Neutronic Performance Criteria for the TID and Pin-Type Cores

	TID Core	Pin Core	1 m taller Pin Core
Reactivity Limited Burnup (MWd/kg)	140	61.6	80
Reactivity Limited Lifetime (EFPY)	18.48	6.24	13.39
Specific Power (kW/kg _{HM})	20.7	27.02	16.35
Heavy Metal Loading (kg _{HM})	115942	88823	146767
Reactivity Swing (pcm)	3726	2017	2312
Diluent (BeO) Zoning (% BeO)	30/33/00	38/40/00	38/40/00
Core Average BeO (volume %)	21	26.1	26.1
Enrichment Zoning (% TRU)	16.6/16.6/16.4	19.85/19.85/19.85	18.69/18.69/19.1
Core Average Enrichment (% TRU)	16.53	19.85	18.83
Coolant Volume Fraction (unit cell)	25	35	35
Maximum Rodded CVR (¢) (EOL)	-36±5 (EOL)	-37±5 (EOL)	-2±4 (EOL)

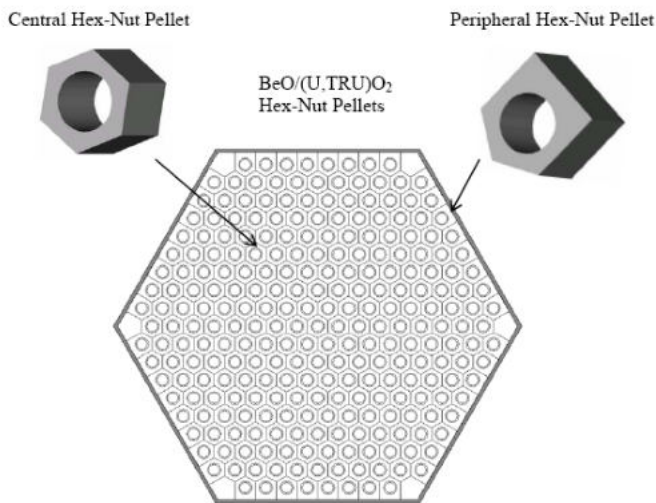

<Tube-In-Duct Fuel>

MIT-GFR (~2008)

- Supercritical CO₂ cooled power cycle
 - High cycle efficiency in moderate temperature ranges (400°C~700°C).
 - Applicable to Generation IV nuclear systems
 - Compact component size → Better modularization.
 - Cheap and abundant coolant

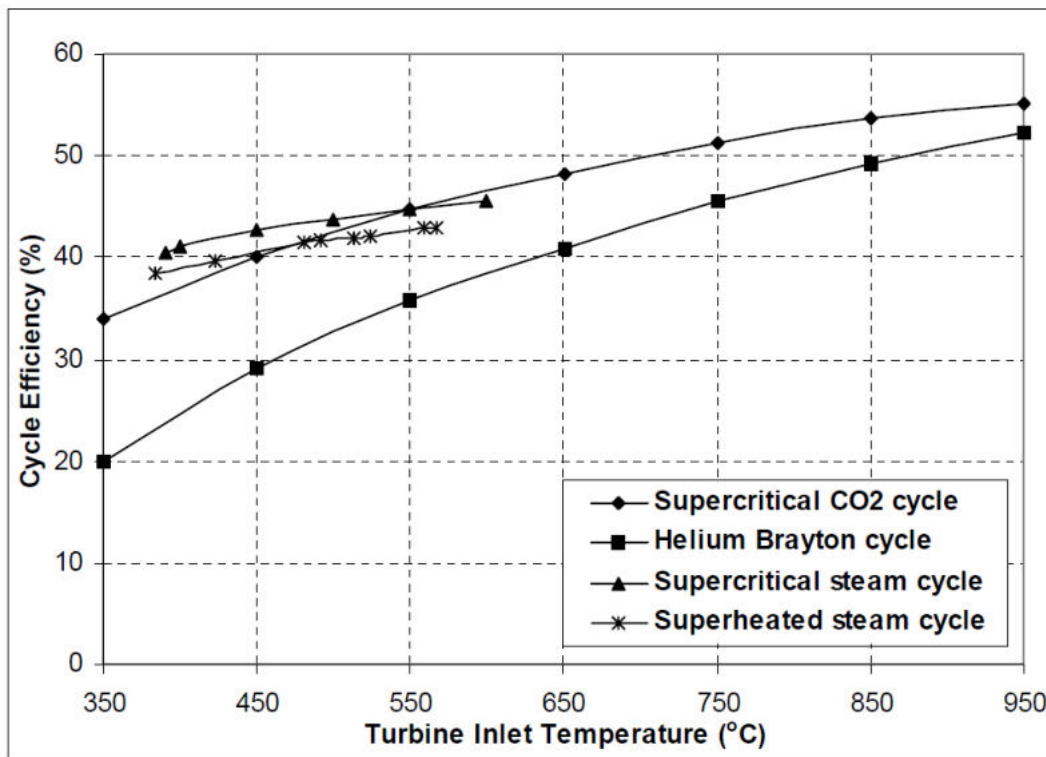

Single Block dimensions

- » Length: 1.5 m
- » Width: 0.6 m
- » Stack height: 0.6 m

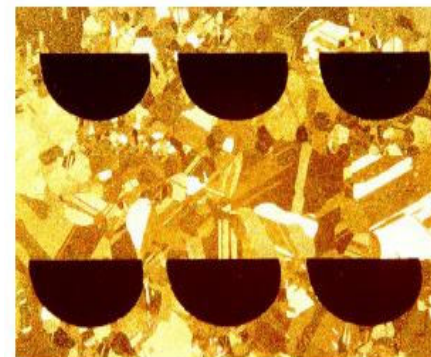
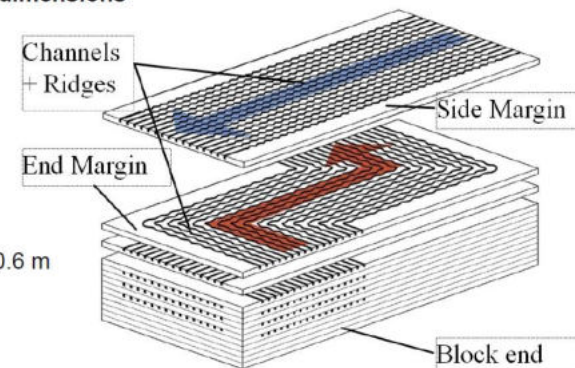

MIT-GFR (~2008)

- Supercritical CO₂ cooled power cycle
 - High cycle efficiency in moderate temperature ranges (400°C~700°C).
 - Applicable to Generation IV nuclear systems
 - Compact component size → Better modularization.
 - Cheap and abundant coolant

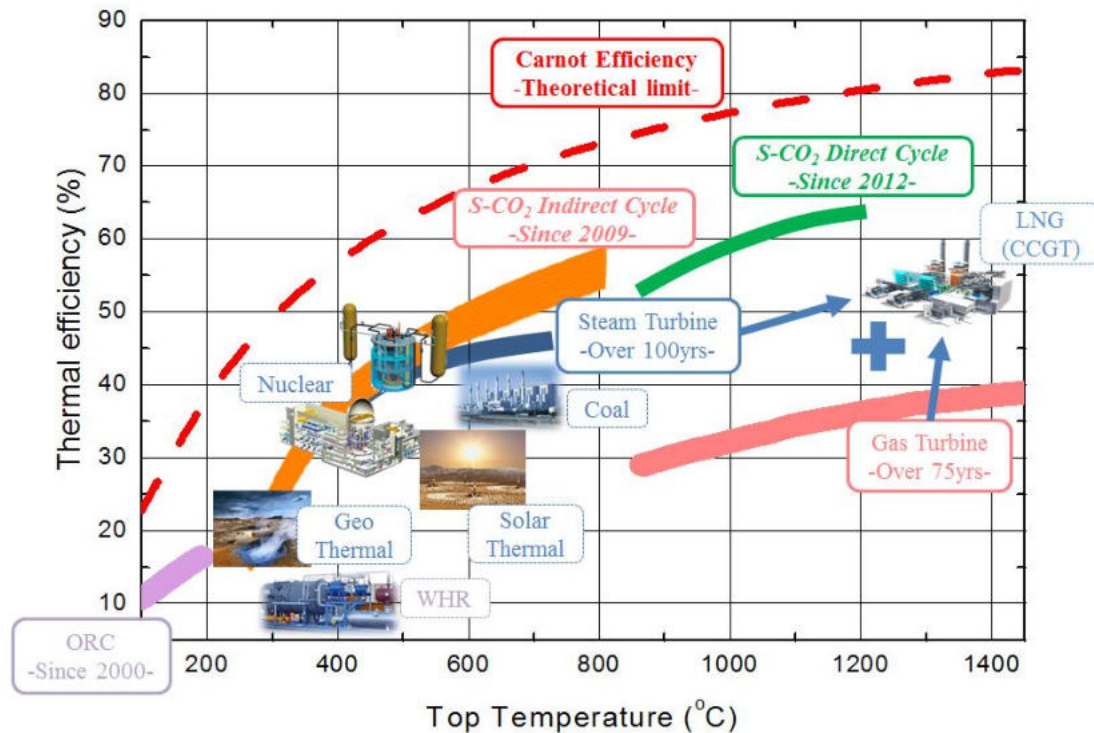
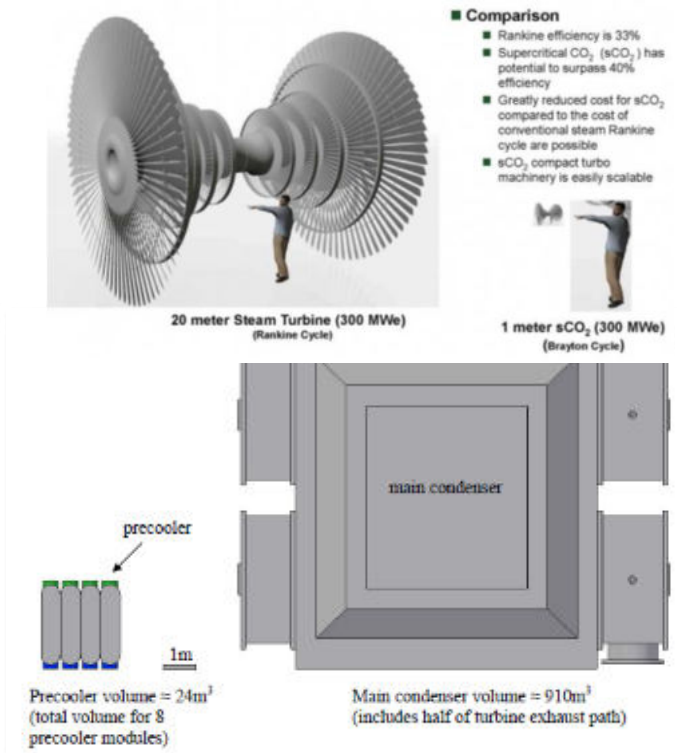

MIT-GFR (~2008)

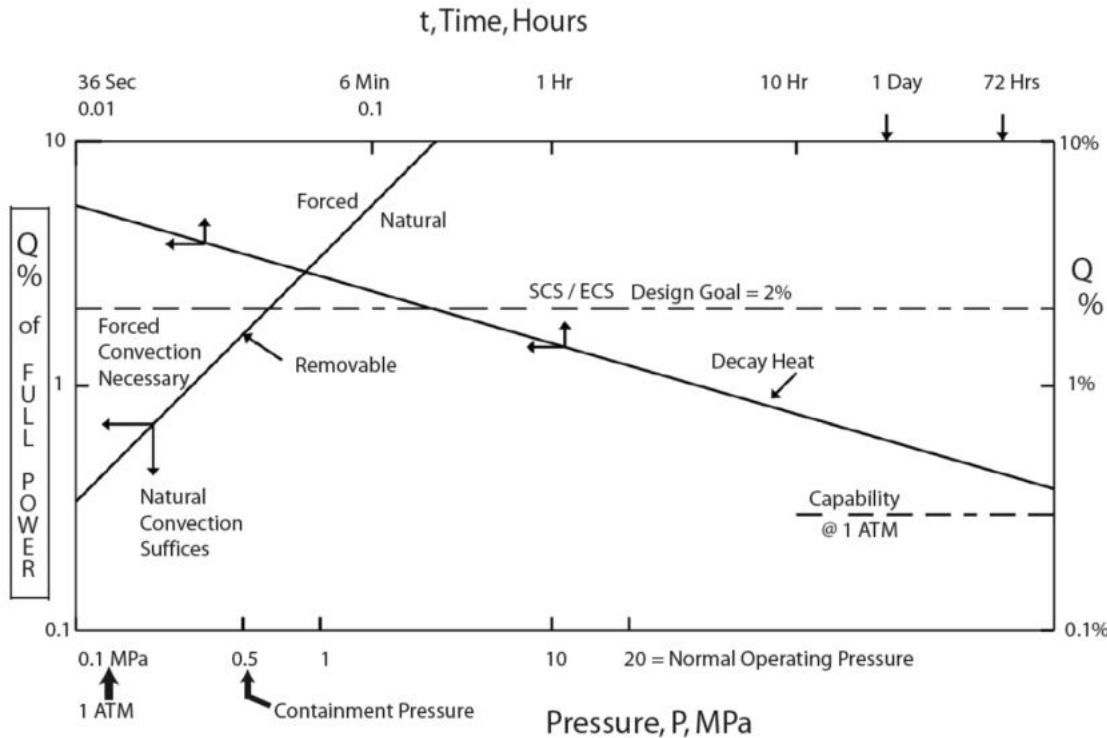

Removable by Natural Convection: $Q = C \cdot P^{1.0}$, ($C = \text{System - Specific Parameter} \approx 3\%$)

Decay Heat Generation: $Q = \frac{0.0147}{t^{0.28}}$, (t in hours)

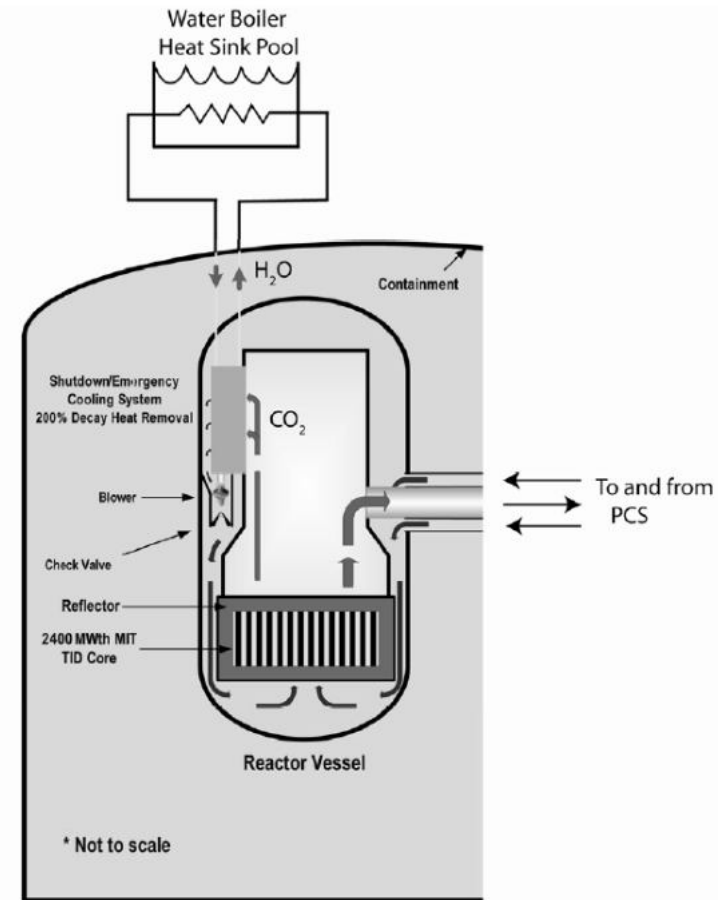
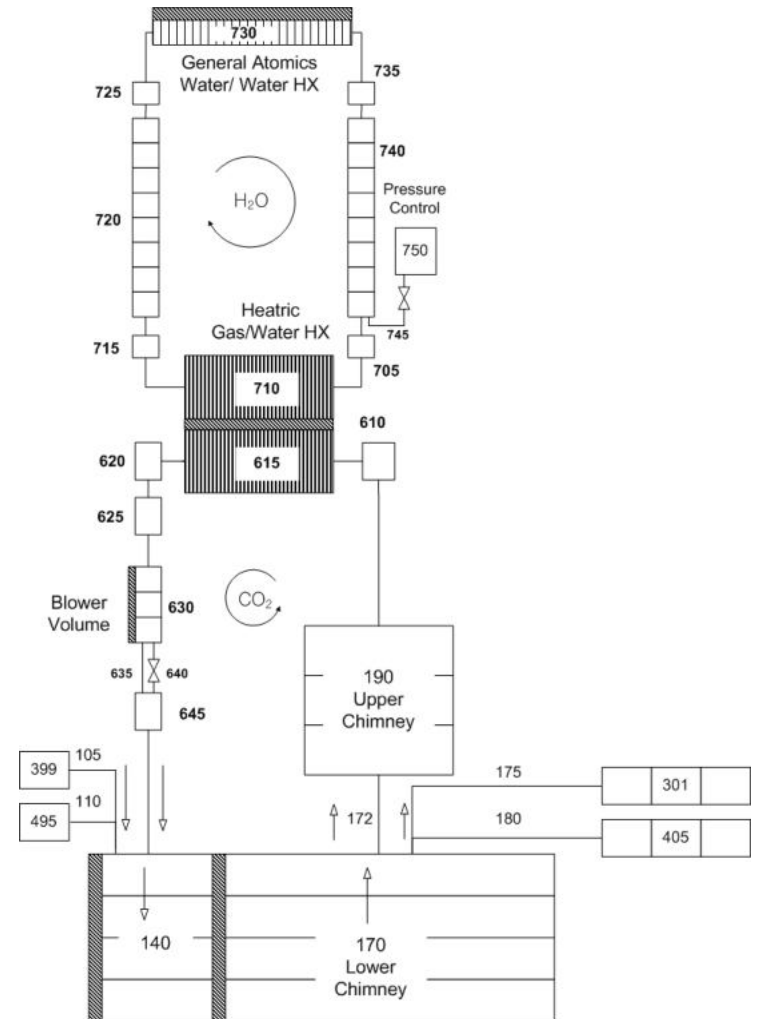
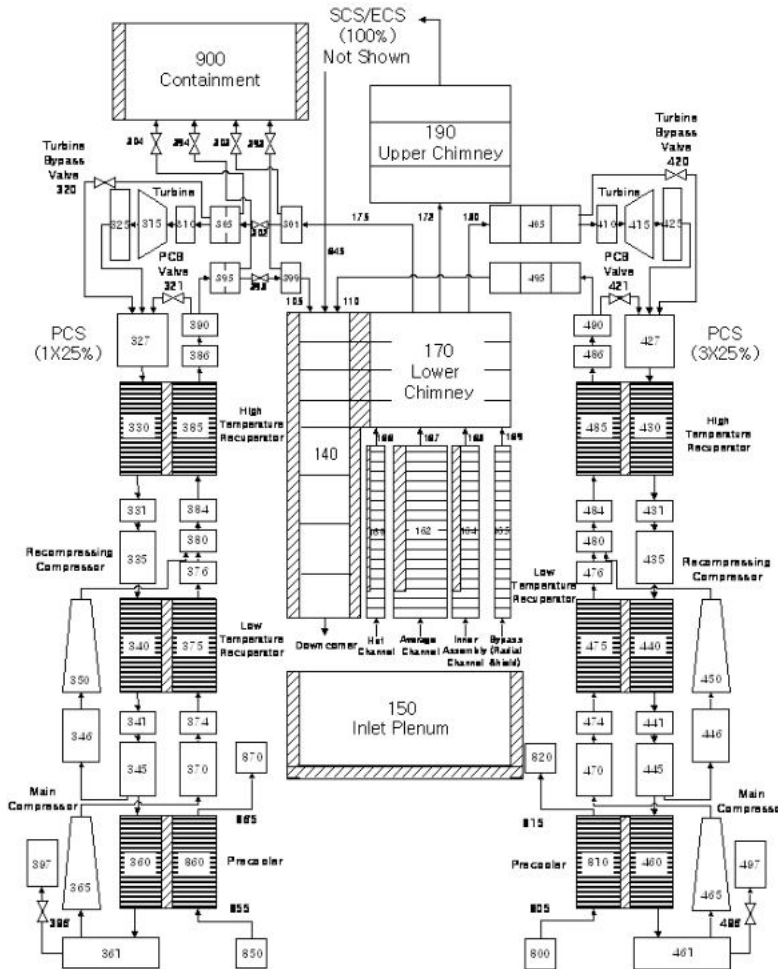

Fig. 2.1: Map of Shutdown Cooling Operating Regimes

MIT-GFR (~2008)

RELAP5 Model of MIT GFR



MIT-GFR (~2008)

- RELAP5 Results of MIT GFR
 - ▣ Motor valve engagement necessary
 - ▣ Blower operation necessary

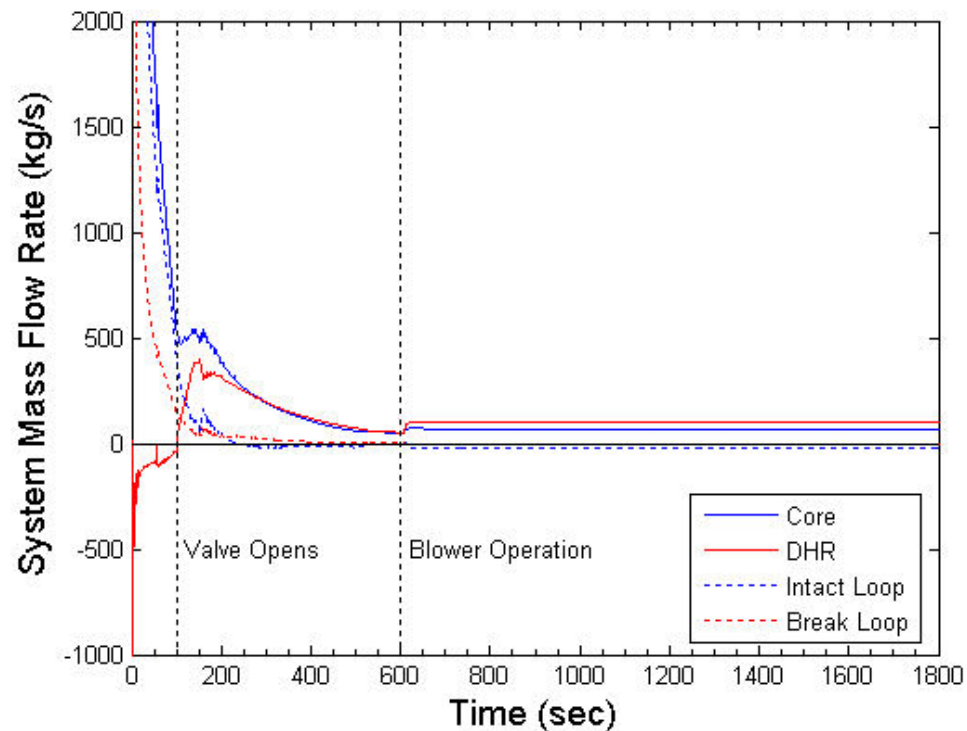
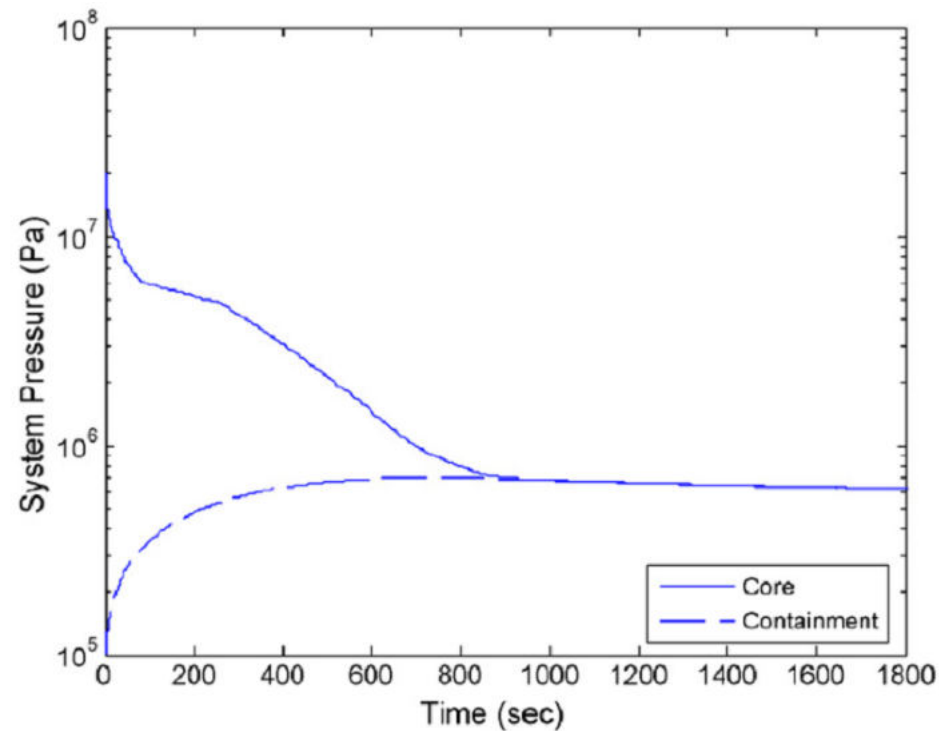

MIT-GFR (~2008)

- RELAP5 Results of MIT GFR
 - ▣ Uncertainties in Heat Transfer

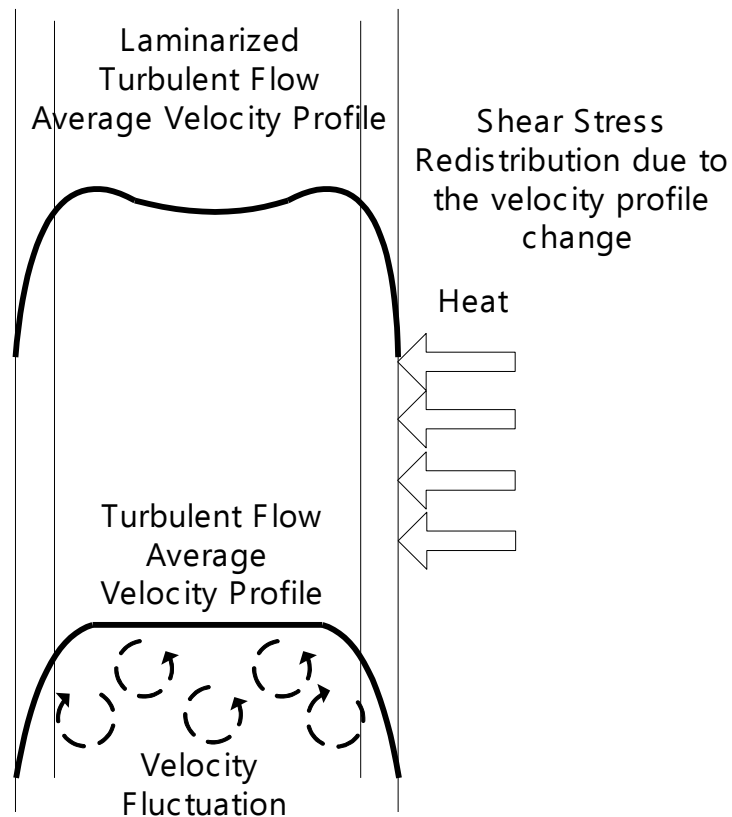
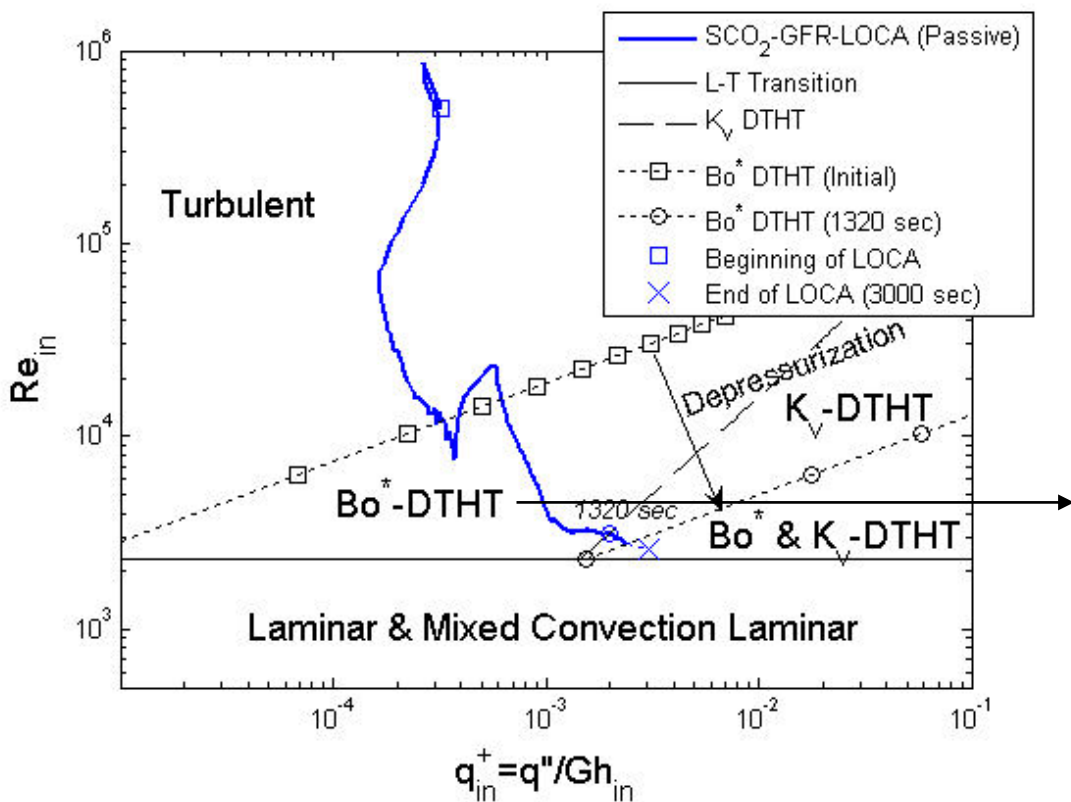

Hall & Jackson (1969)

MIT-GFR (~2008)

Experiments to Resolve Uncertainties

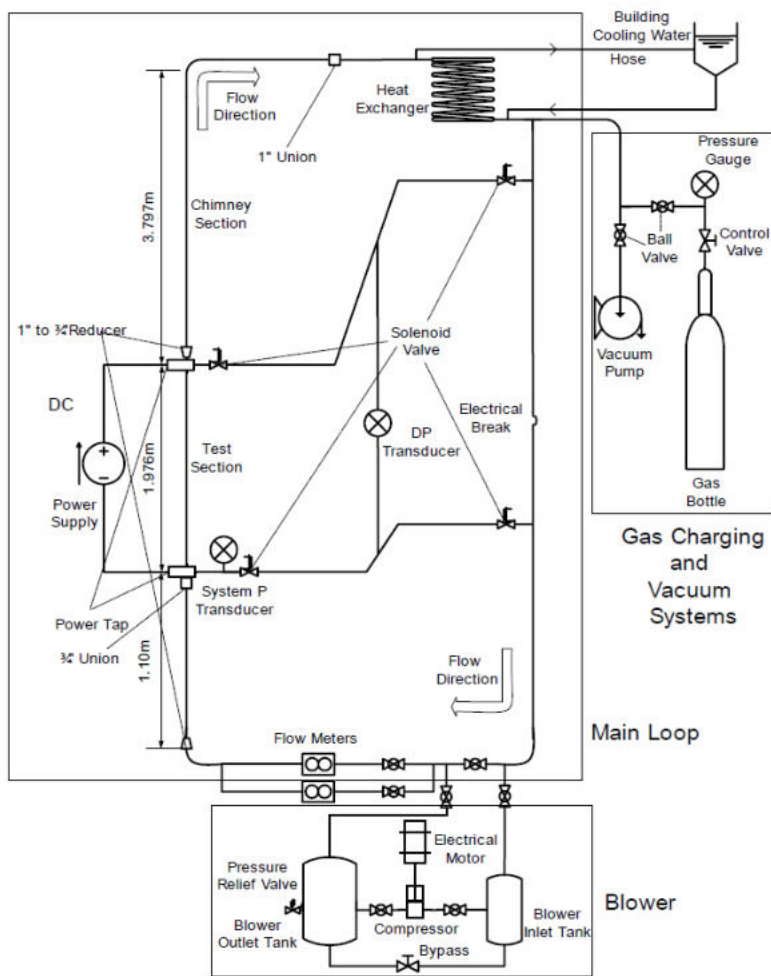

If $K_{v,m} < 2.5 \times 10^{-6}$, $Bo_m^* < 2.0 \times 10^{-6}$ and $Re_m > 2300$ (Turbulent)

$$Nu_{\text{TYPE3}} = \frac{\left(\frac{f}{8}\right)(Re-1000)Pr \left(\frac{T_w}{T_b}\right)^{-0.5} \left(1 + \frac{x}{D}\right)^{-\frac{2}{3}}}{1 + 12.7\sqrt{\frac{f}{8}}(Pr^{2/3}-1)}$$

If $K_{v,m} \geq 2.5 \times 10^{-6}$ or $Bo_m^* \geq 2.0 \times 10^{-6}$ and $Re_m > 2300$ (DTHT)

$$Nu_{\text{TYPE3-temp}} = \frac{\left(\frac{f}{8}\right)\left(Re - 0.011\left(\frac{q^*}{Re^{0.44}}\right)^{-1.16}\right)Pr \left(\frac{T_w}{T_b}\right)^{-0.5} \left(1 + \frac{x}{D}\right)^{-\frac{2}{3}}}{1 + 12.7\sqrt{\frac{f}{8}}(Pr^{2/3}-1)}$$

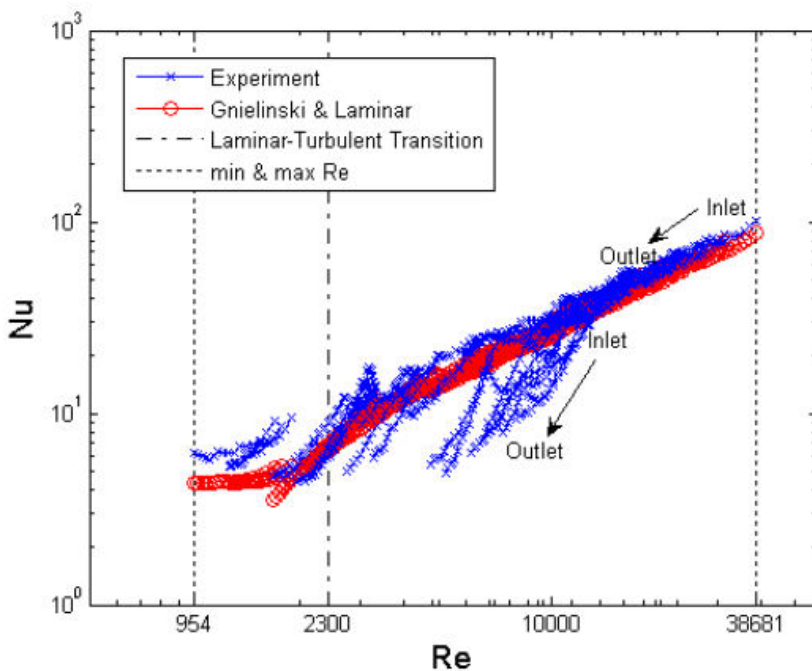

MIT-GFR (~2008)

- **Issues with MIT-GFR**
 - ▣ **Had to go large power due to economy and meeting GEN-IV goal**
 - ▣ **High pressure system**
 - ▣ **Very challenging to go for passive decay heat removal system**
 - ▣ **Requires high back pressure if LOCA occurs in order to have moderate coolant heat transfer**
 - ▣ **Had many issues with heat transfer uncertainties when natural circulation is used**

KAIST-MMR V1.0

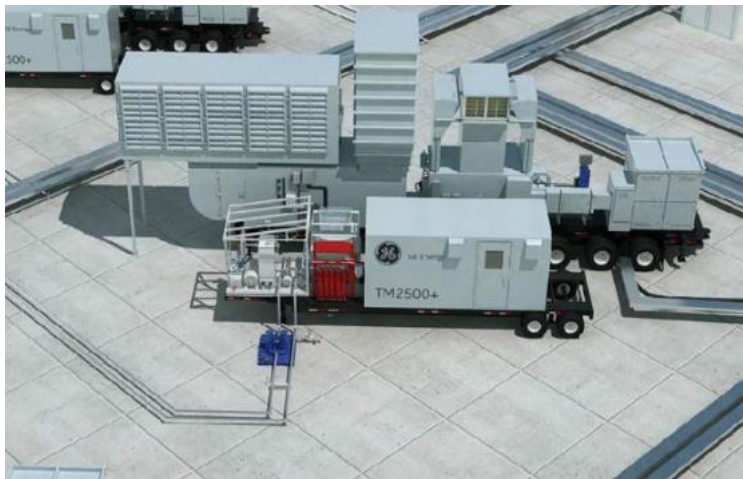

<TM2500+, Mobile Gas Turbine Generator, General Electric>

12 modules, 45 MWe each produces 540 MWe



Cross-sectional View of Reactor Building

<NuScale>

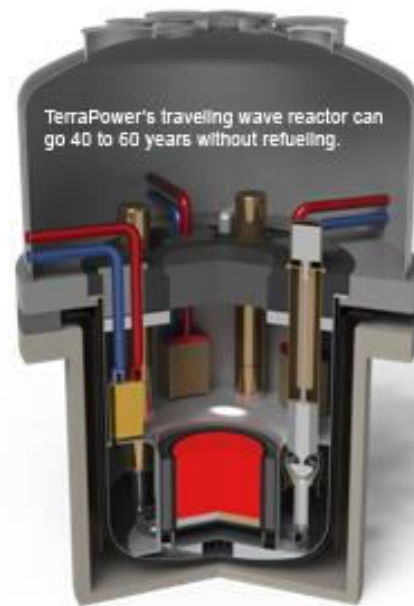

TerraPower's traveling wave reactor can go 40 to 60 years without refueling.

<TWR>

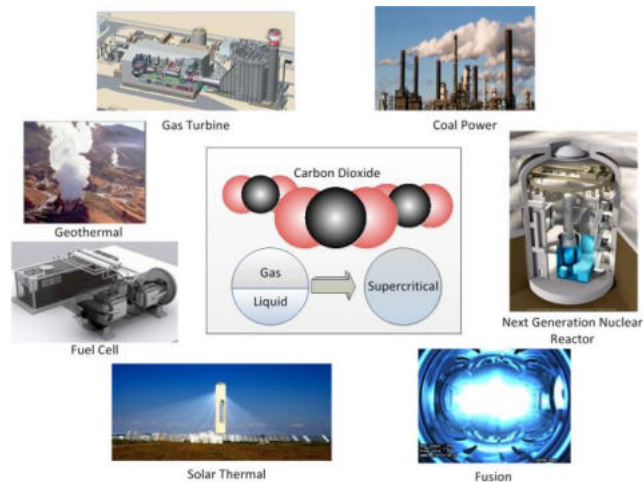

<S-CO₂ Cycle>

KAIST-MMR V1.0 (~2012)

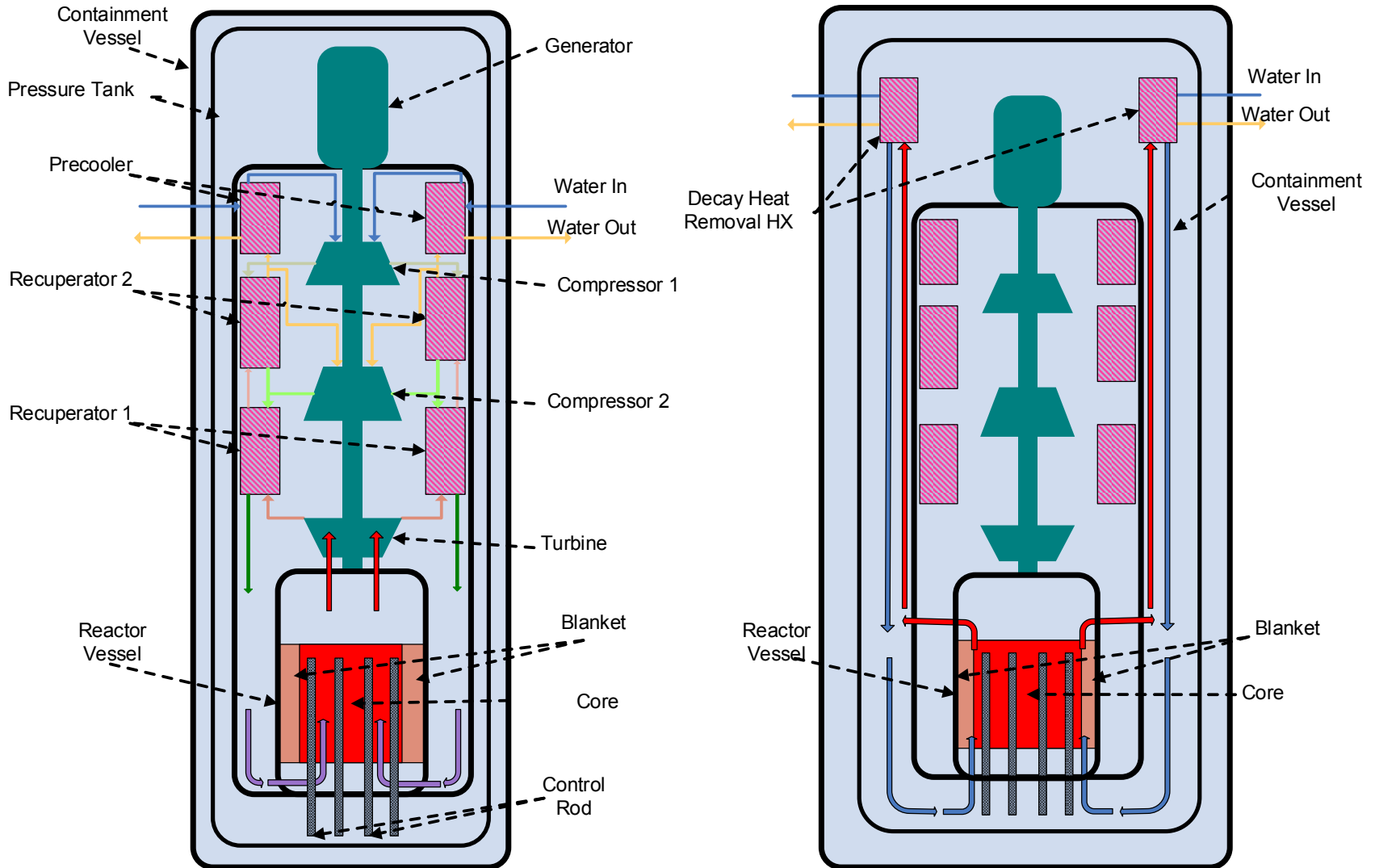

KAIST-MMR V1.0 (~2012)

Core lifetime

- ▣ To increase the core lifetime, N-15 is used instead of N-14 in the UN fuel.
 - N-15 has lower absorption cross section at high neutron energy range.
- ▣ To reduce the coolant void reactivity, O-17 is used instead of O-16 in the UO₂ fuel.
 - O-17 provides negative feedback when the neutron spectrum hardens.
- ▣ LME radial reflector is important to maintain the neutron economy.

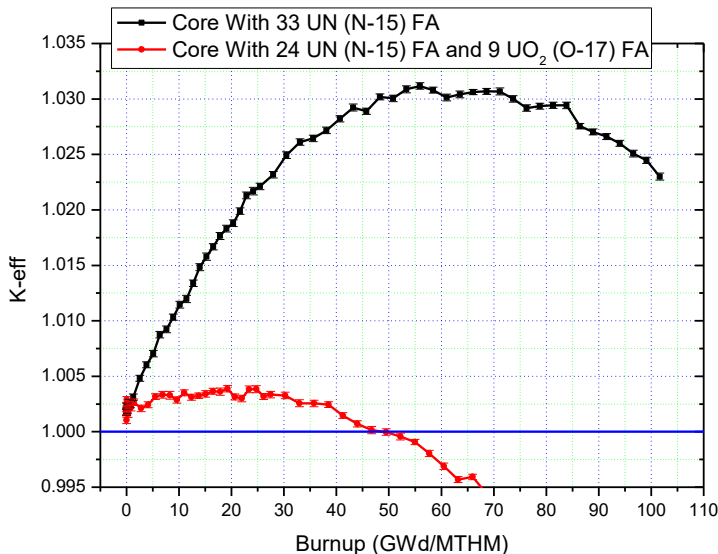

Type of core	Enrichment	Discharge BU [GWd/MTHM]	Lifetime [Years]
UN	10.75%	> 100	>100
Mix UN + UO ₂	12.05%	46.72	49.3

Type of core	Coolant void reactivity at EOC
UN	17.726 ± 4.516 ϕ *
Mix UN + UO ₂	-25.633 ± 4.321 ϕ

*At 101.65 GWd/MTHM

KAIST-MMR V1.0 (~2012)

	Fuel Assembly		Radial Reflector	Shield
Material	UO ₂	UN	99.75% Pb- 2.5%Mg (LME)	B ₄ C
Cladding	HT9	HT9	HT9	HT9
Density (g/cc)	10.41	13.371	9.466	2.385
Number of pins	127	127	91	91
Pin Diameter	1.90 cm	1.90 cm	2.10 cm	2.10 cm
Fuel Radius	0.89 cm	0.89 cm	0.95 cm	0.95 cm
Gap Thickness	0.01 cm	0.01 cm	-	-
Cladding Thickness	0.05 cm	0.05 cm	0.10 cm	0.10 cm
Duct Thickness	0.3 cm	0.3 cm	0.3 cm	0.3 cm
Inter-assembly Gap	0.25 cm	0.25 cm	0.25 cm	0.25 cm
P/D	1.13	1.13	1.01	1.01
Assembly Pitch	25.276 cm	25.276 cm	25.276 cm	25.276 cm
Flat to Flat Distance	25.026 cm	25.026 cm	25.026 cm	25.026 cm
Fuel/reflector volume fraction	56.265%	56.265%	65.065%	65.065%
Gap volume fraction	1.271%	1.271%	-	-
Coolant volume fraction	30.265%	30.265%	15.024%	15.024%
Structure volume fraction	12.198%	12.198%	19.911%	19.911%

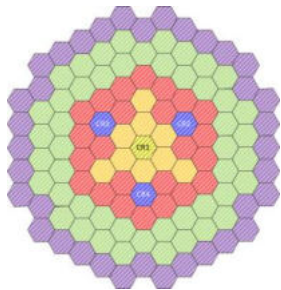
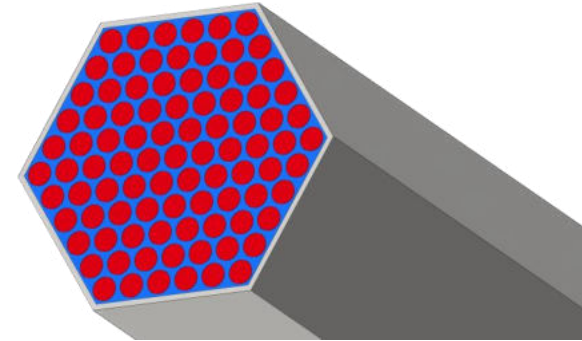

- UO₂ Fuel Assembly (9)
- UN Fuel Assembly (24)
- Reflector Assembly
- Primary Control Assembly
- Secondary Control Assembly
- Shielding Assembly

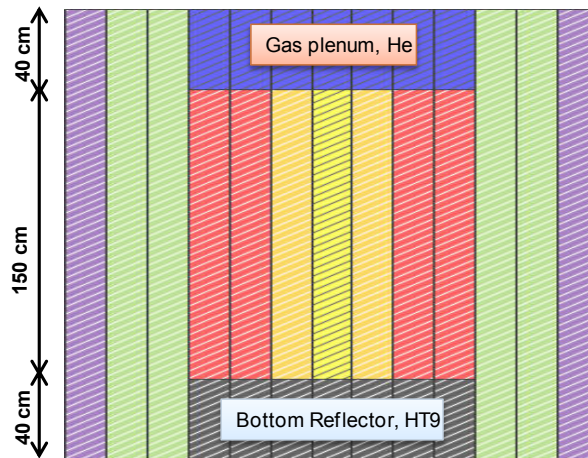

Reactor power	50 MWth
Number of FAs	33
Active core equivalent radius	88.47 cm
Active core height	150 cm
Coolant speed	5.23 m/s
Coolant pressure	15 MPa
Coolant inlet temperature	758.65 K
Coolant outlet temperature	923.15 K

KAIST-MMR V1.0 (~2012)

- **Design selection**
 - **Bearing system** : Gas foil bearing / Magnetic Bearing
 - **Cycle layout** : Simple recuperation Brayton cycle
 - **Turbine Inlet temperature** : 650 °C
 - **Target thermal Power** : 50 MWth
 - **Target mass flow rate** : 235.95 kg/s
- **Detailed cycle and turbomachinery conditions**
 - **Thermal efficiency** : 35 % (17.5MWe)
 - **Compressor, RPM** : 15000
 - **Compressor, Impeller outlet diameter** : 287 mm
 - **Turbine, RPM** : 15000
 - **Turbine, Impeller Inlet diameter** : 402 mm
 - **Total PCU Volume**: less than 2m³

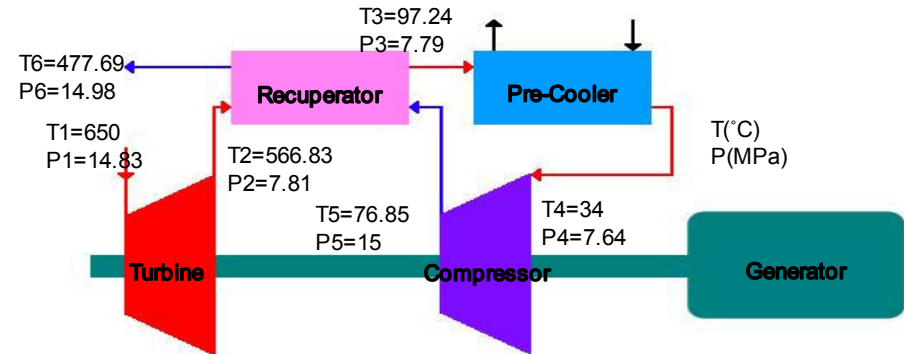
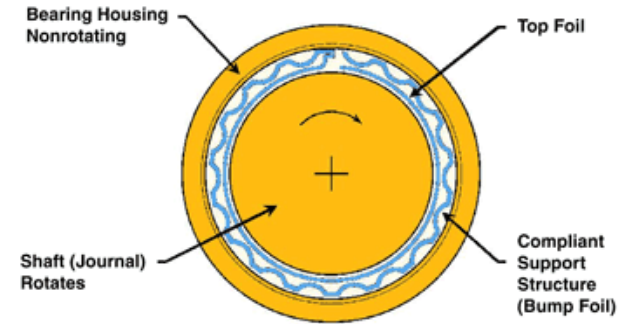

Thermal power dependence of turbomachinery design parameters

Thermal power	Mass flow rate	Compressor		Turbine	
		RPM	Diameter	RPM	Diameter
10	47.18	33500	128.35	33500	179.77
20	94.37	23700	181.51	23700	254.24
30	141.56	19300	222.3	19300	311.38
40	188.75	16700	256.7	16700	359.55
50	235.94	15000	287	15000	402
60	283.13	13600	314.39	13600	440.36
70	330.32	12600	339.58	12600	475.65
80	377.51	11800	363.02	11800	508.49
90	424.7	11100	385.05	11100	539.33

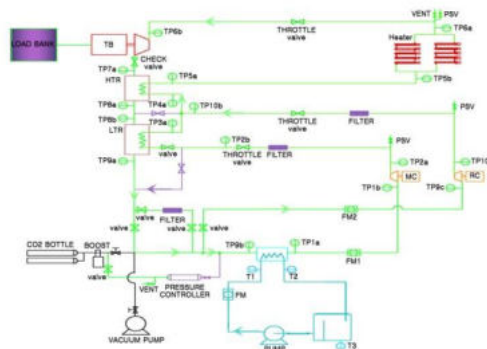

KAIST-MMR V2.0

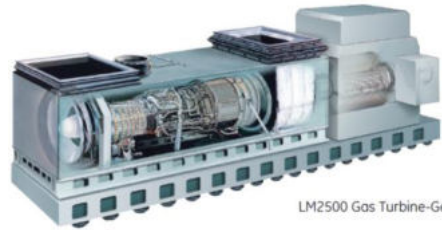

LM2500 Gas Turbine-Ge



<TM2500 – Mobile gas turbine generator, GE>

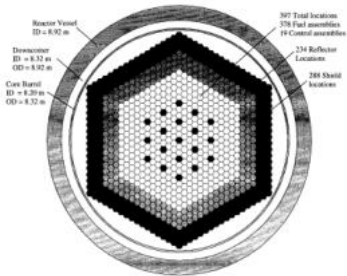
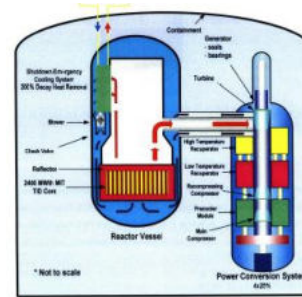

<S-CO₂ GFR, MIT, Michael A. Pope>

- 20-30MWe mobile gas turbine generator – **TM2500** (General Electric)
→ *Used for emergency, distributed power supply.*
- +
- Concept of **supercritical CO₂ Gas-cooled Fast Reactor (GFR)** - MIT
 - *Proposed a large S-CO₂ GFR (2400MWth) coupled to S-CO₂ Brayton cycle.*
 - *Performed Thermal-hydraulic studies.*



*KAIST Micro Modular Reactor (MMR)

- Transportable modular reactor.
- Supply of energy to remote region
- **Direct Supercritical CO₂-cooled** fast reactor.
- One module contains reactor core, power conversion system.
- **Long life core** without fuel reloading.
- Economic benefit by shop-fabrication.



<Micro Modular Reactor, KAIST, J.I Lee, Y.H Kim, Y.H Jeong>

KAIST-MMR V2.0

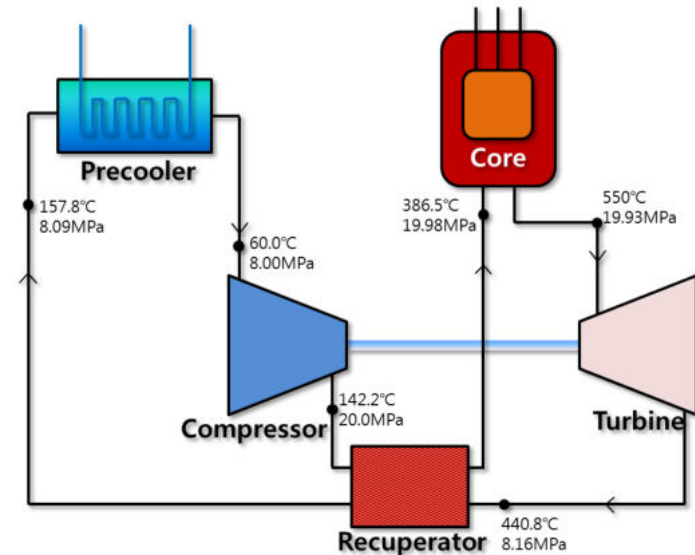
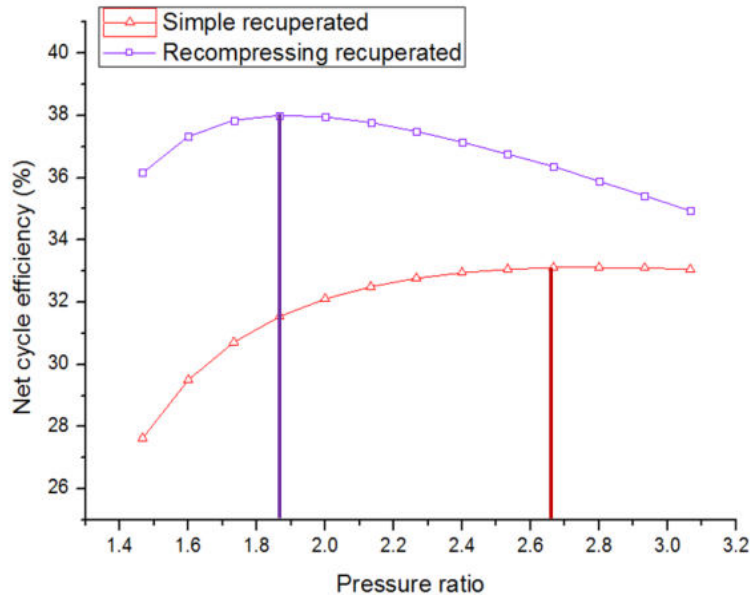
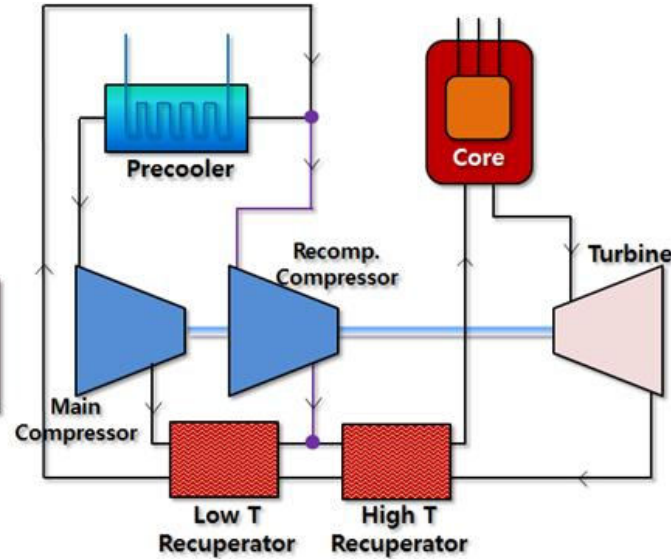
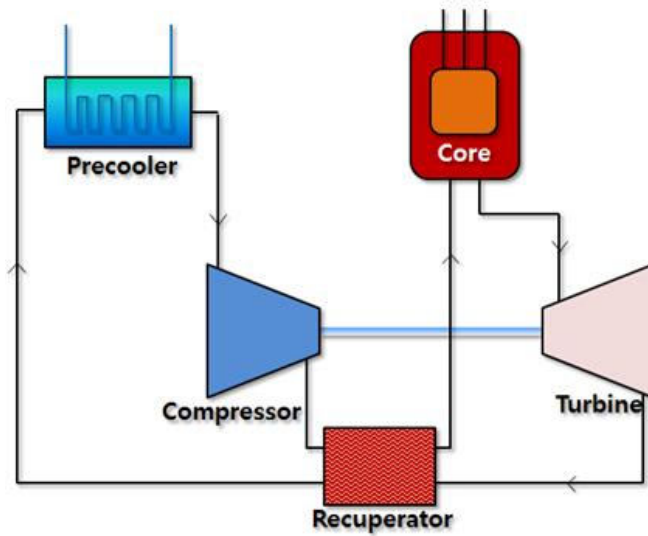

KAIST-MMR V2.0 (~2016)

- MMR should be operated at the region where limited number of operators stay
 - To minimize refueling, the reactor should have steady excess reactivity during the lifetime by introducing Robust Fuel Assembly.
 - To minimize active control of the reactor, the reactor has adequate negative temperature coefficient.
- UN and UC fuels were considered but UC fuel was selected ultimately due to better economy, since N-15 enrichment was necessary for UN fuel.

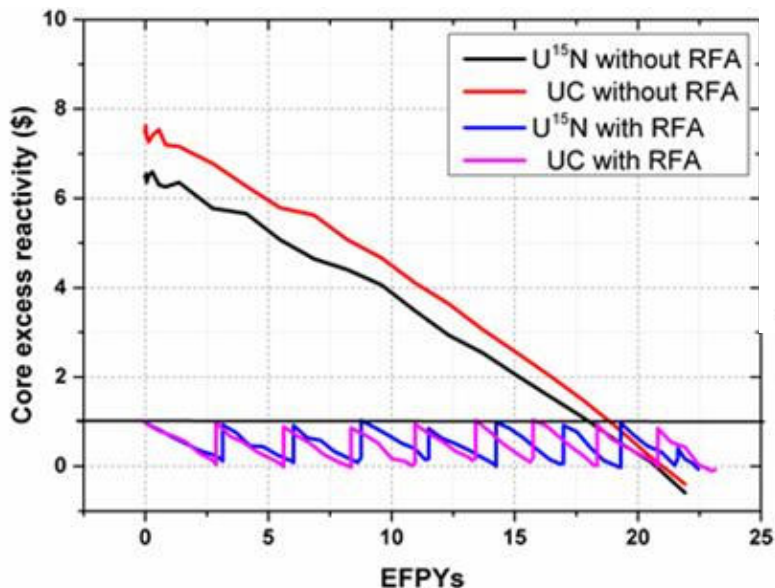

<Excess reactivity of MMR core>

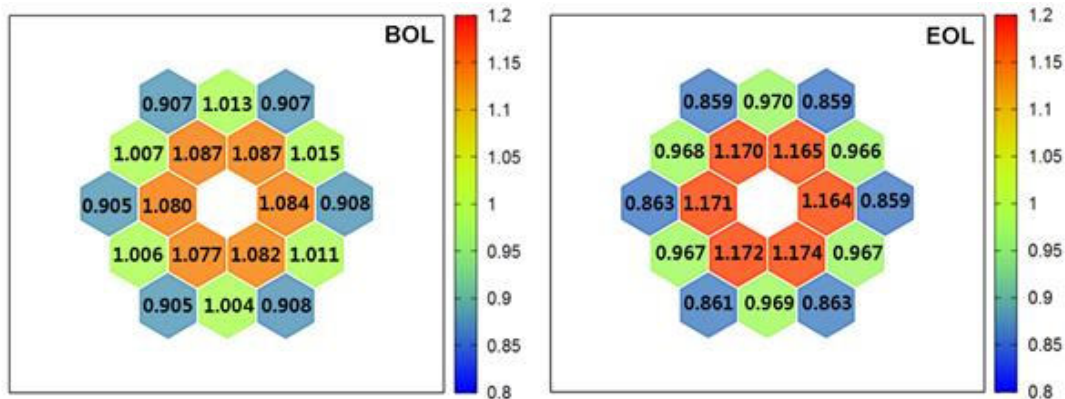

Condition	U ¹⁵ N core		UC core	
	FTC, pcm/K	CVR, pcm	FTC, pcm/K	CVR, pcm
BOL	-0.366±0.02	-234.801±16.1	-0.457±0.02	-234.470±16.8
EOL	-0.511±0.03	-287.762±17.0	-0.479±0.03	-352.614±17.0

KAIST-MMR V2.0 (~2016)

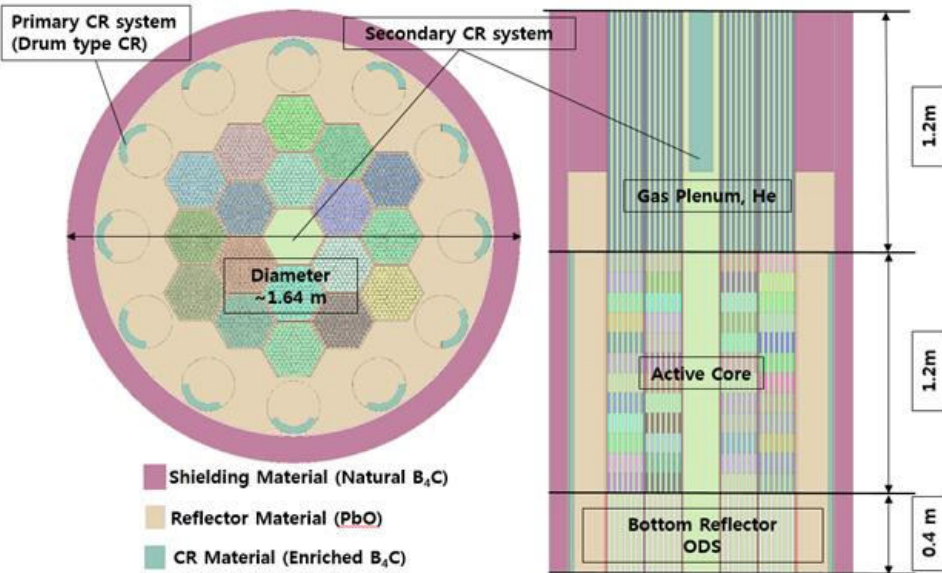

- The core is designed to have a 20-year lifetime (40~50MWd/kg) without refueling.
- The core size was minimized by adopting the drum-type reactivity control system.
- A replaceable fixed absorber (RFA) is introduced in a unique way to minimize the excess reactivity and power peaking factor of the core.

Reactor power	36.2 MWth
Life time of core	20 years
Active core equivalent radius	46.58 cm
Active core height	120 cm
Diameter	1.64m
Coolant pressure	20 Mpa
Coolant inlet temperature	382.2 °C
Coolant outlet temperature	550 °C
Mass of Core	39.6 ton

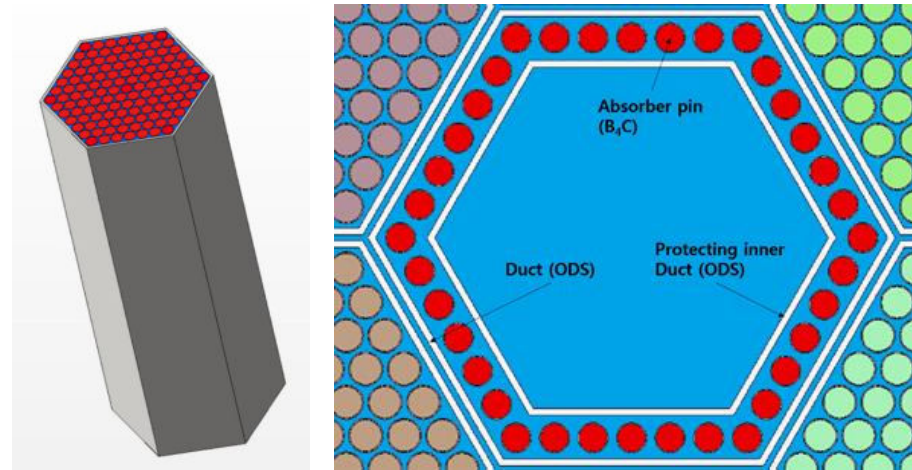

Fuel material : UC
Cladding material : ODS
Number of pins : 127

KAIST-MMR V2.0 (~2016)

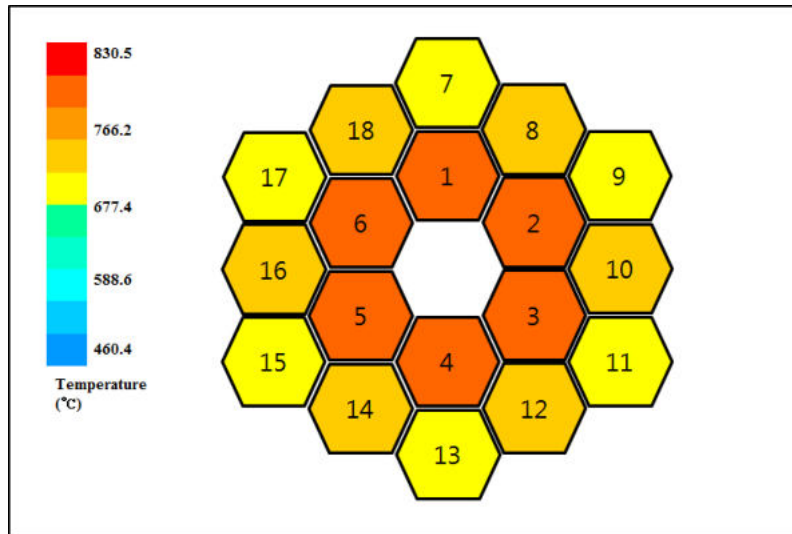
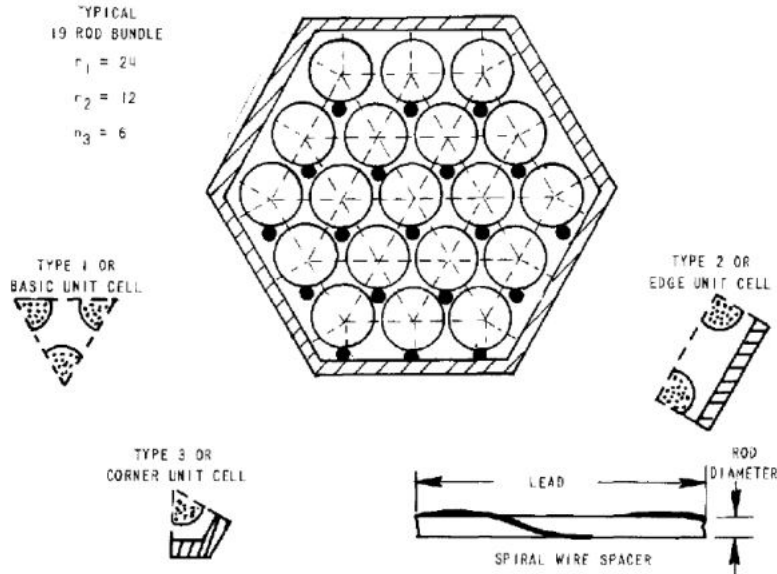

Reactor Power	36.2 MWth
Coolant Pressure	20 MPa
Coolant Inlet Temperature	382.2 °C
Coolant Outlet Temperature	550 °C
Mass flow rate	175.34 kg/sec
Fuel Rod Out Diameter	1.5 cm
Pitch/Diameter Ratio	1.13
Hydraulic Diameter	0.00612 cm
Flat to Flat Diameter	20.105 cm
Duct Thickness	0.3cm
Wire Diameter	0.195 cm
Number of Turns	47
Hottest Assembly Peaking Factor (UN)	1.139
Hottest Assembly Peaking Factor (UC)	1.177
Axial Peaking Factor	1.308

KAIST-MMR V2.0 (~2016)

❖ Passive Decay Heat Removal system (PDHR)

- PDHR is designed to passively remove decay heat after reactor scram
 - Driven power of PDHR flow rate is natural circulation from temperature difference
 - For redundancy, there are two PDHRs in MMR
 - Ultimate heat sink is air to be independent on water source

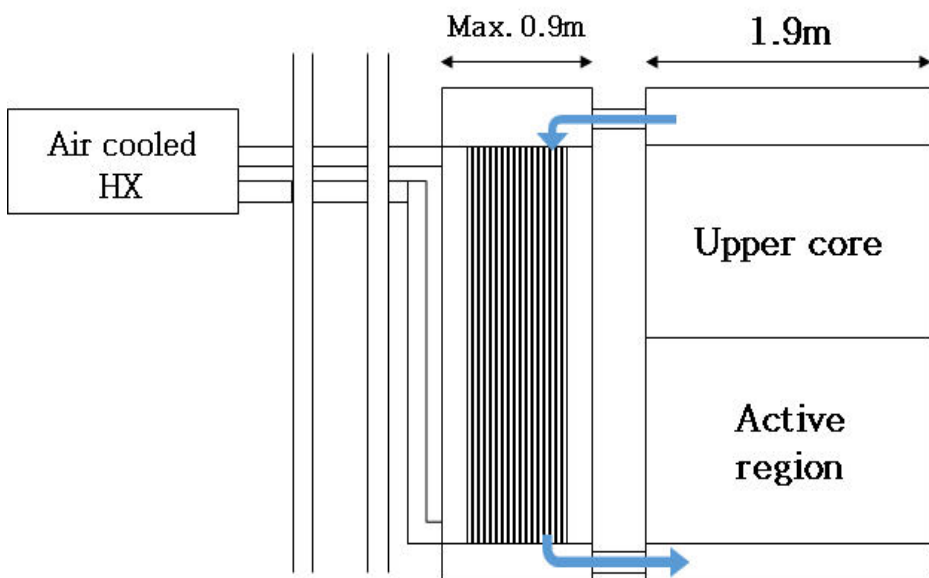

<PDHR schematic diagram>

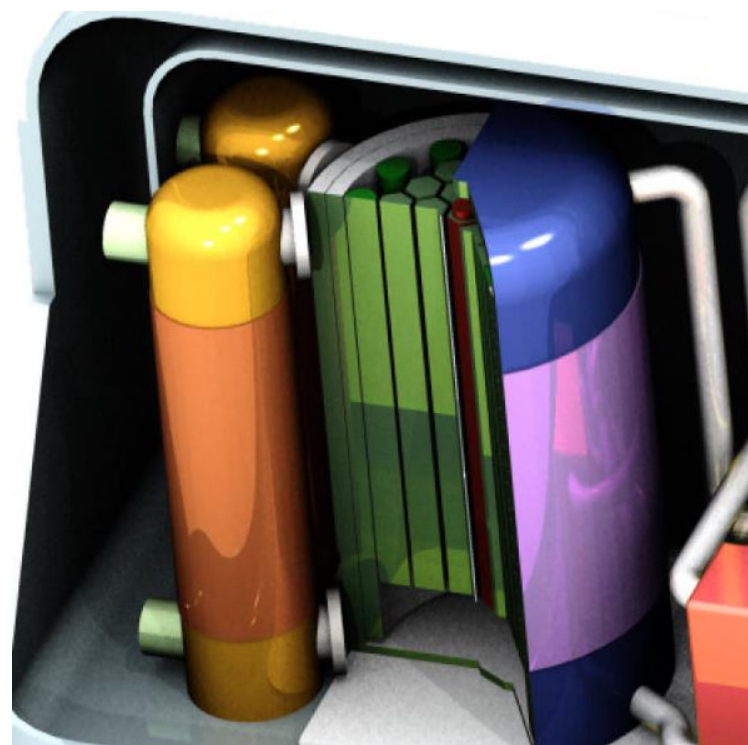

<Configuration of PDHR>

KAIST-MMR V2.0 (~2016)

❖ Double-wall containment

- To have thermal and pressure buffer in severe accident, MMR containment is adequately filled with CO₂ inventory
- Total mass is evaluated as around 150 tons and It is available to be transported.



<Ground Transportation of MMR>

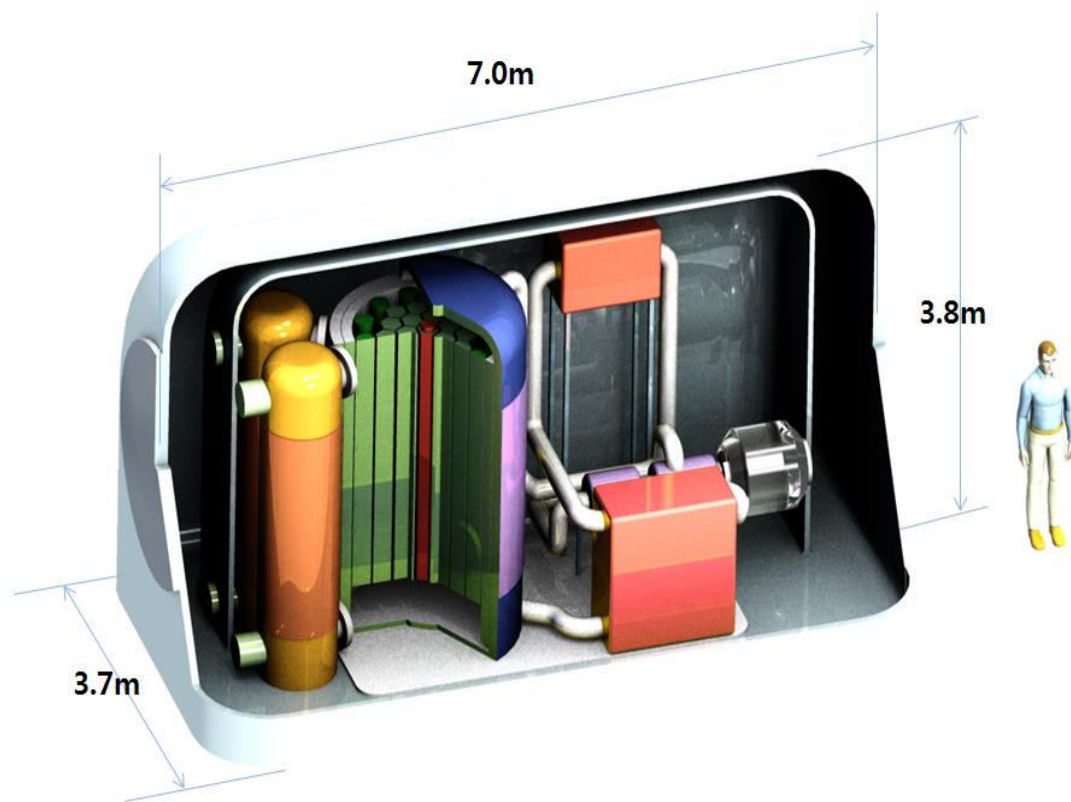

<Configuration of MMR>

KAIST-MMR V2.0 (~2016)

- Difficulties on S-CO₂ Brayton cycle component design procedure
 - Critical point
 - Temperature : 30.98°C (304.13K)
 - Pressure : 7377 kPa
 - Top requirement of S-CO₂ Brayton cycle
 - Near critical point operation is top requirement of S-CO₂ Brayton cycle for high efficiency.
 - Non-ideal behavior of S-CO₂ near the critical point
 - Due to its dramatic change of thermodynamic properties of S-CO₂, S-CO₂ compressor performance prediction is hard to have reliable results.

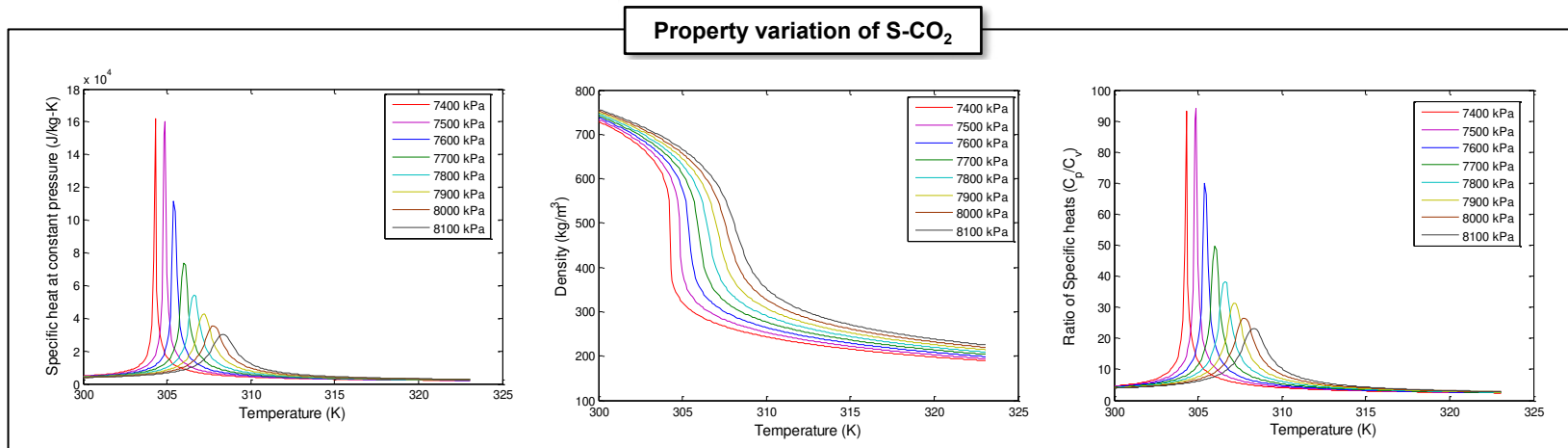
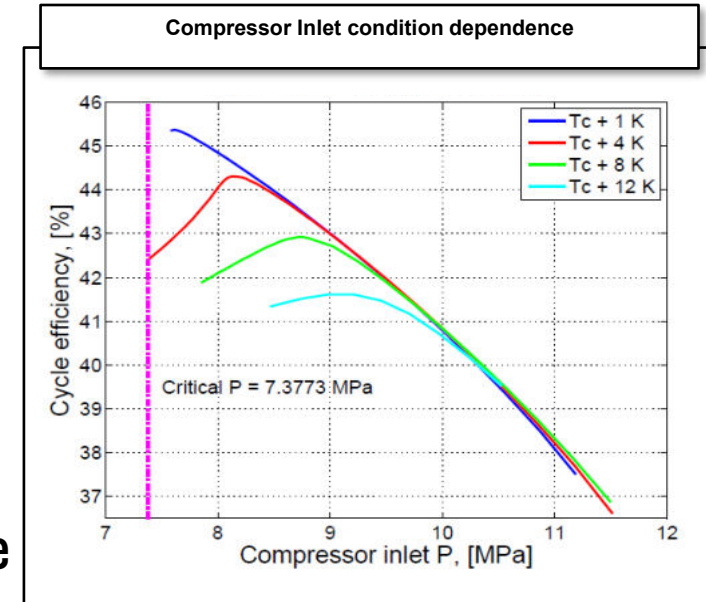

KAIST-MMR V2.0 (~2016)

Recompression S-CO₂ Brayton cycle layout

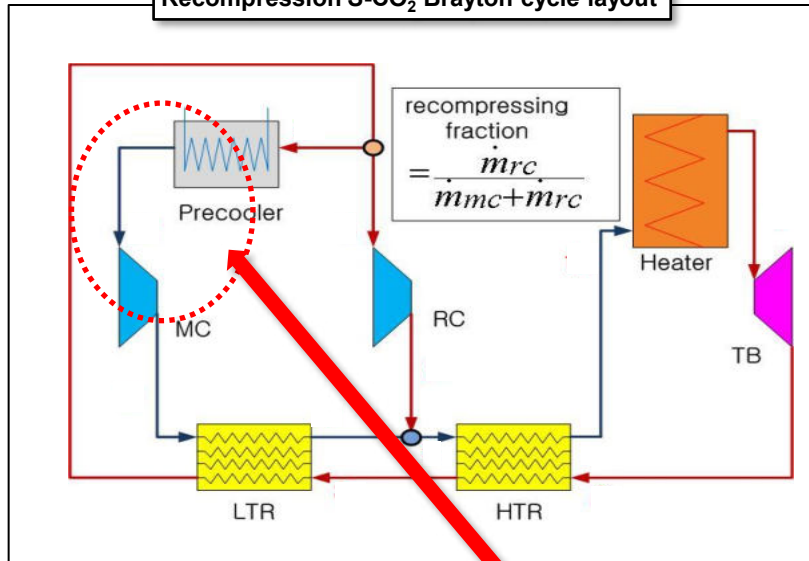

T-s diagram of recompression layout

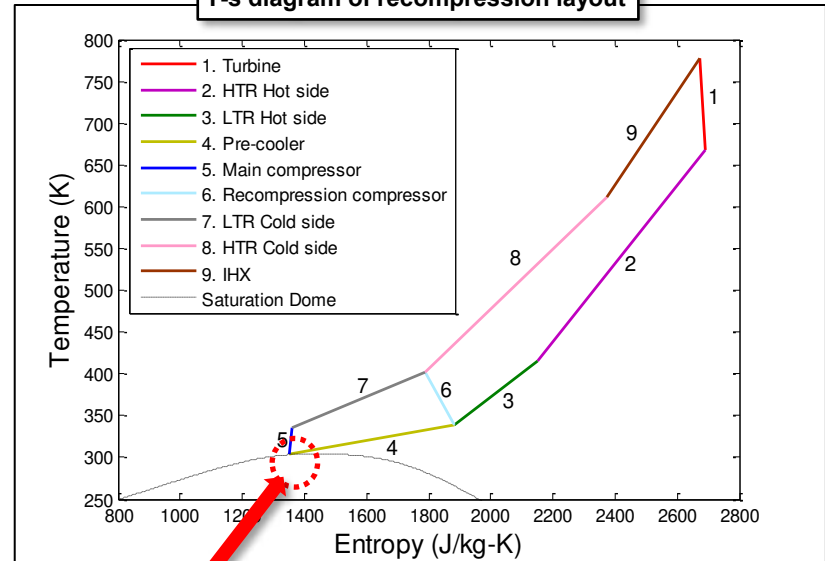

Dramatic change of thermodynamic properties near the critical point

Advanced design methodologies are required to secure reliability of Compressor and Pre-cooler designs

KAIST-MMR V2.0 (~2016)

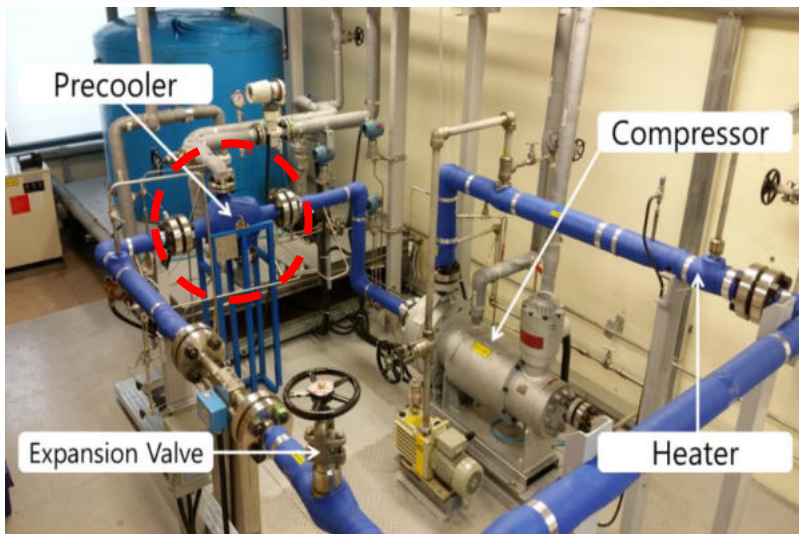
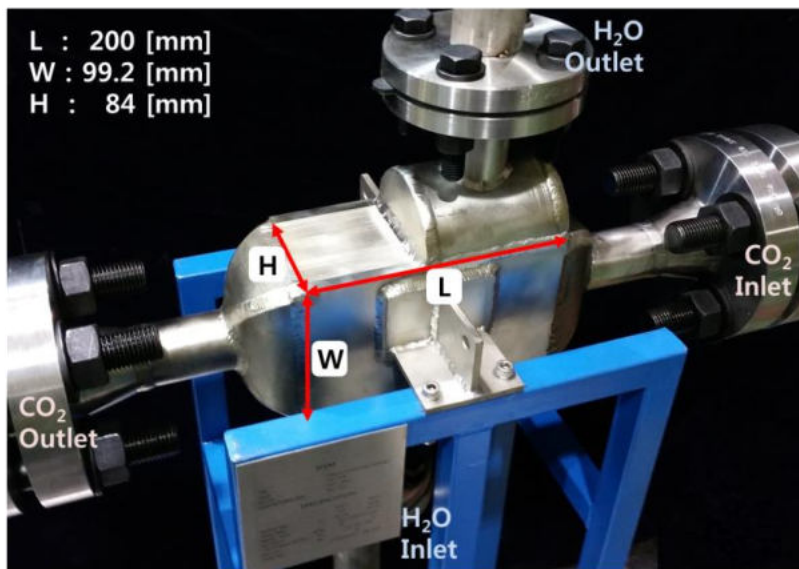

<KAIST-SCO2PE>

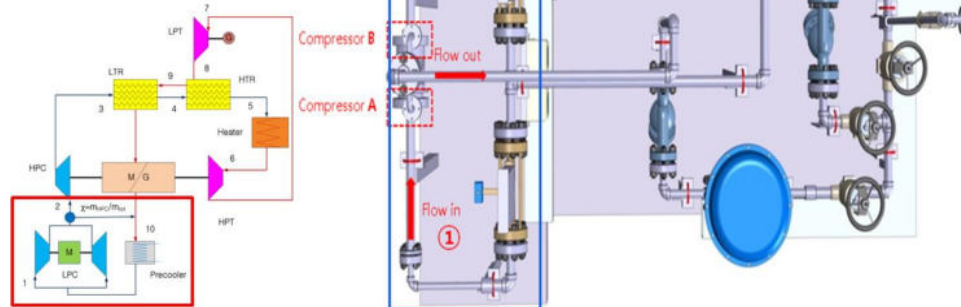

<KAERI-SCIEL>

KAIST-MMR V2.0 (~2016)

➤ Phase changing experiment

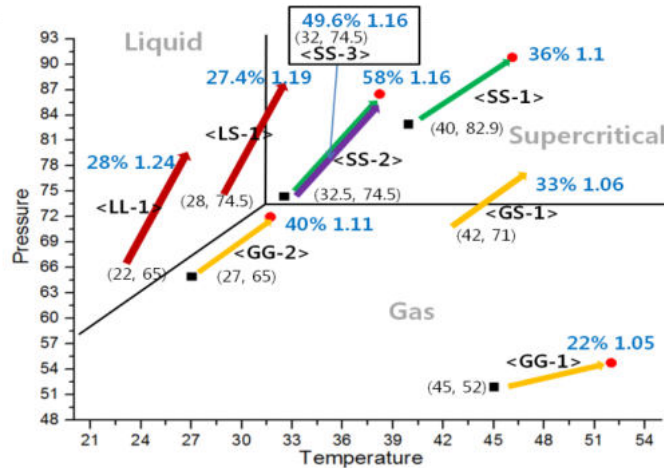

Operating results with various compressor inlet conditions.

1. Supercritical to Liquid case [Sound change]

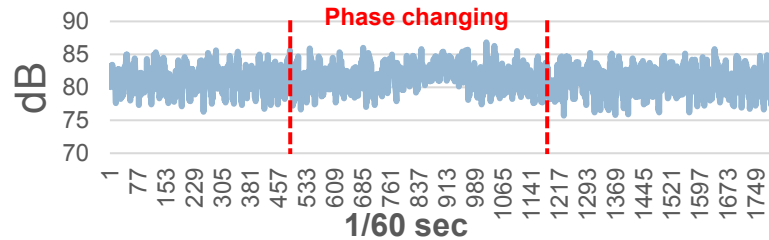

2. Liquid to 2-phase case [Sound change]

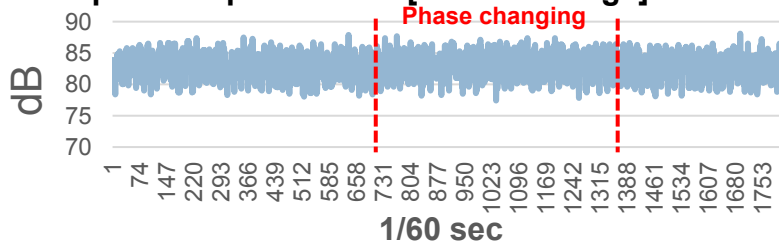

1. Supercritical to Liquid case



2. Liquid to 2-phase case

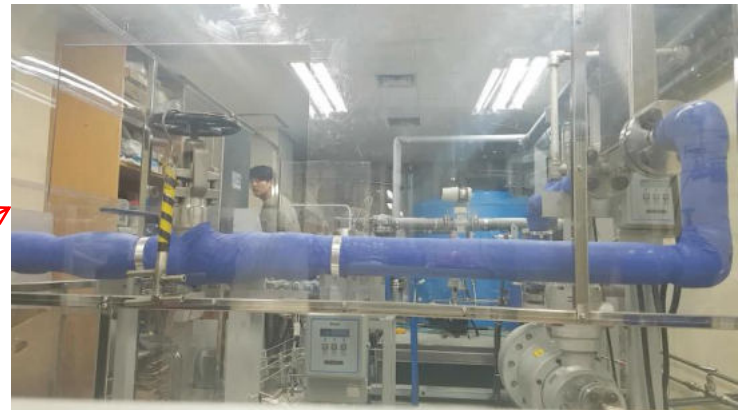

KAIST-MMR V2.0 (~2016)

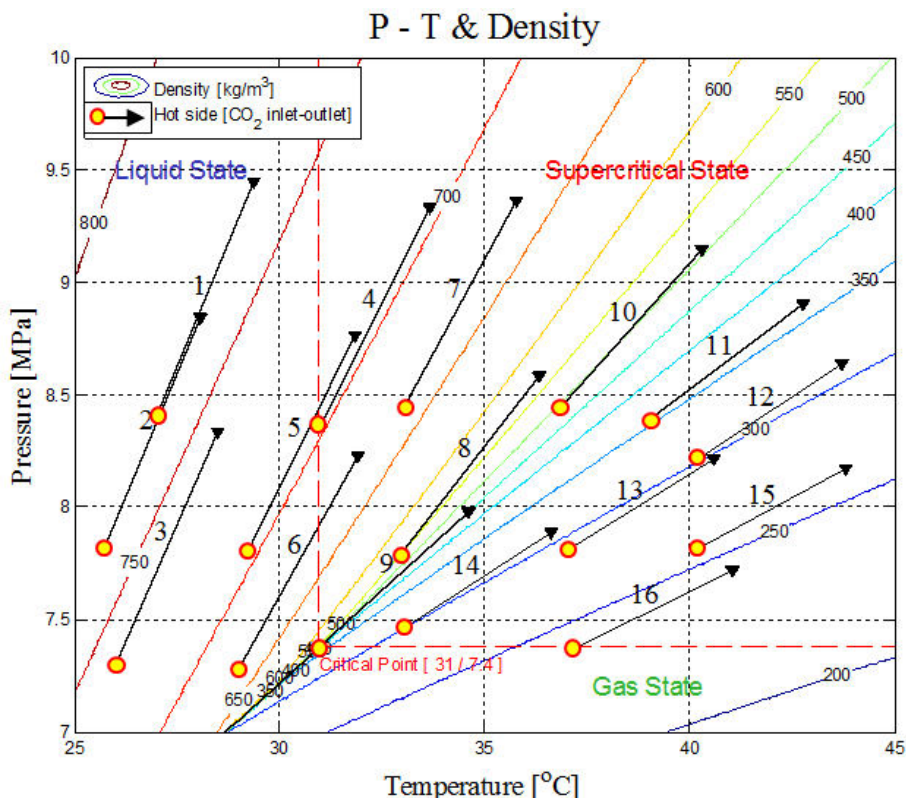

<KAIST-SCO2PE Test Cases>

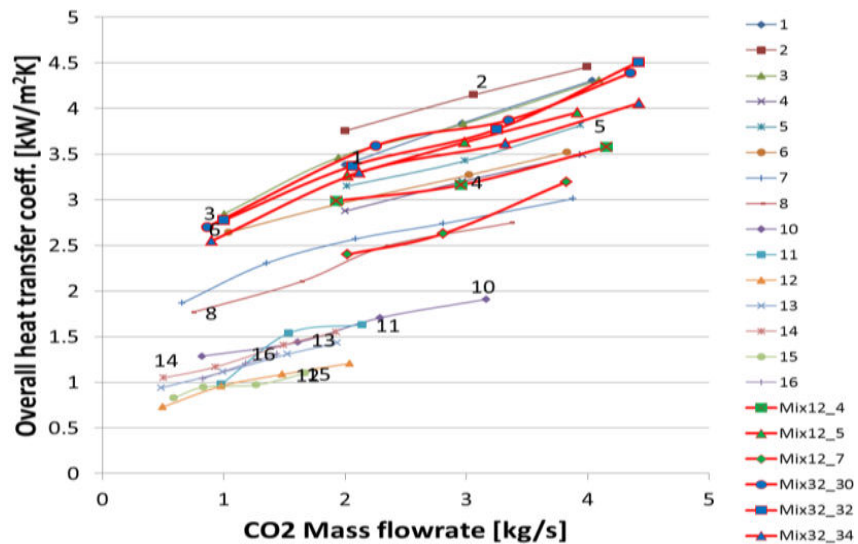
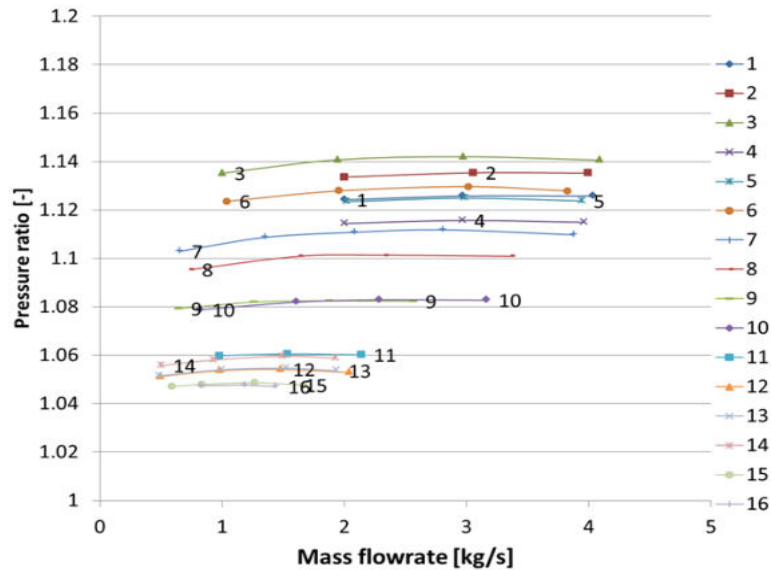

KAIST-MMR V2.0 (~2016)

Transient analysis

- Compressor performance maps support transient analysis for abnormal system operation scenarios

KAIST_TMD

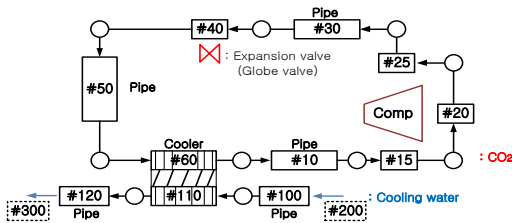
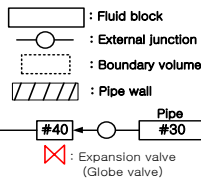
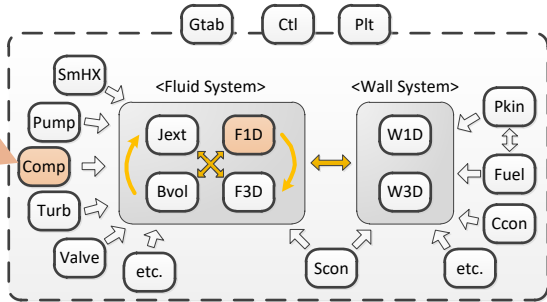

KAIST_TMD

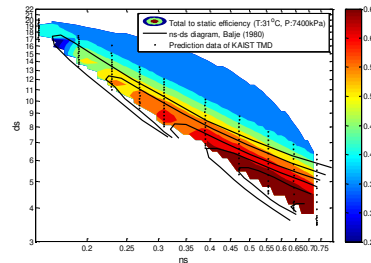
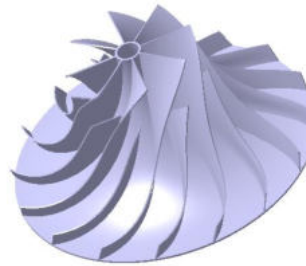
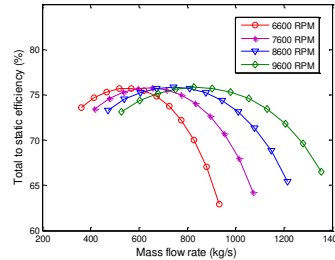

3D CFD analysis

- Internal flow analysis can be supported by 3D CFD analysis
- Complementary assistance platform can be constructed from 3D model information generation

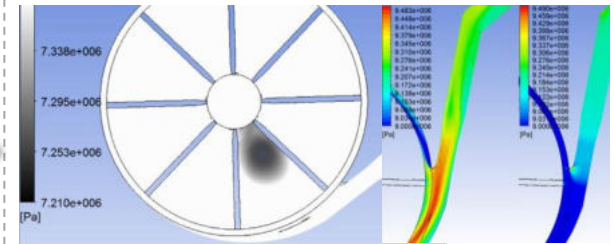

Realistic cycle design

- Enhances reliability on cycle analysis can be obtained since reliable non-dimensional design map can be supported

KAIST-MMR V2.0 (~2016)

KAIST_HXD

- Objective is to design and analyze the precooler of S-CO₂ Brayton cycle due to rapid change of properties
- Existing heat exchanger analysis methods (LMTD, ϵ -NTU) cannot be applicable
- 1D FDM PCHE analysis code for counter-current case
- Calculation process

➤ Heat transfer

$$Q = U A \Delta T = \frac{1}{R_{conv.Hot} + R_{cond} + R_{conv.Cold}} A \Delta T = \frac{1}{\frac{1}{h_{Hot}} + \frac{t}{k_{cond}} + \frac{1}{h_{Cold}}} A \Delta T$$

➤ Pressure drop

$$\Delta P = 4f \frac{l}{D} \frac{\rho V^2}{2}$$

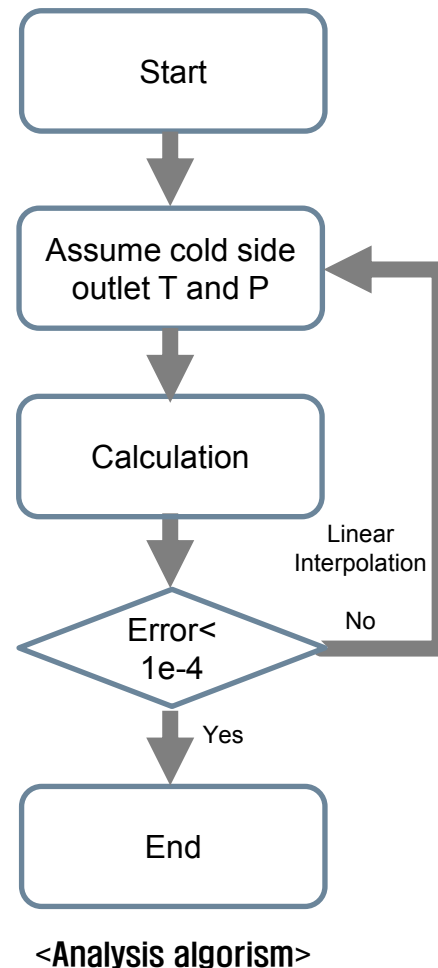
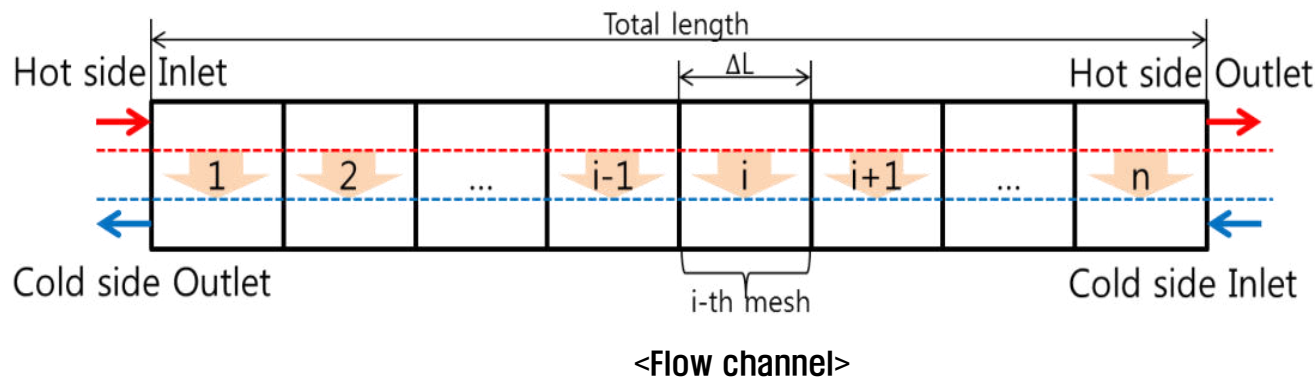

KAIST-MMR V2.0 (~2016)

- ❖ Modification of GAMMA+ code for S-CO₂ power cycle
 - GAMMA+ code is originally developed to simulate gas-cooled reactor
 - Modification of the GAMMA+ code for S-CO₂ power cycle
 - **NIST database** is adopted into GAMMA+ code to obtain exact CO₂ properties
 - Turbomachinery modeling module by **performance map** is added into GAMMA+ code
 - Modified GAMMA+ code was validated by the SCO₂PE facility

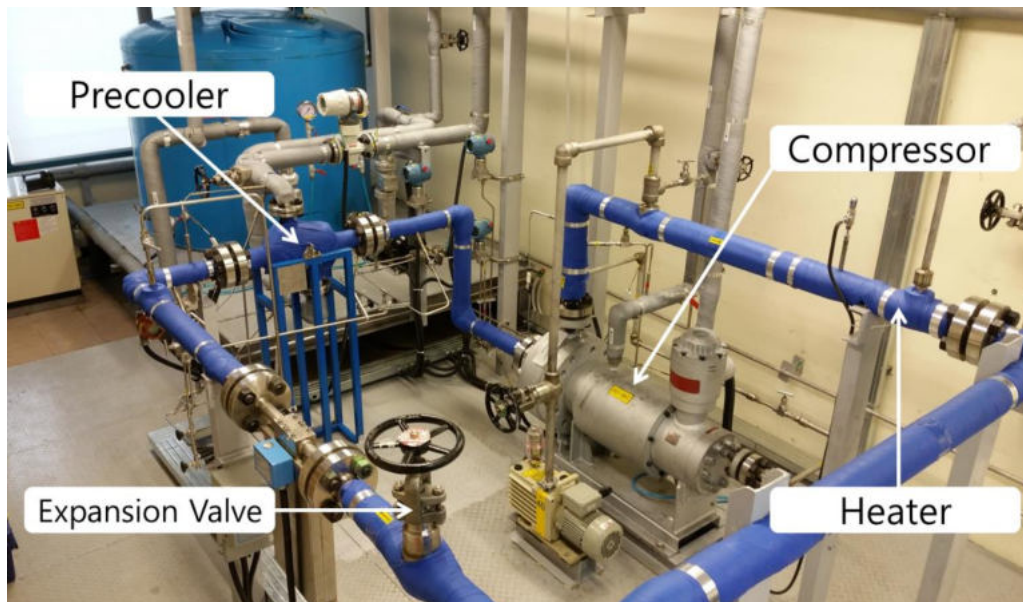

<SCO₂PE facility modeling with modified GAMMA+ code>

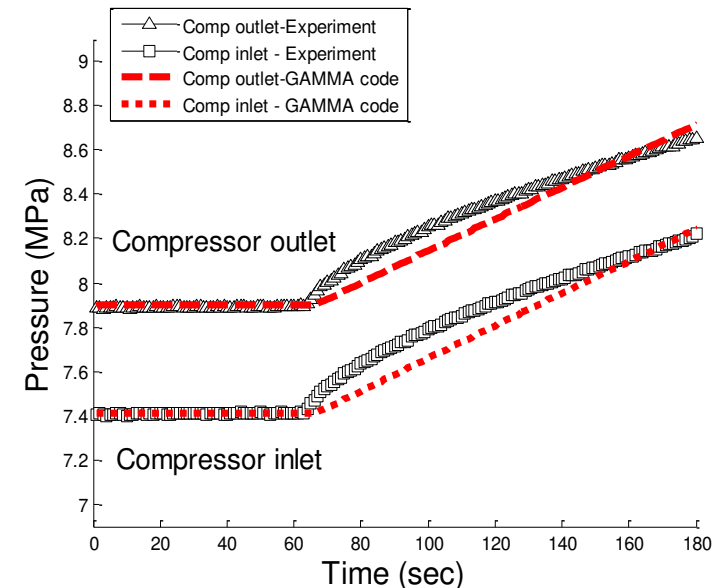

<SCO₂PE facility modeling with modified GAMMA+ code>

KAIST-MMR V2.0 (~2016)

❖ Part load operation of MMR

➤ After automatic controllers are designed, part load operation is simulated

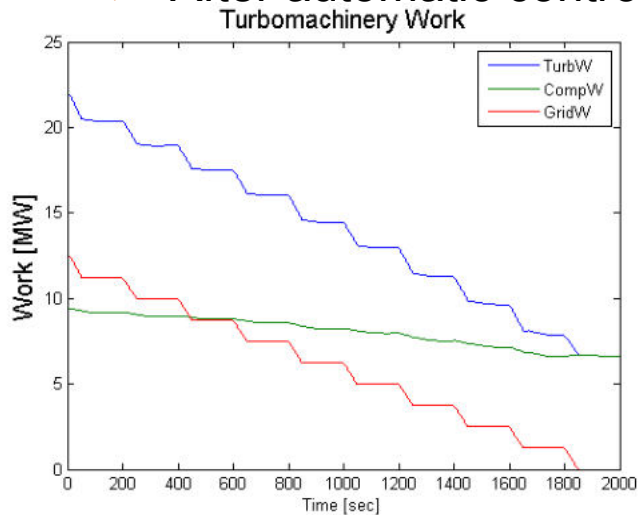

➤ Power is autonomously decreased by external load change

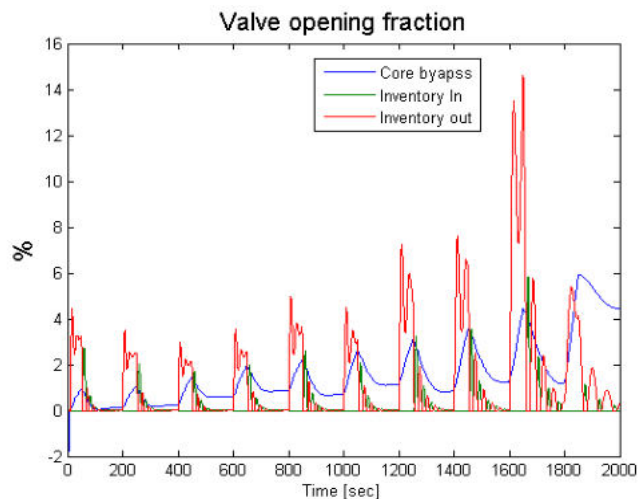

➤ Valve is automatically controlled by the controllers

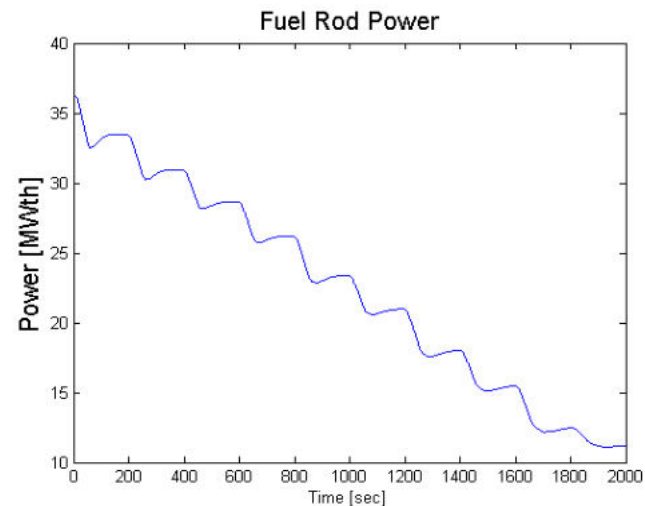
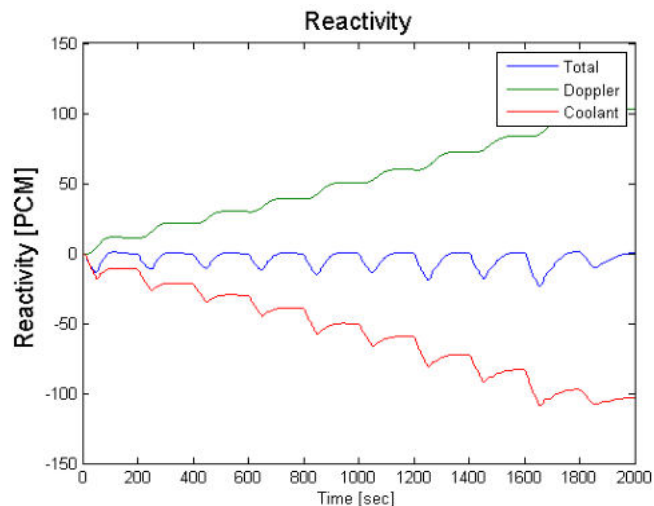

KAIST-MMR V2.0 (~2016)

❖ Design Basis Accident Simulation

- Loss of Coolant Accident (LOCA), Loss of Load (LOL), LOCA Without Scram (LOCA-WS), LOL-WS, LOCA with assuming single failure of PDHR system (LOCA-SF), LOL-SF.

❖ Beyond Design Basis Accident Simulation

- LOCA-WS-SF, LOL-WS-SF

❖ Safety features of MMR

- Turbine bypass, Venting valve, Feed valve, PDHR system

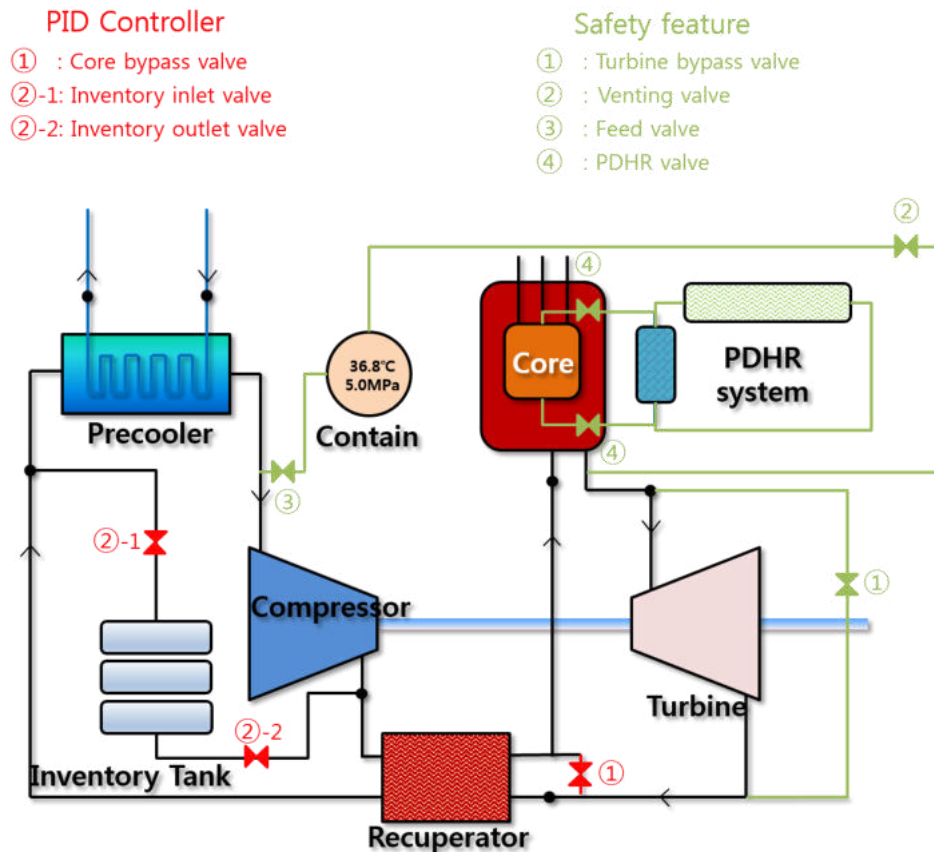

KAIST-MMR V2.0 (~2016)

❖ Simulation result of LOCA-WS-SF

➤ This accident scenarios has the most serious results

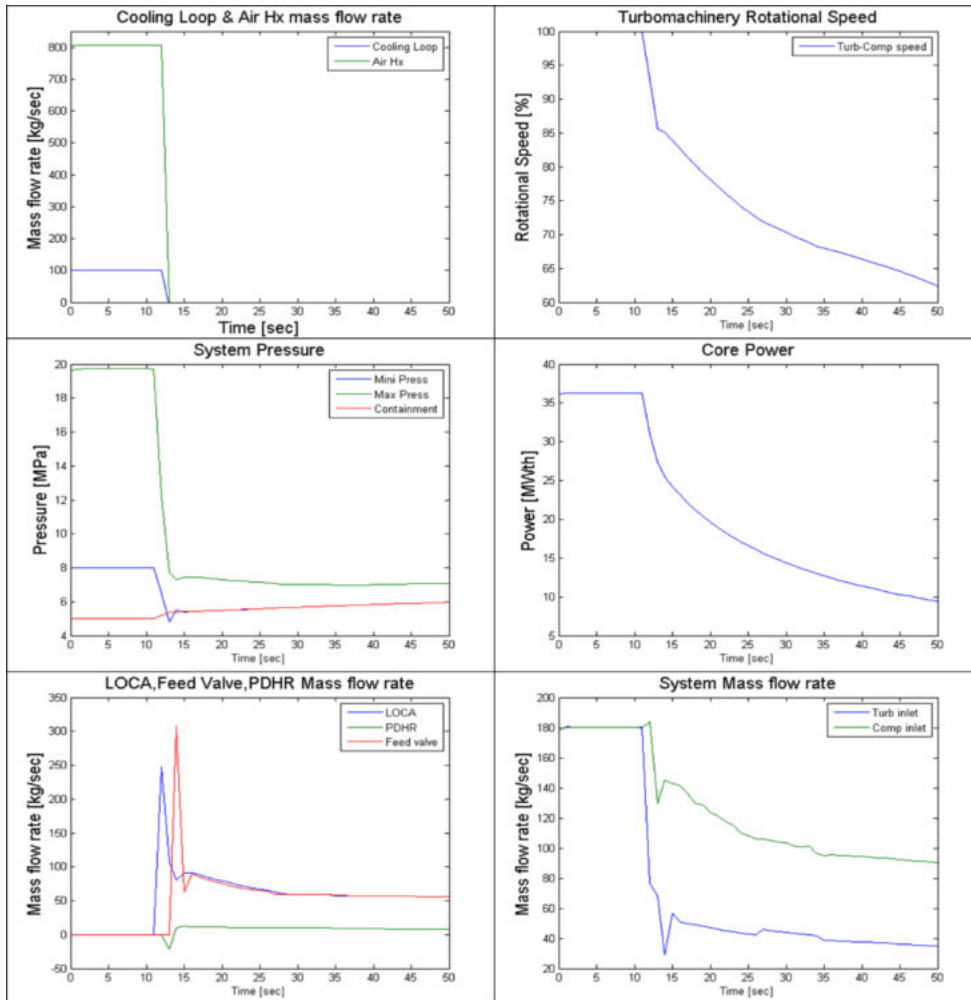

<Sequence of LOCA-WS-SF>

Time	Event	Set Point
10.0	Pipe is broken with 100in ²	-
11.61	Generation of low pressure shutdown signal	16.08 MPa
11.61	Generation of PDHR valve opening signal	16.08 MPa
12.55	Generation of feed valve opening signal	$P_{\text{containment}} > P_{\text{compressor inlet}}$

KAIST-MMR V2.0 (~2016)

❖ Simulation results of accidents

- Safety limit is mentioned from ASME code and PSAR of PWR
- LBLOCA-WS-SF has the most marginal result
- However, all of accident simulations don't be expected severe fuel damage.

<Accident results of MMR>

	$T_{\text{fuel}} (\text{°C})$	$T_{\text{clad}} (\text{°C})$	$P_{\text{max}} (\text{MPa})$	$N_{\text{turb}} (\%)$
Safety limit	2507.0	1200.0	24.0	125.0
LOL	820.0 (Nominal)	661.0 (Nominal)	21.8	114.0
SBLOCA	822.0	723.2	20.0 (Nominal)	100.0 (Nominal)
LBLOCA	820.0 (Nominal)	757.2	20.0 (Nominal)	100.0 (Nominal)
LOL-WS	828.8	766.6	21.8	114.0
SBLOCA-WS	935.5	885.9	20.0 (Nominal)	100.0 (Nominal)
LBLOCA-WS	1105.6	1082.4	20.0 (Nominal)	100.0 (Nominal)
LOL-SF	820.0 (Nominal)	661.0 (Nominal)	21.8	114.0
SBLOCA-SF	822.0	705.6	20.0 (Nominal)	100.0 (Nominal)
LBLOCA-SF	820.0 (Nominal)	750.8	20.0 (Nominal)	100.0 (Nominal)
LOL-WS-SF	824.0	768.4	21.8	114.0
SBLOCA-WS-S F	884.5	825.0	20.0 (Nominal)	100.0 (Nominal)
LBLOCA-WS-S F	1116.3	1097.4	20.0 (Nominal)	100.0 (Nominal)

KAIST-MMR V2.0 (~2016)

Location	Dimensions	Volume	Material	Density	Weight
Core ⁽¹⁾	2.8m (H) 1.5m (Dia.)	4.9m ³	UC, ODS s teel, B ₄ C, PbO	UC : 13,630kg/m ³ ODS : 7,250kg/m ³ B ₄ C : 2,520 kg/m ³ PbO : 9,530 kg/m ³	39 tons
Vessel	2.8m (H) 1.9m (dia.) 9.52cm (T)	0.657m ³	SA533B (Mo Alloy)	7,850 kg/m ³	4.0 tons
Pre-cooler	-	0.309m ³	SS316	8,000 kg/m ³	2.0 tons
Recuperator	-	0.596m ³	SS316	8,000 kg/m ³	2.7 tons
Containment material (Outside)	6.8m (L) 4.0m (Dia.) 2.1cm (T)	1.69m ³	SS310	8,000 kg/m ³	13.4 tons
Containment material (Inside)	5.5m (L) 3.2m (Dia.) 6.33cm (T)	3.49m ³	SS310	8,000 kg/m ³	27.9 tons
Coolant ⁽²⁾	Outer containment 24.4m ³ (1MPa)		CO ₂	140.2 kg/m ³	0.44 tons
	Inner containment 32.2m ³ (5MPa)		CO ₂	116.2 kg/m ³	3.75 tons
	Coolant 1.56m ³ (20MPa)		CO ₂	18.2 kg/m ³	0.42 tons
	Pipe & Component		CO ₂	56.8 kg/m ³ ~ 327.3 kg/m ³	0.21 tons
Power Conversion System	-	-	-	-	40 tons
DHR system	-	-	-	-	20 tons
Total module	-	-	-	-	155 tons

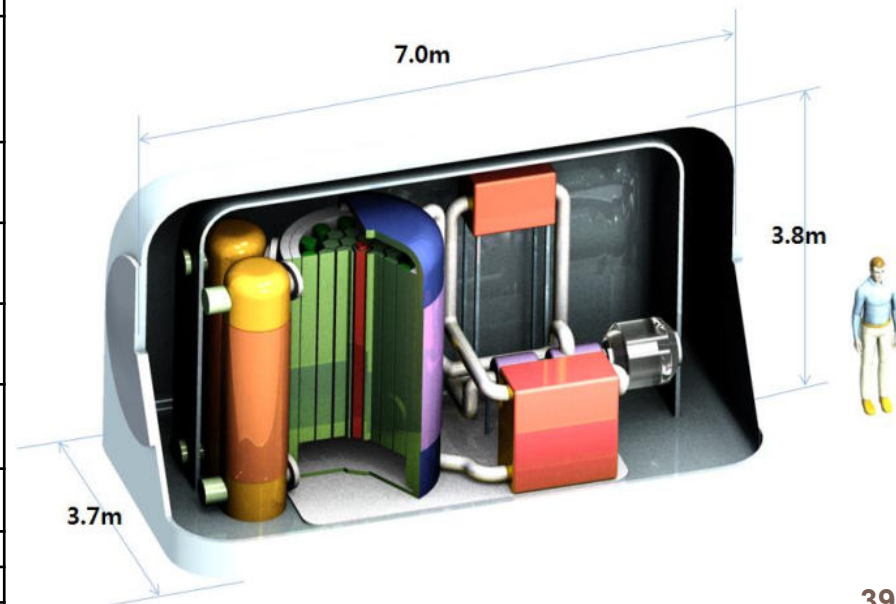
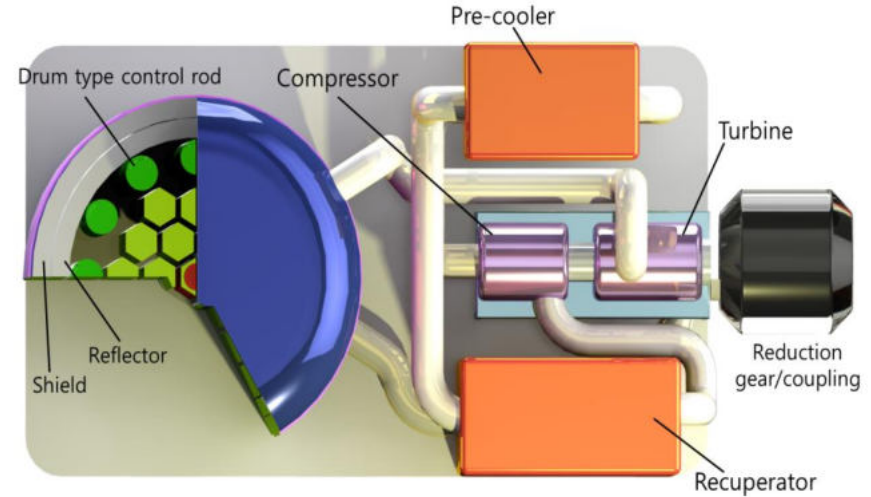

KAIST-MMR V2.0 (~2016)

KAIST-MMR: Maintenance and Operation Point of View

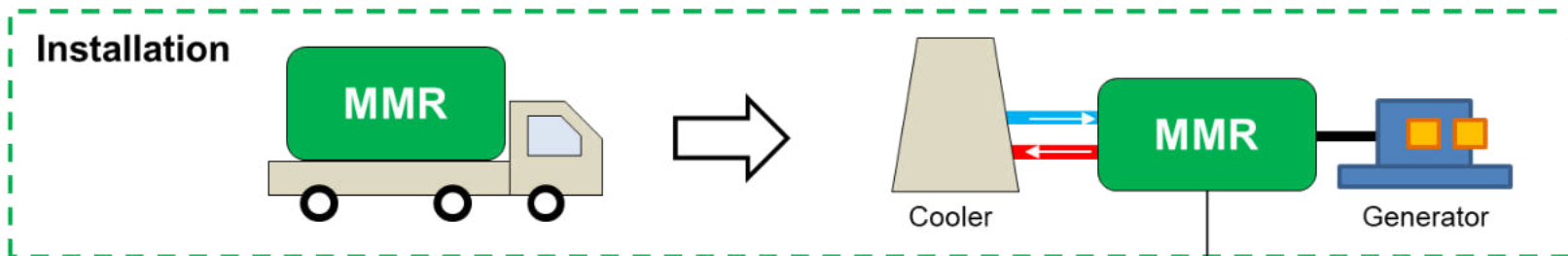

Problem 1.
What is the basis for judgment?

Failure, Trouble or Overhaul

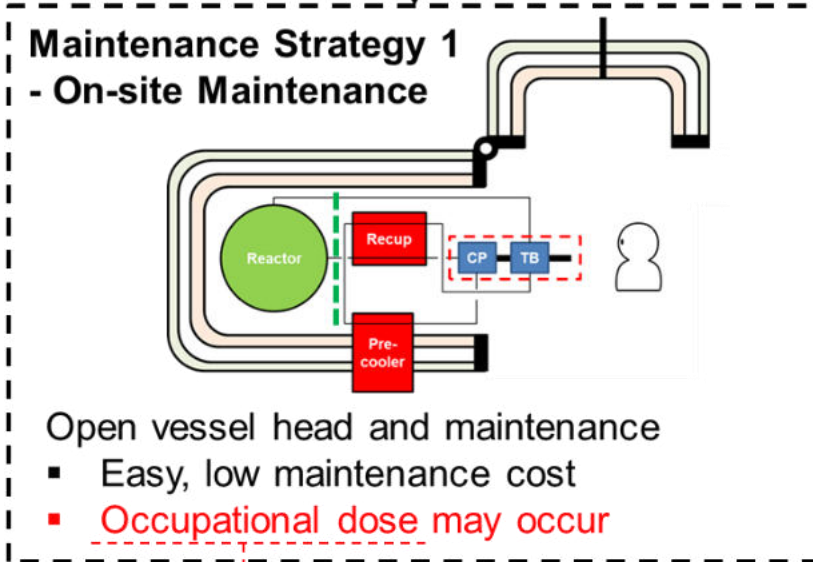

Open vessel head and maintenance

- Easy, low maintenance cost
- Occupational dose may occur

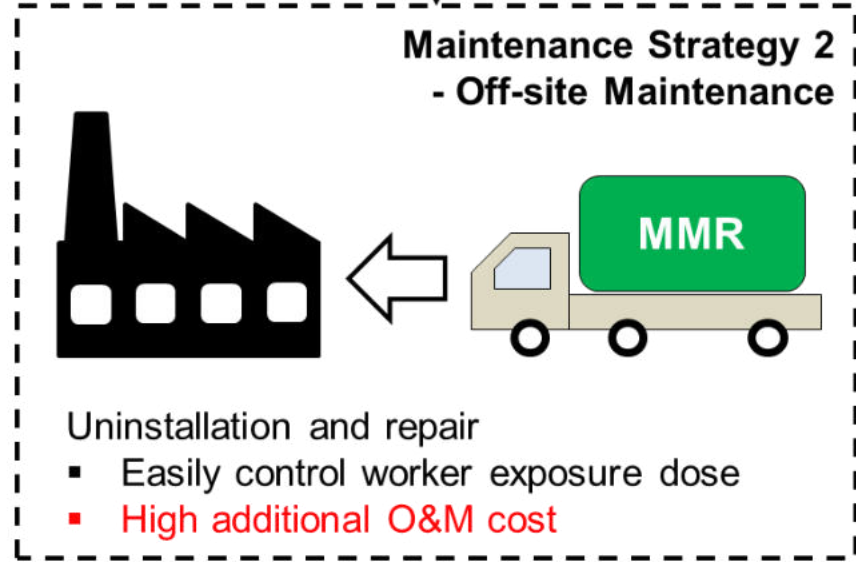

Uninstallation and repair

- Easily control worker exposure dose
- High additional O&M cost

Problem 2. How much occupational dose occurs?

KAIST-MMR V2.0 (2016)

- **Issues with KAIST-MMR V2.0**
 - ▣ **The size of 10MW generator is too big.**
 - ▣ **Reduction gear is necessary to match turbomachinery and generator RPMs.**
 - ▣ **Contactless (magnetic) torque transfer is too futuristic technology.**
 - ▣ **Transporting via ground transportation seems to be still too challenging.**
 - ▣ **Uncertainties in magnetic bearing in S-CO₂ conditions.**
 - ▣ **Turbomachinery map (scaling) is not well studied.**

KAIST-MMR V3.0 (~Ongoing)

❖ Motivation

- The newly released IMO regulation for reducing CO₂ emission forces the diesel engine on the container ship to be replaced.
 - MMR is considered as new marine propulsion system
- The genset diesel engine which has the same power with MMR (10MWe) is usually used for a small container ship with 1000 TEU (Twenty-foot Equivalent Unit, unit for describing the capacity of the 20-foot-long container) capacity.
- The diesel engine with power output of 10MW, Hyundai 20H32/40V's are 13m in length and 4.8m in height. Its weight is 153.5 tons
 - MMR power: 10MW
 - MMR scale: 7m in length, 3.8 in diameter
 - MMR weight: 154tons

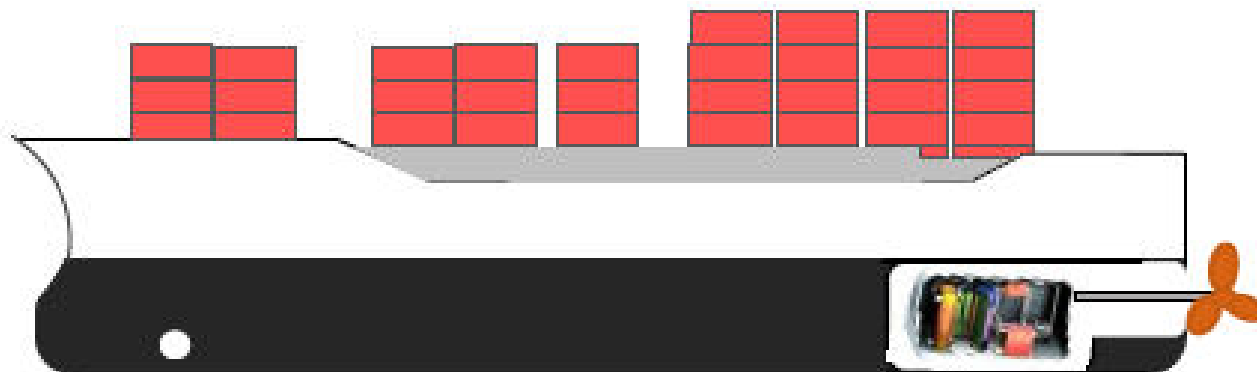

KAIST-MMR V3.0 (~Ongoing)

❖ Transient simulation of marine propulsion.

- MMR is shown that it is capable of responding torque change and engine speed from a reference marine propulsion

<On Modeling of a Ship Propulsion System for Control Purposes, Andreas Torp Karlsen, Norwegian University of Science and Technology>

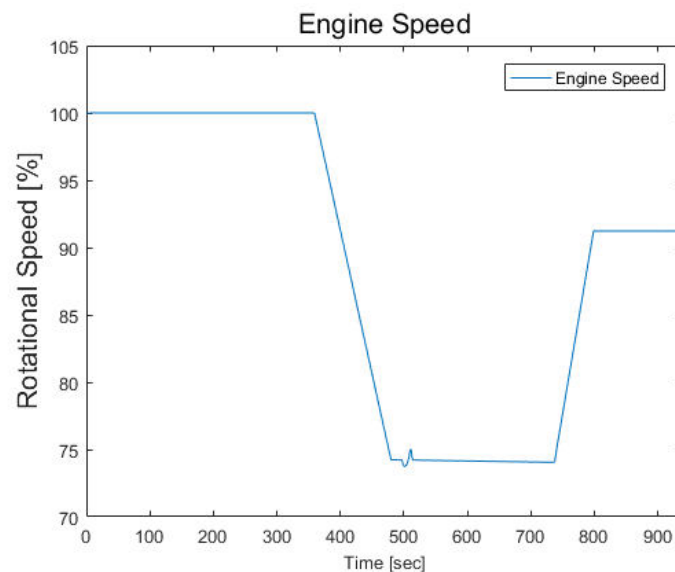
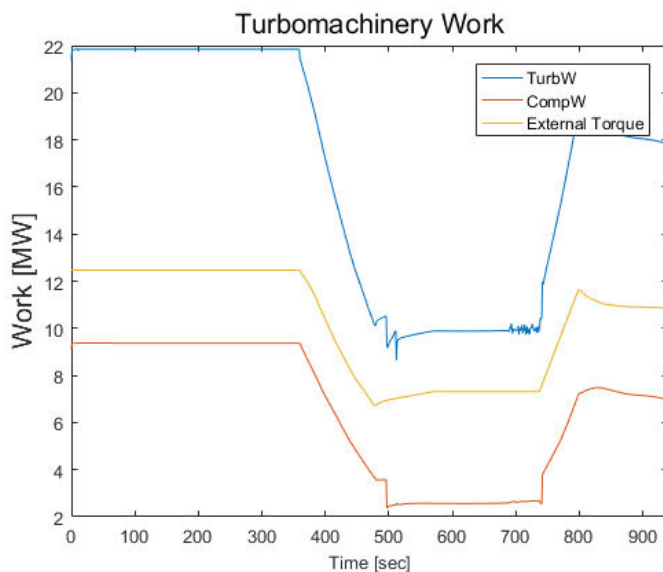

<Boundary condition of Marine propulsion: External Torque, Engine speed>

KAIST-MMR V3.0 (~Ongoing)

❖ Transient simulation results of marine propulsion.

- Even though external torque change of ship is relatively fast, MMR can respond abrupt external torque autonomously.

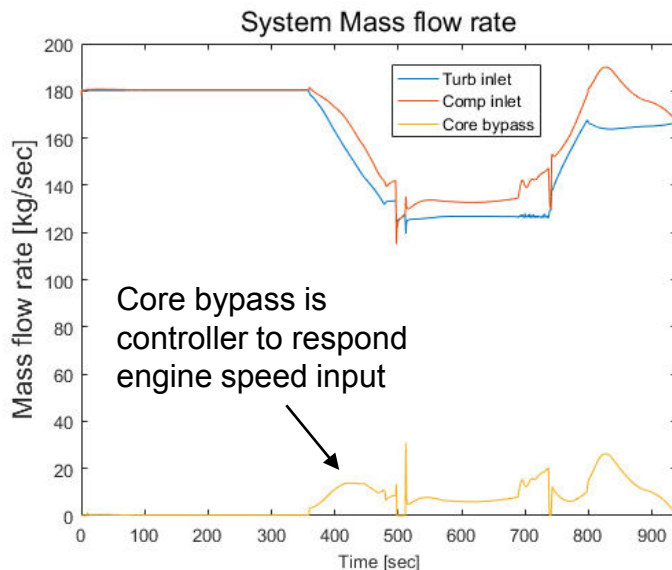

<System and bypass mass flow rate of MMR in marine propulsion>

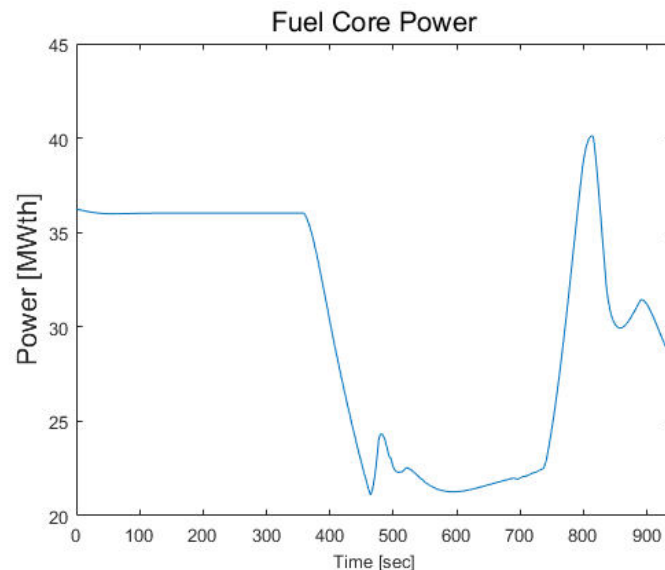

<Reactor power of MMR in marine propulsion>

- MMR shows promising results about application to marine propulsion

KAIST-MMR V3.0 (~Ongoing)

S-CO₂ test facility in KAIST

SCO₂PE facility (-2020)

(S-CO₂ Pressurization Experiment)



- No heat source
- 1 TAC
- 2 control valves
- PCHE pre-cooler
- Magnetic bearing test rig
- **Compressor test**



< AMB test rig >

ABC test loop (2021-)

(Autonomous Brayton Cycle)

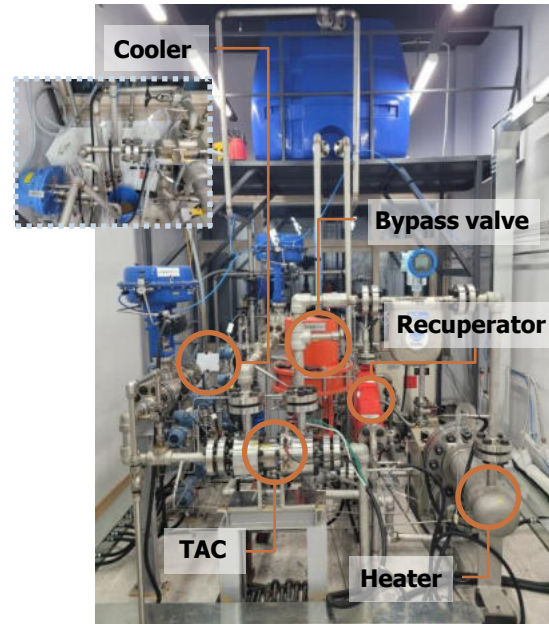

- Electric heater
- 1 TAC
- PCHE recuperator
- 2 control valves
- 1 turbine bypass valve
- 2 pre-cooler (PCHE & SNT)
- Magnetic bearing test rig
- **Autonomous control**
- **Integral test**

S-CO₂ critical flow experimental facility



- 2 tank (HP, LP)
- Heater
- Nozzle
- **Seal leakage flow**
- **Critical flow model**

KAIST-MMR V3.0 (~Ongoing)

Development of system analysis code

- Based on the nuclear system analysis code (e.g. MARS-KS and GAMMA+), system analysis code for S-CO₂ cycle is being developed.
- Properties and component models are implemented.



Code V&V with experimental results

- Verifying newly developed computational modules
- Validating the developed code with experimental results
- Modifying and updating the code to improve accuracy

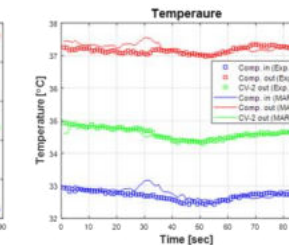
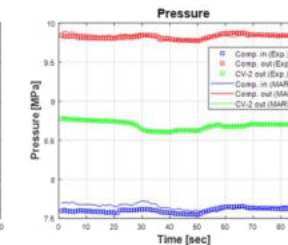
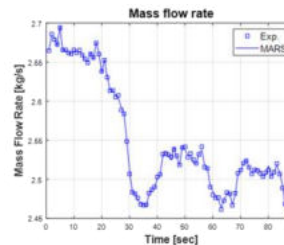
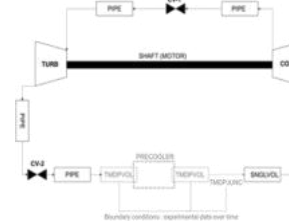
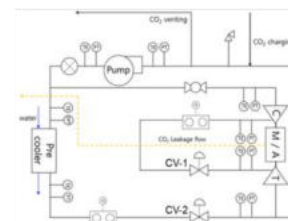

System analysis for S-CO₂ power conversion system

- Optimizing control logic of S-CO₂ power system
- Steady and transient simulation (load variation and accident)

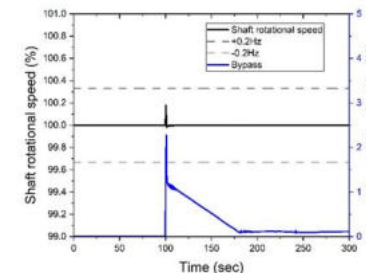
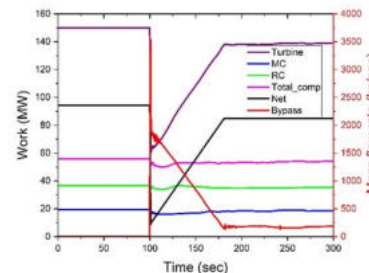
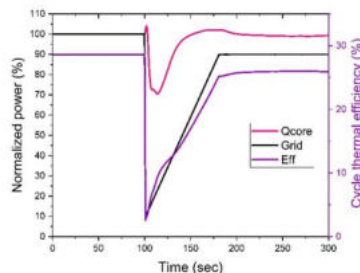
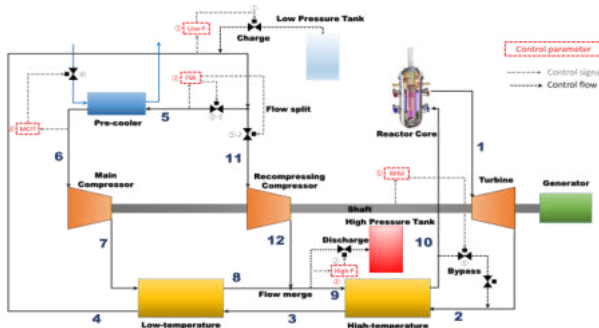

KAIST-MMR V3.0 (~Ongoing)

➤ Compressor Performance Test to Validate High Backsweep Angle Effect

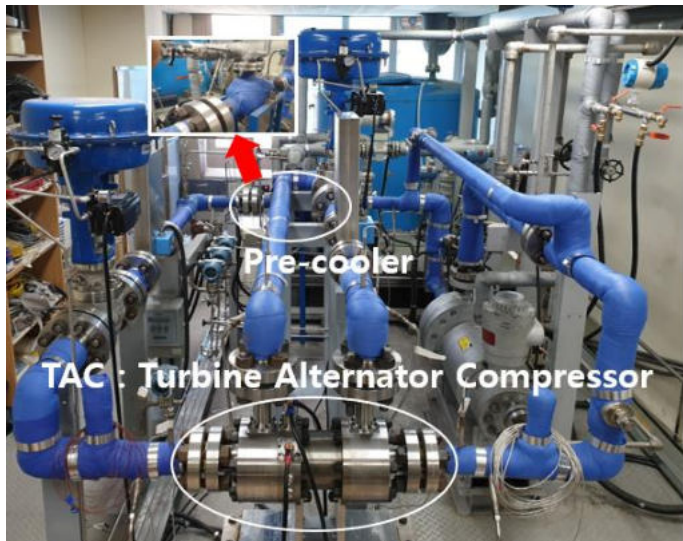

- Unlike the previous compressors such as adopted gas foil bearing or magnetic bearing, the TAC with ball bearings, which the DN is about one million, was adopted for the operability.
- Two types impellers (-50° / -70°) will be tested to confirm its performances.
- Since the S-CO₂ is an excellent solvent, the bypass was added for shaft cooling. It prevents CO₂ purity and contamination on test facility from the dissolved grease into S-CO₂.

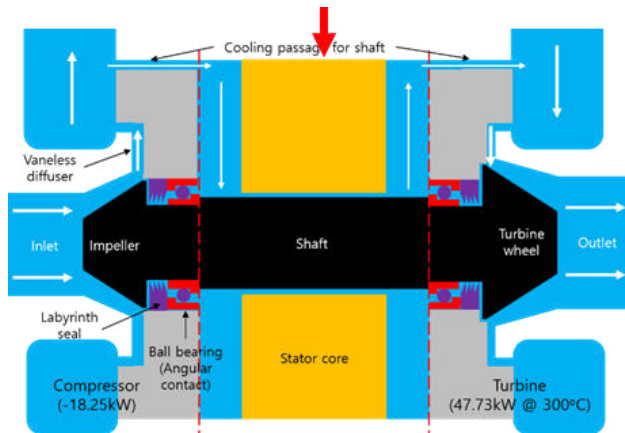
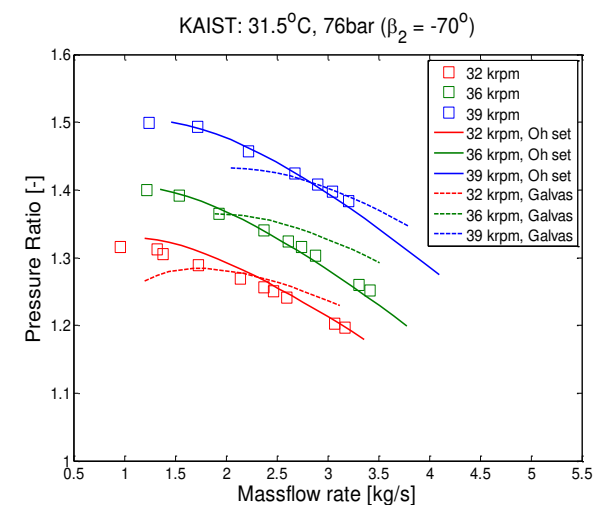
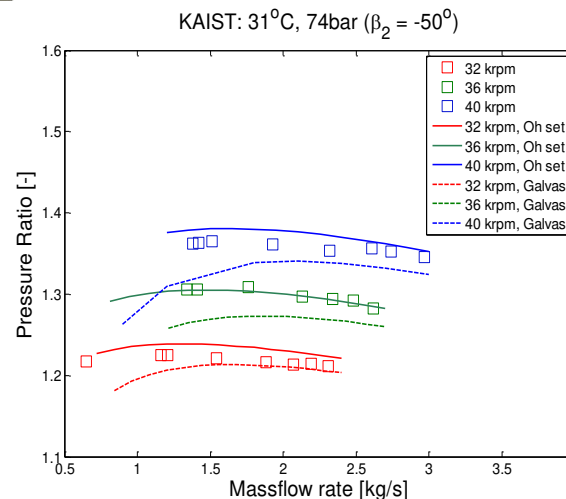
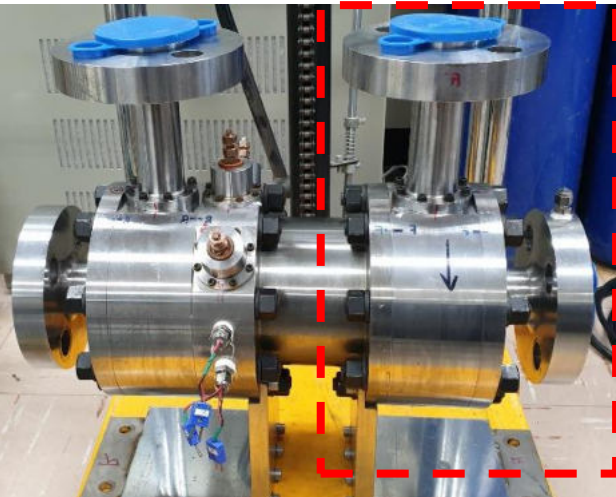

Fig. Schematic diagram of S-CO₂ TAC
(40000 RPM, PR=1.29, \dot{m} =3 kg/s @ Design point)



KAIST-MMR V3.0 (~Ongoing)



Turbo-Alternator-compressor (TAC)



Compressor impeller with different backswep angle (50°, 70°)

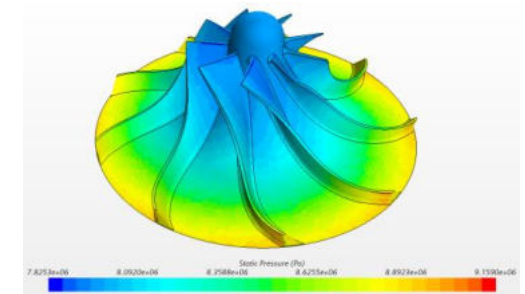
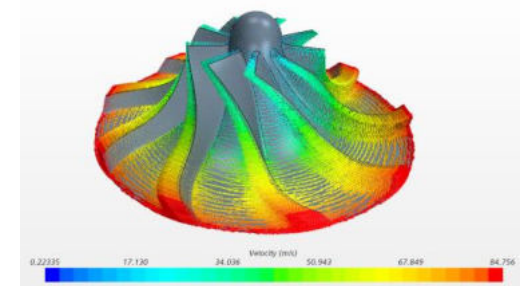

RANS simulation results (STAR-CCM+)

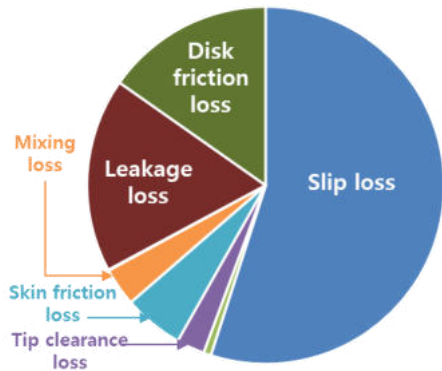

Efficiency reduction factor analysis

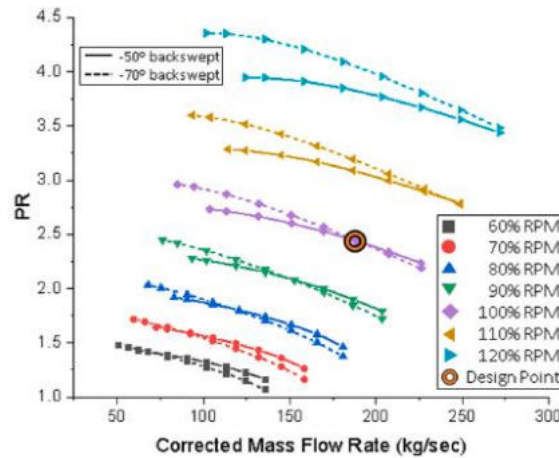

Compressor Map

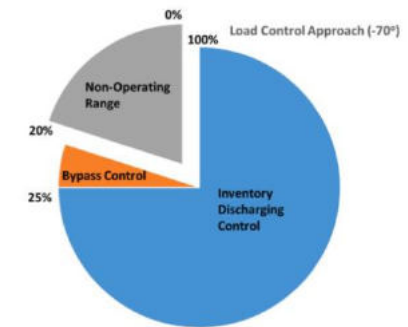
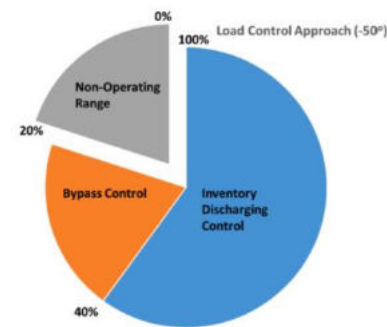

Best Control Scheme Change for Different Compressor Designs

KAIST-MMR V3.0 (~Ongoing)

Magnetic bearing lubrication analysis

- ABC loop - magnetic bearing test



Fig. Autonomous Brayton Cycle (ABC) loop & TAC with magnetic bearing

- Controlled CO₂ are injected into the AMB test system
- AMB test results : shaft trajectory data from AMB feedback sensor

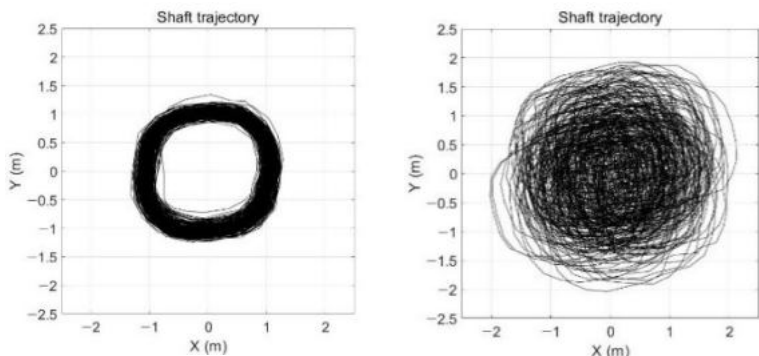

Fig. Shaft trajectory data, vacuum(left), S-CO₂(right)

Test results analysis

- Reynolds' eqn is used as governing eqn
- Lubrication analysis with random position

$$\frac{\partial}{\partial X} \left(\frac{\rho h^3}{k_x \mu} \frac{\partial p}{\partial X} \right) = \frac{\partial(\rho h)}{\partial t} + \frac{1}{2} \frac{\partial(\rho h u)}{\partial X}$$

< Reynolds' equation >

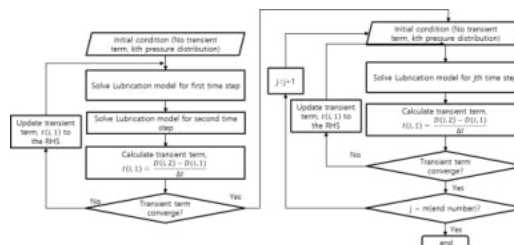

Fig. Lubrication analysis flow chart

- Lubrication analysis with trajectory data

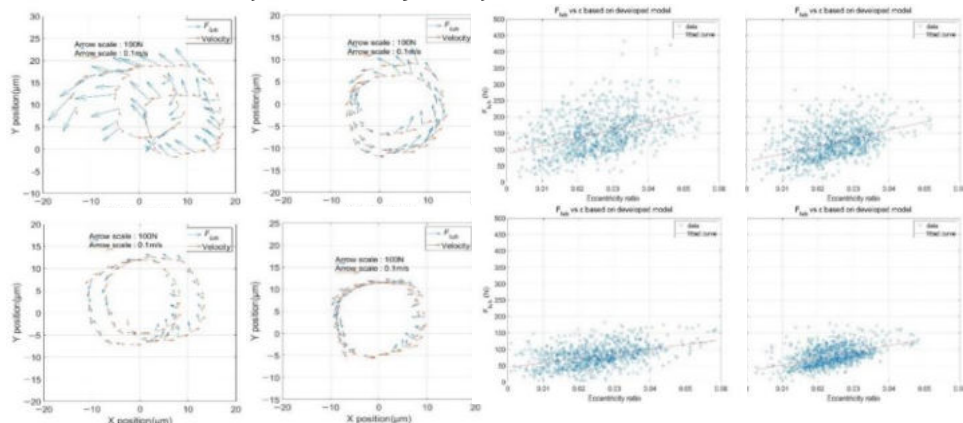

Fig. Lubrication analysis for each test

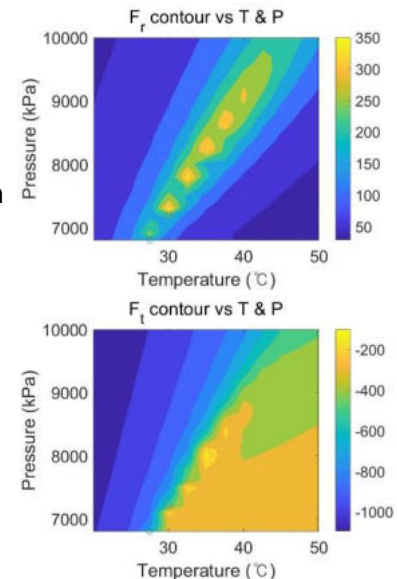

Fig. Lubrication force vs. CO₂ condition

KAIST-MMR V3.0 (~Ongoing)

- The model that could predict a loss of the fluid is needed because the leakage determines the inventory of the system, and the integrity of system eventually depends on the inventory.
- When the pressure boundary fails in a high-pressure system (S-CO₂ system), if the back pressure is lower than the critical pressure, the flow rate becomes choked.
- Choked flow models are being validated using the experimental facility for S-CO₂ application.

Region 1 : Single phase

Region 2 and 3 : Appearance of the second phase

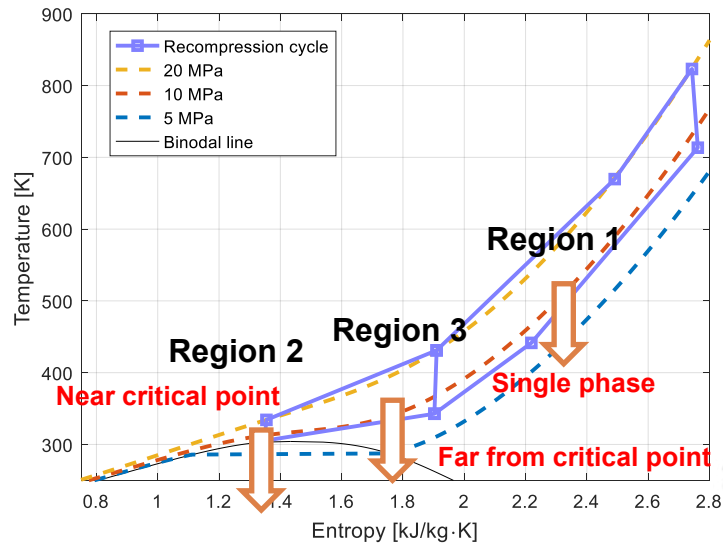

Fig. T-S diagram for CO₂ with depressurization

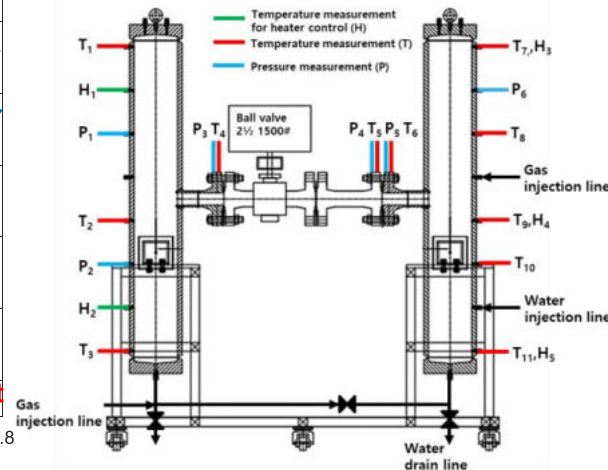

Fig. Schematic(Left) and photograph(Right) of facility

KAIST-MMR V3.0 (~Ongoing)

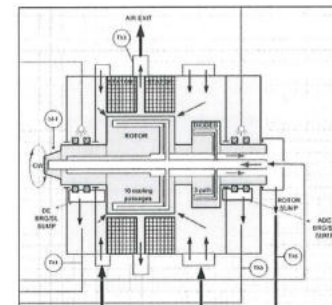
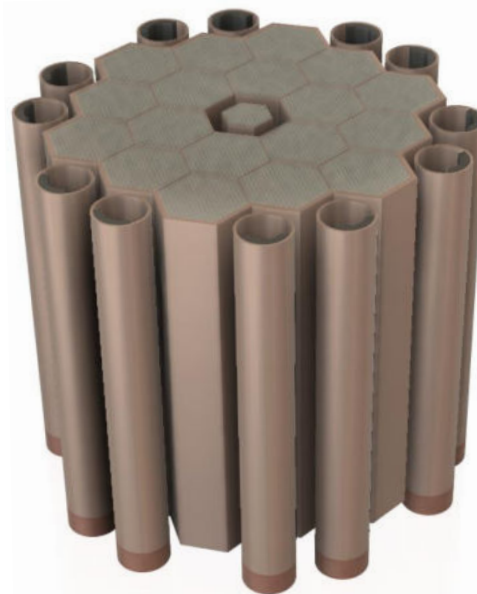
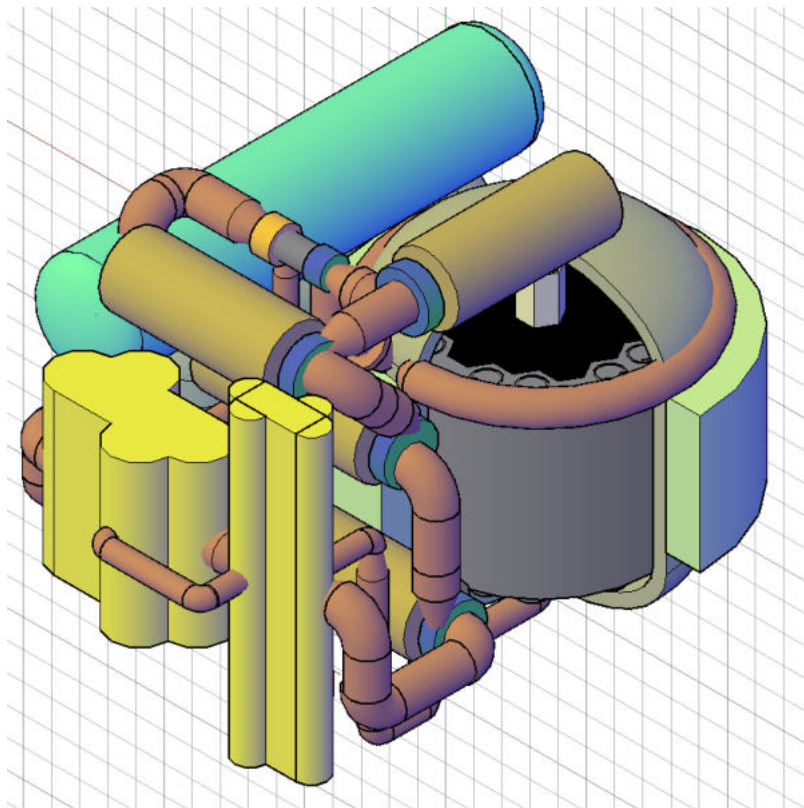

Figure 1: ALPS HS-Generator lubrication and cooling schematic.

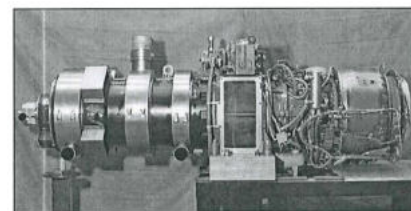
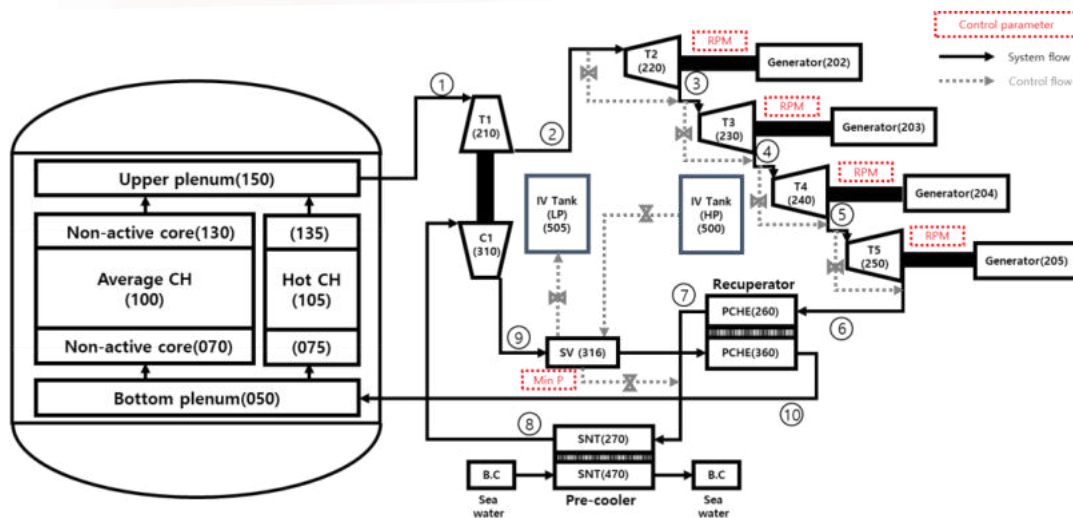

Figure 2: ALPS HS-Generator mounted with a Navy TF40b engine.



THANK YOU

ALLEGRO core design optimization

Petra Pónya, Centre for Energy Research (EK)

ponya.petra@ek-cer.hu

SafeG GFR Summer School
30.08.2022.



This project has received funding from the Euratom H2020 programme
NFRP-2019-2020-06 under grant agreement No 945041.

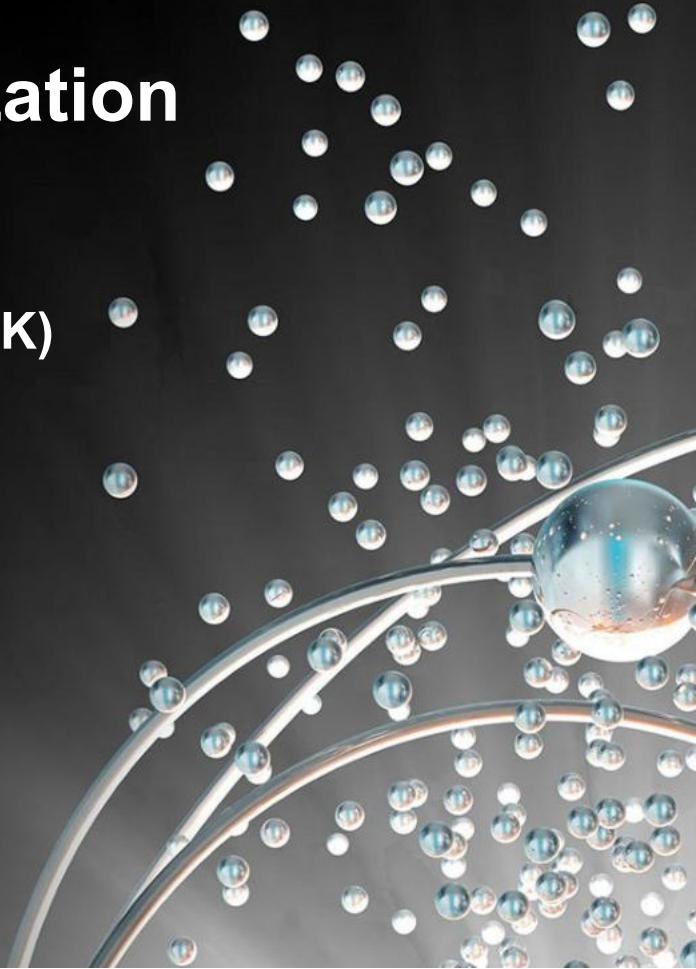

- 1. Introduction of ALLEGRO reactor**
- 2. Core design methodology overview**
- 3. Examined parameters**
- 4. Design optimization methods**
- 5. Challenges of GFR core design**

GenIV demonstrator reactor – Gas Cooled Fast Reactor concept:

- To demonstrate viability of GFR type reactors
- To test operational behavior of a new type ceramic fuel
- 75 MW thermal power
- Helium coolant: 7 MPa pressure, $T_{in}=300^{\circ}\text{C}$, $T_{out}=600^{\circ}\text{C}$

Core configurations:

- Starting core configuration: oxide fuel (MOX or UO_2)
- Ceramic fuel in some assembly positions + oxide fuel
- Final core configuration: ceramic fuel (refractory core)

„CEA-2009” design:

- 75 MW_{th} total power
- 81 MOX fuel assemblies
- 6 CSDs
- 4 DSDs
- 6 steel diluent assemblies
- 120° rotational symmetry
- 25.5_{vol}% Pu content in MOX
- B₄C absorber rods with 30% enriched ¹⁰B isotope

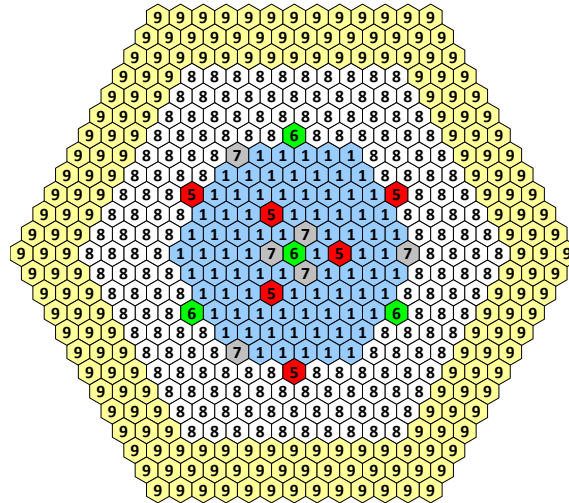

- | | |
|---|----------------------------|
| 1 | Original MOX fuel assembly |
| 5 | CSD assembly |
| 6 | DSD assembly |
| 7 | Steel diluent assembly |
| 8 | Radial reflector |
| 9 | Radial shielding |

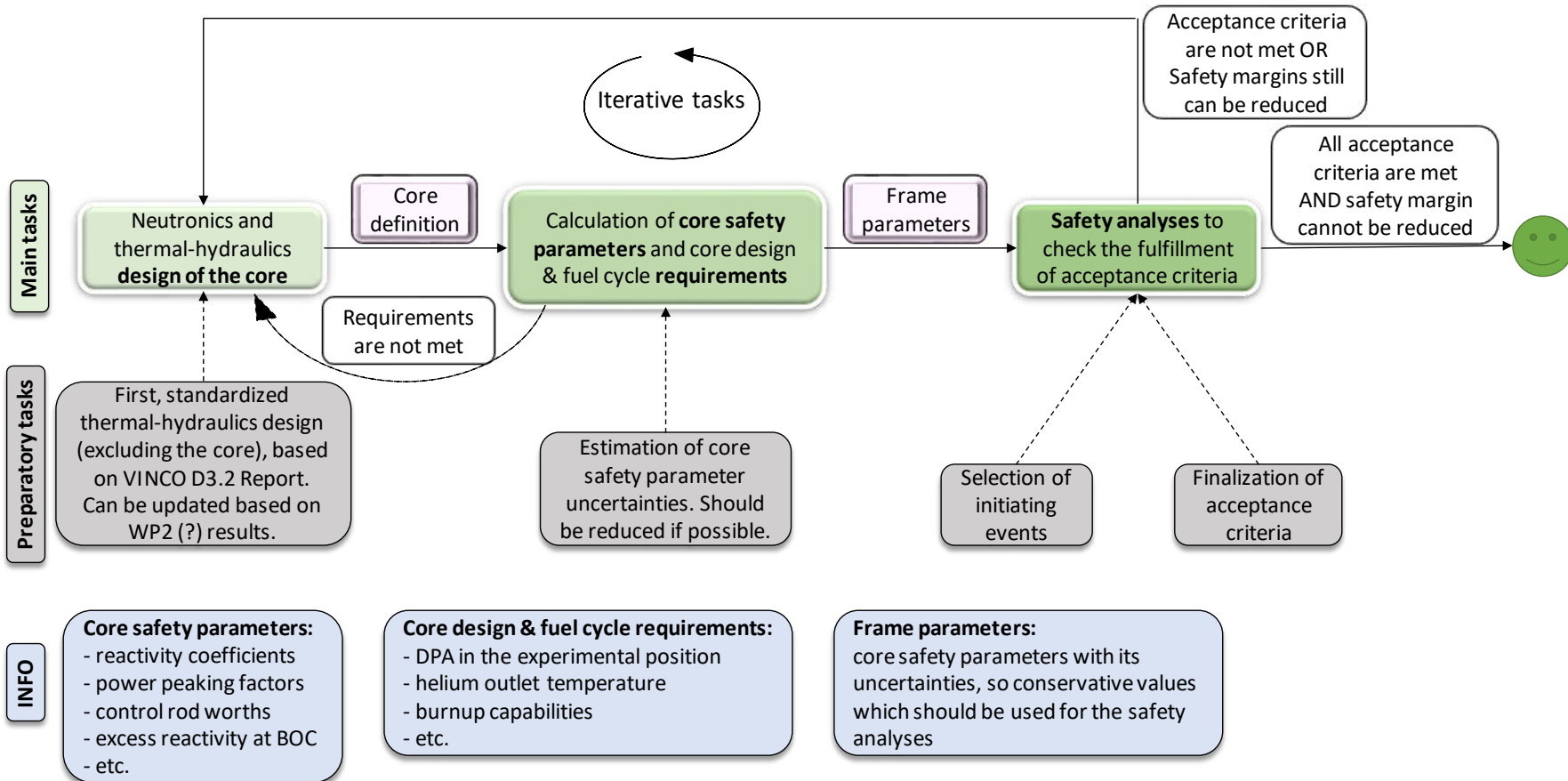

1. Core safety parameters:

- Excess reactivity at BOC
- Control rod worth
- Effective delayed neutron fraction
- Reactivity coefficients (Doppler, Doppler+fuel expansion, Void, etc.)
- Power distribution
- Power peaking factors

2. Core design requirements

- SiC dpa
- Fuel burnup

- k_{eff} – **effective multiplication factor**: the change in the fission neutron population from one neutron generation to the subsequent generation
- **Reactivity**: deviation of k_{eff} from one, indicates the state of a reactor in terms of criticality

$$\rho = \frac{k_{\text{eff}} - 1}{k_{\text{eff}}}$$

- **Excess reactivity**: the reactivity of reactor with all the absorber devices fully withdrawn from the core
- Excess reactivity at BOC shall be investigated for each core design:
 - It has to be high enough to being able to operate the reactor for the whole burn-up cycle → burn-up claculation
 - It has to be low enough to being able to shut down the reactor by the control and shutdown devices → control rod worth calculation

Control rod worth is the change in reactivity that caused by control rod motion

- Control rods must be able to safely shut down the reactor assuming all control rods are fully inserted except for the one with the highest integral reactivity worth, which is assumed to be fully withdrawn
- Integral rod worth must be limited because of inadvertent control rod withdrawal transients

Inserted control and shutdown devices	MOX (CEA-2009)		UOX	
	[\$]	[pcm]	[\$]	[pcm]
Central DSD assembly	8.07	2849	2.94	2196
1 Central CSD assembly	2.58	911	1.70	1270
1 Outer DSD assembly	0.46	162	0.56	418
1 Outer CSD assembly	0.46	162	0.35	261

Dollar: a unit of reactivity, 1 \$ - threshold of prompt criticality

$$\rho[\text{dollars}] = \frac{\rho}{\beta_{eff}}$$

$$\beta_{eff,MOX} \approx 0.0035 \text{ (350 pcm)}$$

$$\beta_{eff,UOX} \approx 0.0070 \text{ (700 pcm)}$$

Reactivity coefficients give the change in the reactivity per unit change of a given parameter:

$$\alpha = d\rho/dT$$

For inherent safety total temperature reactivity coefficient must be negative for all operational conditions

- Doppler coefficient
- Doppler+fuel expansion coefficient
- Void (coolant density) coefficient
- Cladding thermal expansion coefficient
- Diagrid thermal expansion coefficient
- Assembly wrapper expansion coefficient
- Etc.

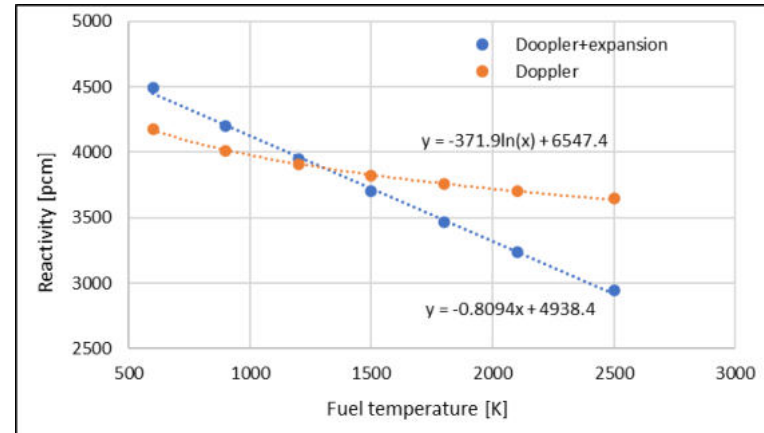

k_{eff} changes as a function of fuel temperature (Doppler) and fuel temperature plus fuel expansion (Doppler + fuel expansion)

- Radial peaking factor (radial power distribution): assembly-wise, pin-wise

$$k_{q,max} = \frac{P_{FA,max}}{P_{FA}} [-]$$

- Axial peaking factor (axial power distribution)

$$k_{Z,max} = \frac{P_{node,max}}{P_{FA,node}} [-]$$

- Maximum linear heat rate: heat generation rate per unit length of fuel rod,
 q_L [W/cm]
- Maximum assembly power [W]
- Maximum pin power [W]

Radial relative assembly power distribution (Kq) calculated by KIKO3DMG

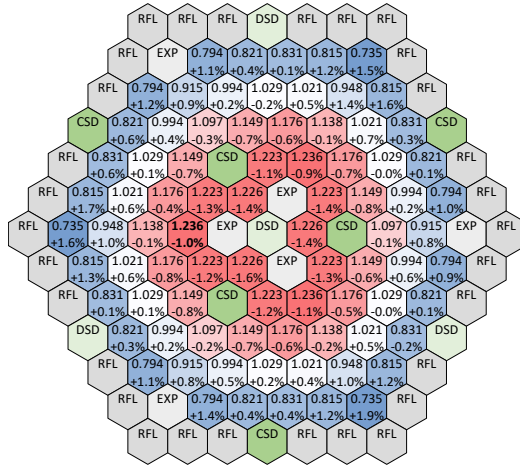

BOC

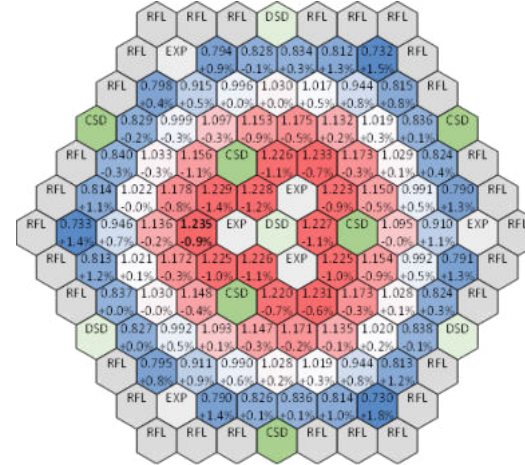

EOC (500 EFPD)

Particularly important in **transient situations**: it affects heat removal in the core → higher values lead to higher fuel cladding temperatures in transient situations.

dpa – displacement per atom:

- the number of times that an atom is displaced for a given fluence
- the measure for the amount of radiation damage in structural materials induced by neutron irradiation

SiC dpa was calculated at central height (averaged at the middle 20 cm of cladding) of one of the central experimental positions.

	dpa/EFPY	Fuel volume [m ³]
MOX	16.00	0.325
BME UOX	9.62	0.670

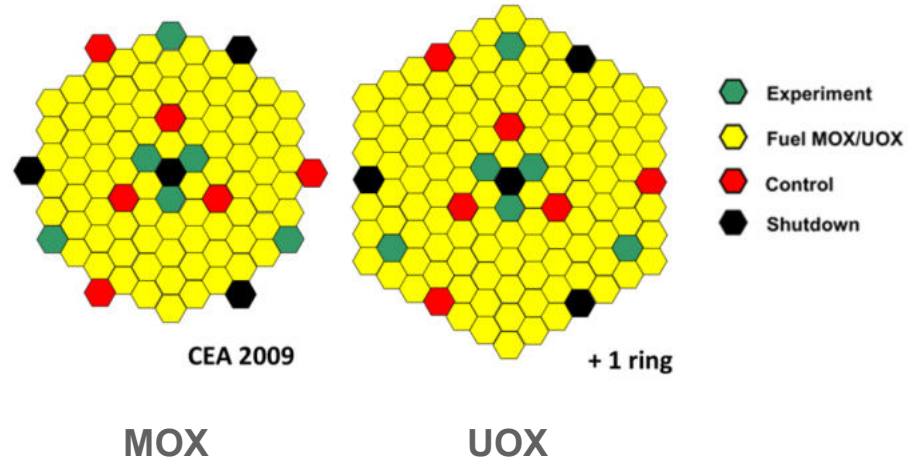

Limiting parameters → *Maximum fuel burnup*
→ *Length of the fuel cycle*

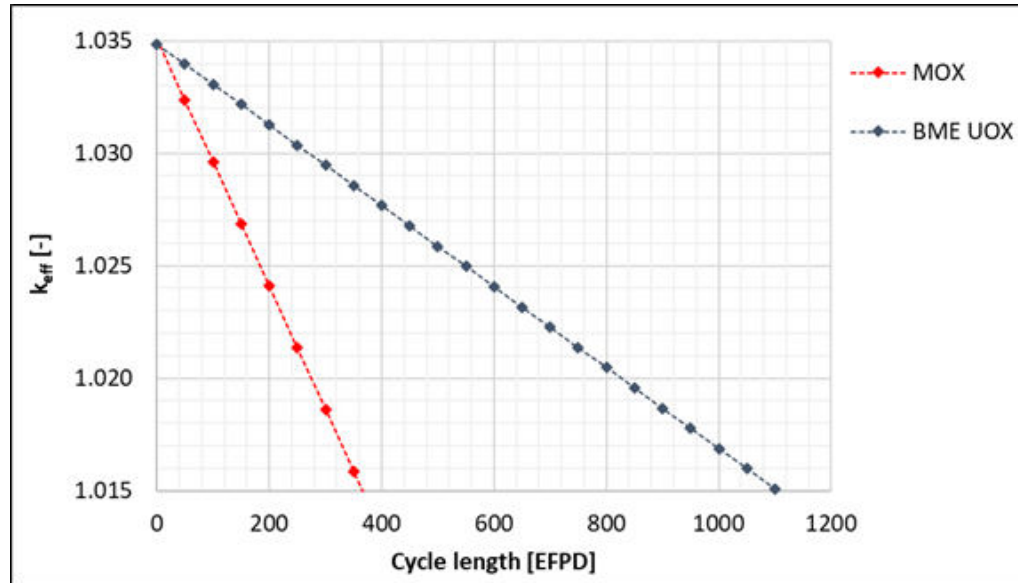

Iterative core design optimization shall be performed for each possible core design:

- MOX core
- UO₂ core
- MOX/UOX + ceramic core
- Full ceramic core

Possible design optimization methods:

- Modification of number of FAs
- CSD/DSD relocation
- Pu concentration/U²³⁵ enrichment profiling
- Modification of FA design
- Modification of absorber device design

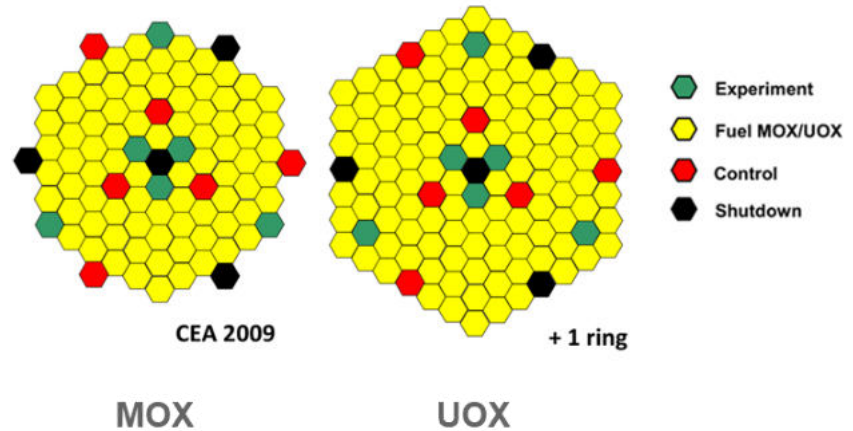

Example: Optimization of MOX core

- Target parameter: maximum assembly power from 1.143 MW → **0.74 MW**
- Total power: kept at **75 MW**
- Volumetric power density decreased by increasing the number of FAs
- k_{eff} at BOC kept at ~ 1.03 by reducing Pu content in some FAs
- Reduced radial power peaking factor → reduce maximum assembly power

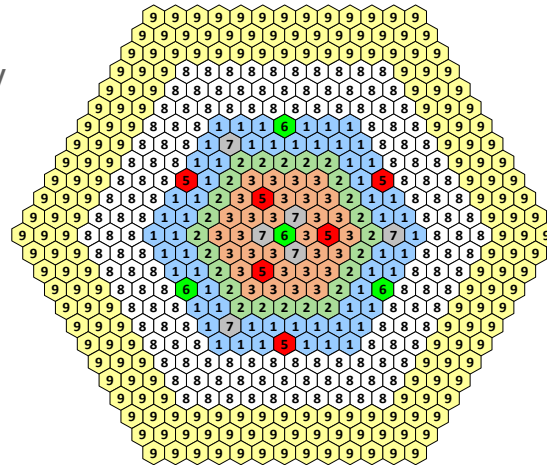

- | | |
|---|----------------------------|
| 1 | Original MOX fuel assembly |
| 2 | fuel assembly -10% Pu |
| 3 | fuel assembly -20% Pu |
| 5 | CSD assembly |
| 6 | DSD assembly |
| 7 | Steel diluent assembly |
| 8 | Radial reflector |
| 9 | Radial shielding |

			STARTING	OPTIMIZED
		unit	CEA 2009	MOX v2
TOTAL POWER		MW	75	75
N° of FUEL ASSEMBLIES		-	81	111
Original / 90% Pu / 80% Pu		-	81/0/0	57/24/30
AVERAGE ASSEMBLY POWER		MW	0.926	0.676
BOC	EXCESS REACTIVITY	pcm	2973.1	2860.0
	CRITICAL CONTROL ROD POSITION (INSERTION OF 6 CSDs)	cm	32.6	34.2
	RADIAL POWER PEAKING FACTOR @ ALL RODS OUT	-	1.236	1.154
	RADIAL POWER PEAKING FACTOR @ CRITICAL ROD POS	-	1.234	1.154
	MAXIMUM ASSEMBLY POWER	MW	1.143	0.780
	FUEL TEMPERATURE REACTIVITY COEFFICIENT @1200K	pcm/K	-0.687	-0.698
	VOID REACTIVITY COEFFICIENT	pcm/void%	0.90	1.14
	CLADDING TEMPERATURE REACTIVITY COEFFICIENT	pcm/K	-0.004	0.007
MAXIMUM DPA RATE IN EXPERIMENTAL POSITION		DPA/year	14.9	10.8
EOC	MAXIMUM BURNUP OF THE CORE	day	462	641
	RADIAL POWER PEAKING FACTOR @ ALL RODS OUT	-	1.235	1.150
	ACCUMULATED MAXIMUM DPA IN EXPERIMENTAL POSITION	DPA	18.9	19.3

- **Inherent safety: smaller reactivity feedback (especially the Doppler coefficient)**
- **Cross section data uncertainties are higher**
- **Higher expansion coefficients (due to higher temperatures) → expansion of structural materials**
- **Complicated design compared to Gen III reactors**
- **Regulatory environment undeveloped in most country → no strict regulations to rely on**

Thank you for your attention!

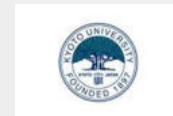

Fast Reactor Modelling and Core Design

Eugene Shwageraus

University of Cambridge

Outline

- Physics of fast reactors
- Simulation strategies
 - Neutronics
 - Accounting for multi-physics effects
- Validation
 - Sensitivity and uncertainty analysis
 - Data assimilation

Fission Cross Sections of Important Nuclides

Thermal neutrons

Resonance neutrons

Fission neutrons

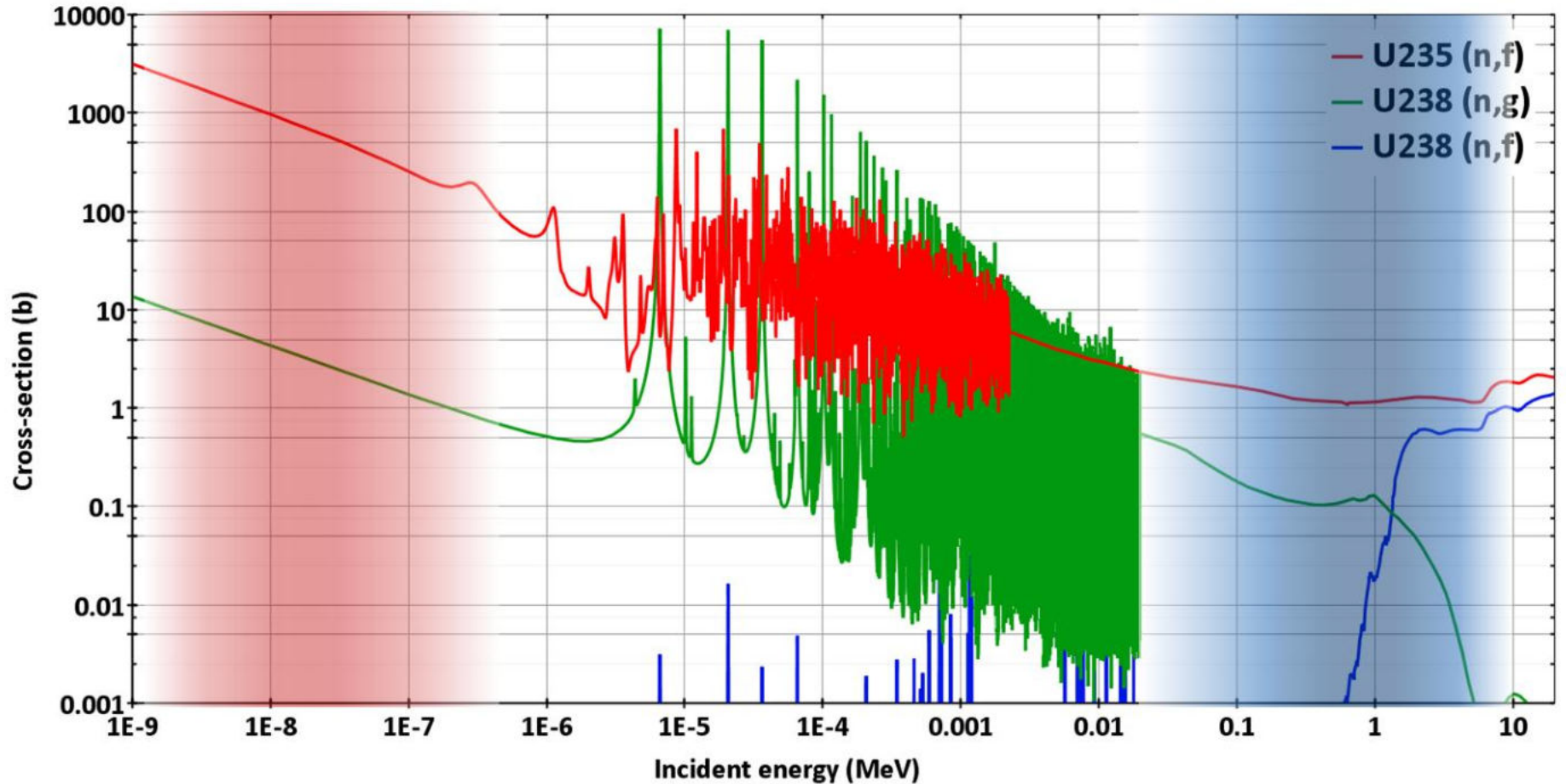

Neutron Spectrum

K. Mikityuk, PSI, 2013

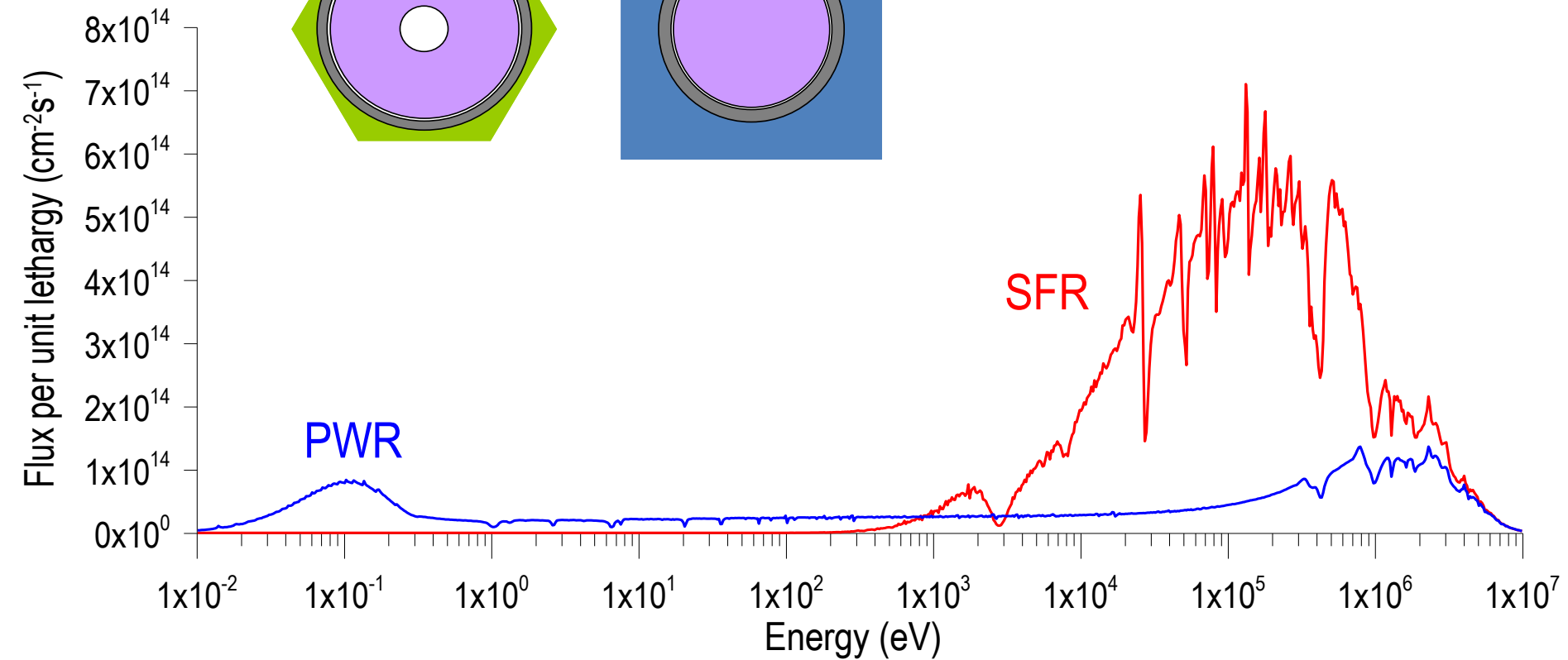
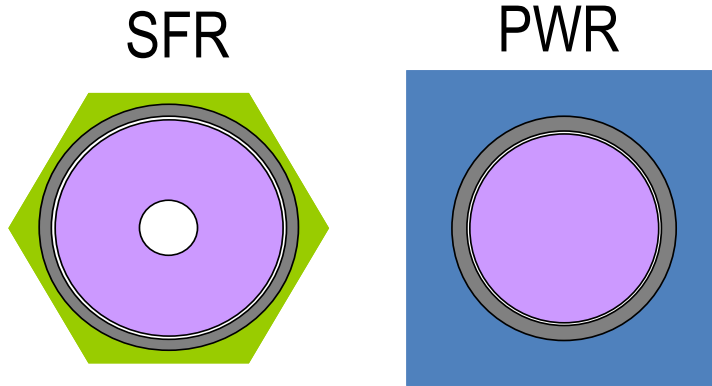

Rationale for Fast Reactors

Abundant neutrons → breeding

→ transmutation

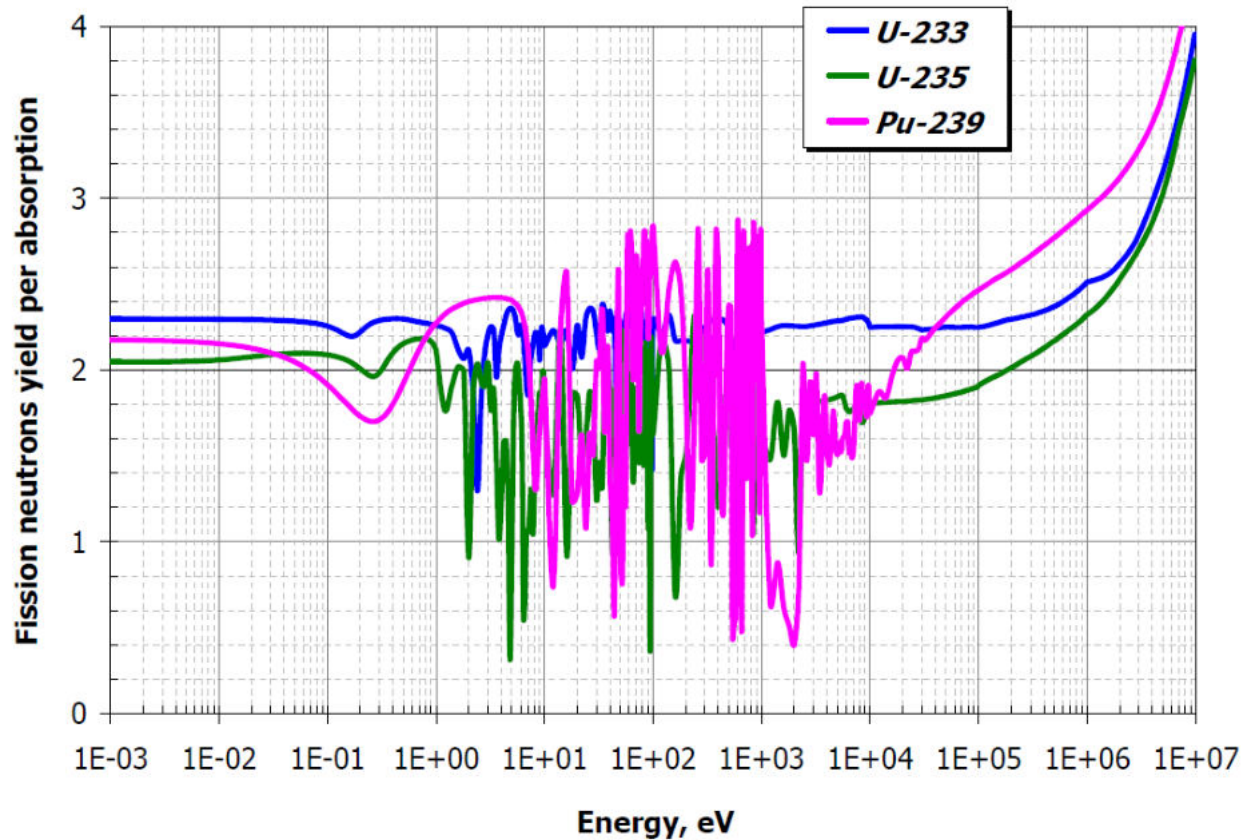

Reactor Doubling Time

- Time to produce enough fissile material to fuel a new, identical reactor
- Initial fissile inventory: m_0
- Fissile material gain per year: \dot{m}_g

$$T_D = m_0 / \dot{m}_g = \frac{2.7 \times m_0}{P \times \bar{G} \times (1 + \alpha)}$$

- To shorten the Doubling Time:
 - High Breeding Gain
 - Small capture to fission ratio
 - Small specific fissile inventory m_0/P (or high specific power W/kg)

Fast Reactor Design Decision Logic

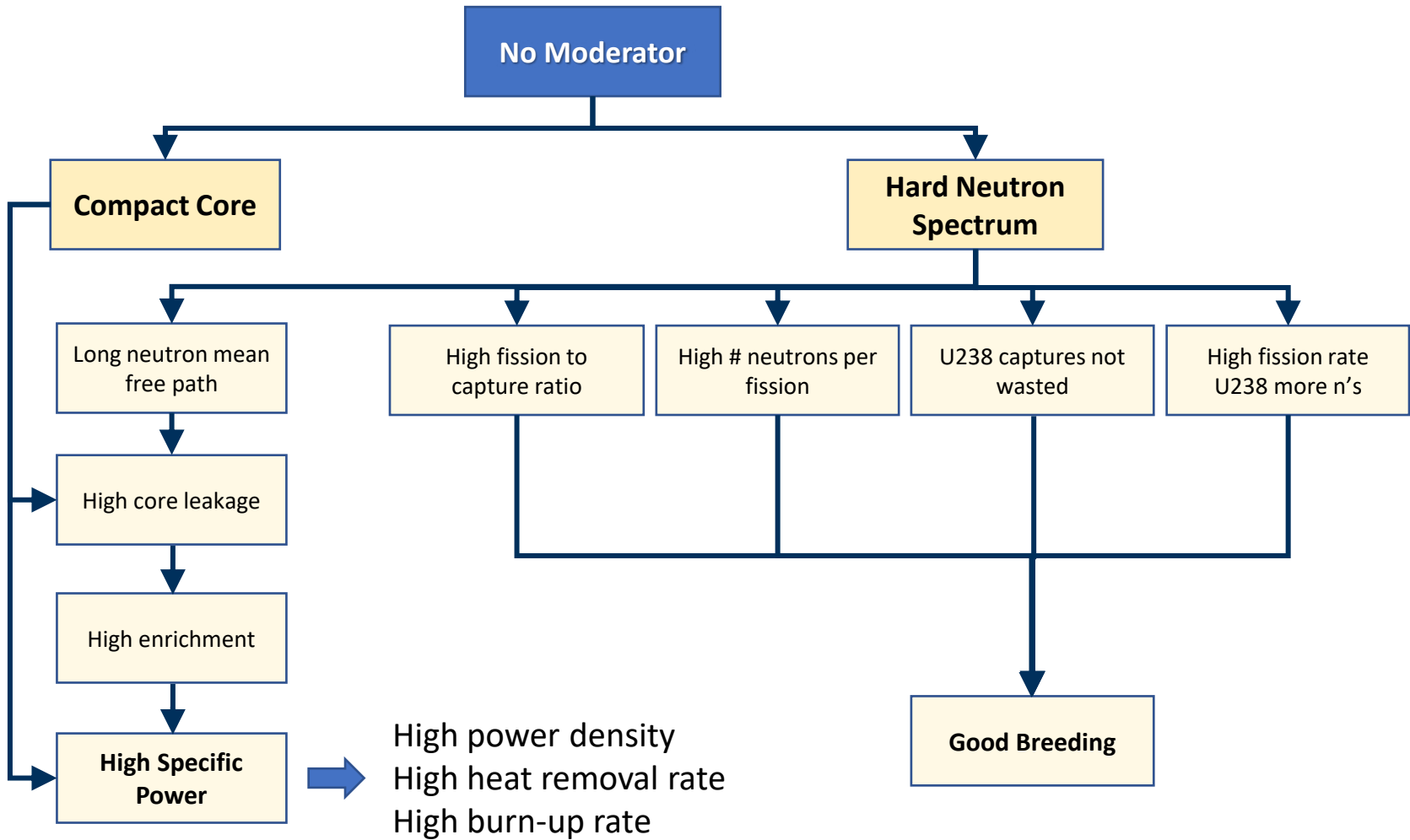

Fast Breeder Reactor design features

- All neutron cross sections are lower at high energies (about $\times 1/10$)
 - The core is more transparent to neutrons \rightarrow High leakage
 - Need higher neutron flux ($\times 10$) for a given power
- Higher enr. and/or HM density is needed for criticality (to keep λ short)
 - 15-20% vs. 3-5% in thermal spectrum
- Radiation damage to structures due to hard spectrum and high flux
 - Typical damage to the clad is 100-200 dpa vs. 1-2 dpa in LWRs
 - Radiation damage (not reactivity) often limits the fuel lifetime
- High power density and burnup are required to compete with LWRs
 - Up to 300 W/cm^3 vs. 100 W/cm^3
 - Over 150 MWd/kg vs. 50 MWd/kg



Fast Breeder Reactor design features

- Fertile blankets (heterogeneous core) are used to capture leaking neutrons
 - High proliferation risk, as nearly weapons grade Pu is generated
 - Recent designs avoid using radial blankets altogether
- Very hard neutron spectrum (many excess neutrons)
 - Minimize coolant volume fraction
 - High density fuel (U-Zr alloy, UN¹⁵, UC)
 - Positive coolant thermal expansion (and void) coefficient
 - Reduced Doppler Coefficient
- Must rely on other reactivity feedbacks for stability and shutdown
 - Leakage is increased with spectrum hardening
 - Core geometry changes due to thermal expansion



Fast Reactor Coolants: Sodium

- Melting point = 97°C → requiring trace heat to avoid freezing
- Na-K eutectic has been used to reduce melting point
- Boiling point = 883°C → boiling to be avoided because of positive void coefficient
- Neutron activation in core → need for secondary circuit

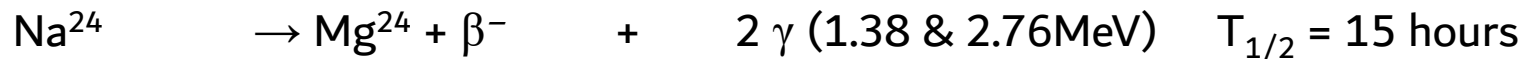
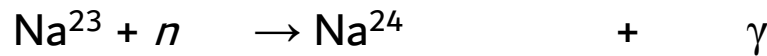

- Compatible with stainless steels, low corrosion
- Potential for reaction with water and release of corrosive products & hydrogen



Fast Reactor Coolant: Lead

- Extremely corrosive
 - Limits flow velocity to **2 m/sec** to maintain protective oxide layer
 - Results in large flow area and low power density (comparable to PWR)
- Chemically and neutronically inert
 - No need for intermediate loop
- High boiling point = 1750 °C
 - No danger of voiding in the core
- High melting point = 327 °C
 - May freeze in overcooling accidents (MSLB)
 - Complicates maintenance
 - Pb-Bi eutectic is used in Russian submarines → Po activation becomes an issue
- High (absolute) thermal expansion → efficient natural convection



Reactivity Feedbacks and Passive Safety

- Mandatory requirement for Gen-IV systems
- Pathways for affecting reactivity
 - Control rods movement
 - Coolant flow rate
 - Heat removal rate (core inlet temperature)
- Limiting accident scenarios – all “unprotected” (failure to scram)
 - Transient over-power (TOP)
 - Loss of Flow (ULOF)
 - Loss of Heat Sink (ULOHS)

Fuel thermal expansion

Driven by increase of fuel temperature

- increase of the fuel column average height
- decrease of fuel smeared density
- more parasitic absorption by clad materials
- more scattering on coolant nuclei
 - negative feedback
- slight insertion of control rods
 - negative feedback
- increase of leakage in radial direction
 - negative feedback

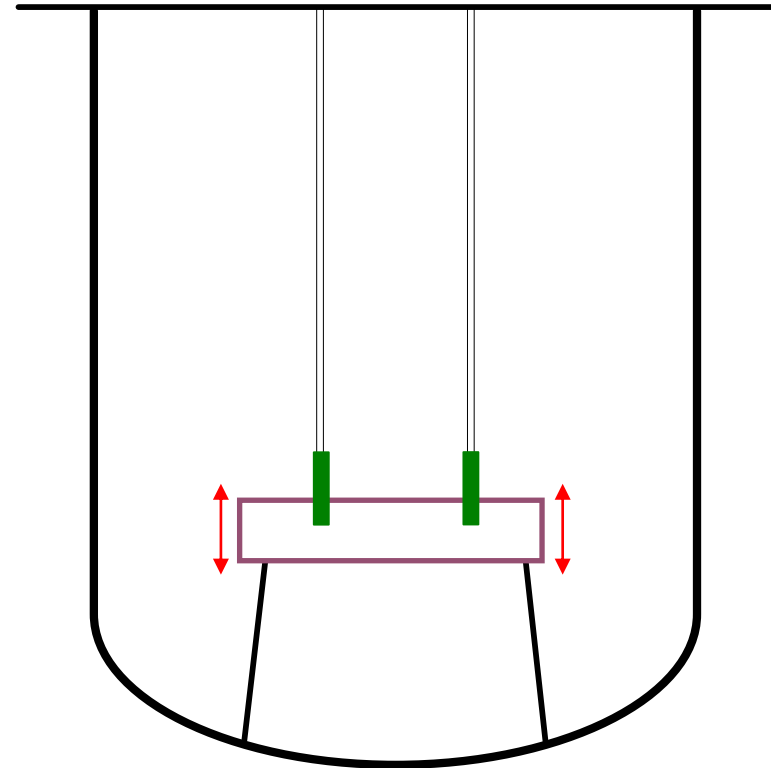

Clad thermal expansion

driven by increase of cladding temperature

- thermal expansion in axial and radial direction
- increase of the cladding average height
- less parasitic absorption by clad materials
 - positive reactivity feedback
- increase of the cladding average radius
- less coolant (pushed out by clad)
- effect similar to coolant expansion
 - positive reactivity feedback

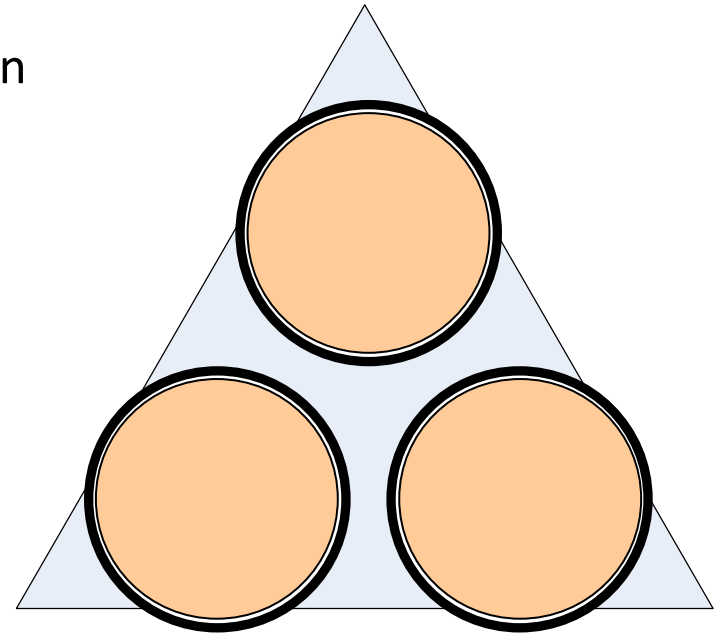

Core grid plate thermal expansion

driven by increase of coolant T @ core inlet

- core thermal expansion in radial direction
- increase of the effective core radius
- increase of leakage
 - negative reactivity feedback
- gaps between fuel subassemblies increase
- increase of the coolant volume fraction
- more scattering
- spectrum softening
 - negative reactivity feedback

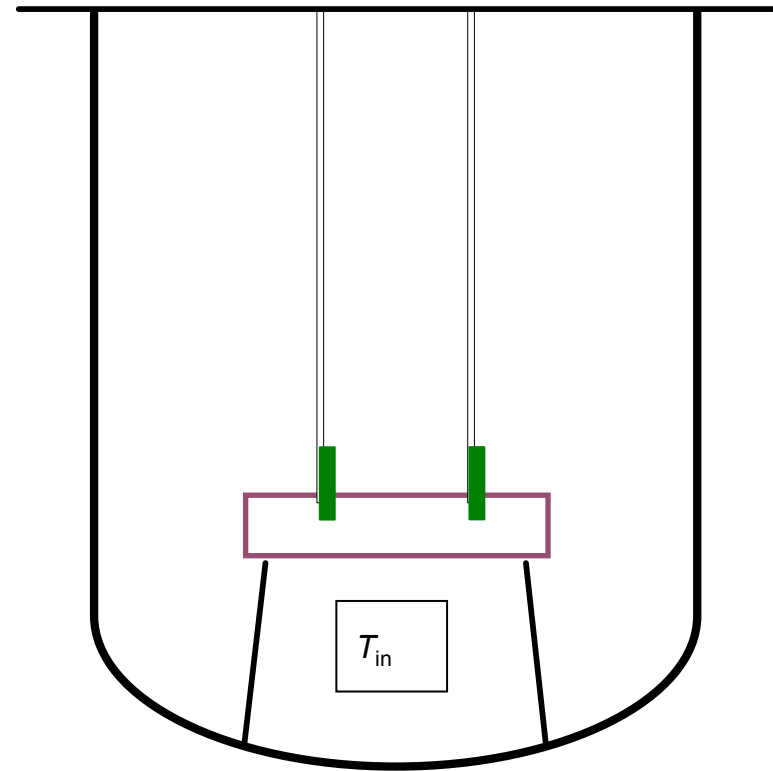
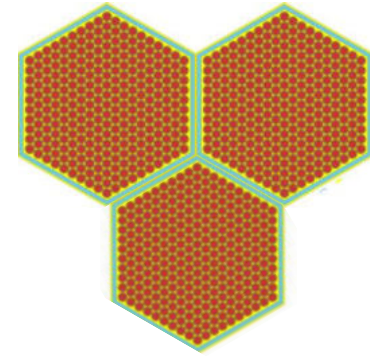

Core support thermal expansion

driven by increase of coolant T @ core inlet

- thermal expansion in axial direction
 - the whole core is slightly shifted up
 - control rods are slightly inserted
- negative reactivity effect

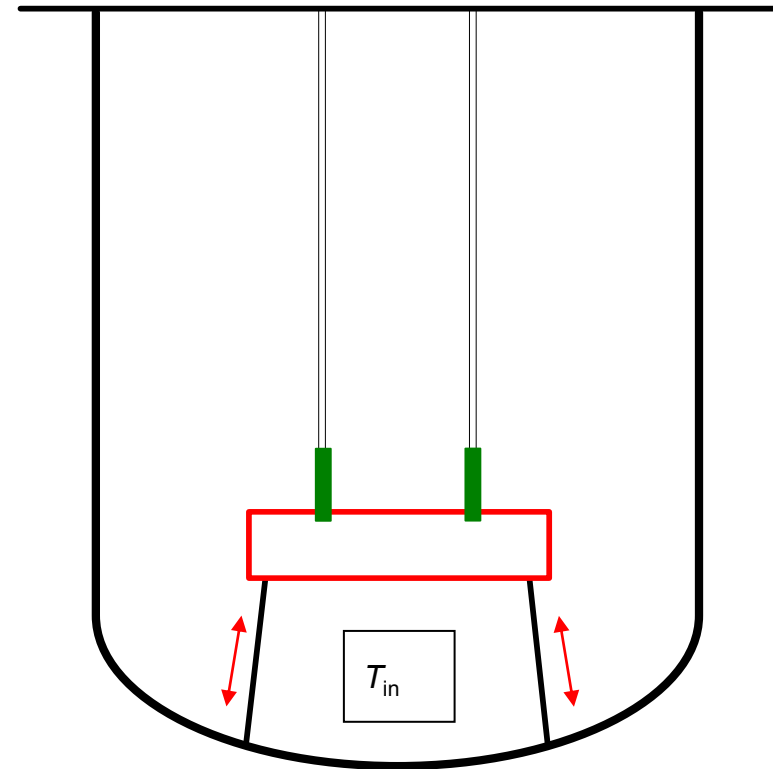

Vessel thermal expansion

driven by increase of coolant T @ core inlet

- vessel expansion in axial direction
- the whole core is slightly shifted down
- control rods are slightly withdrawn

→ positive reactivity effect

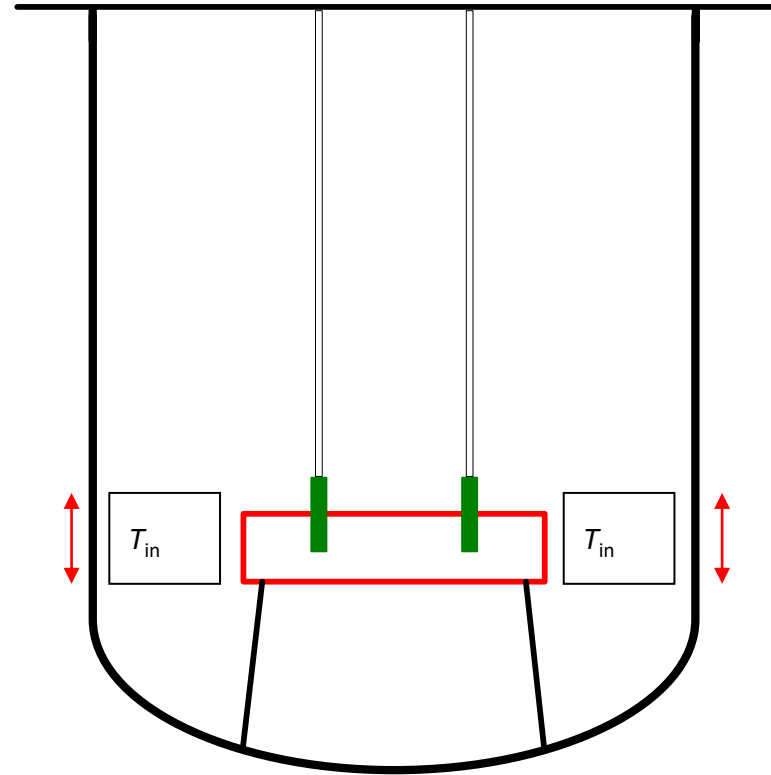

CR driveline thermal expansion

driven by increase of coolant T @ core outlet

Heating up of the control rod drivelines:
their thermal expansion in axial direction
control rods are slightly inserted

→ negative reactivity effect

The “skirt” above the core helps to stream
the hot coolant towards the CR drives

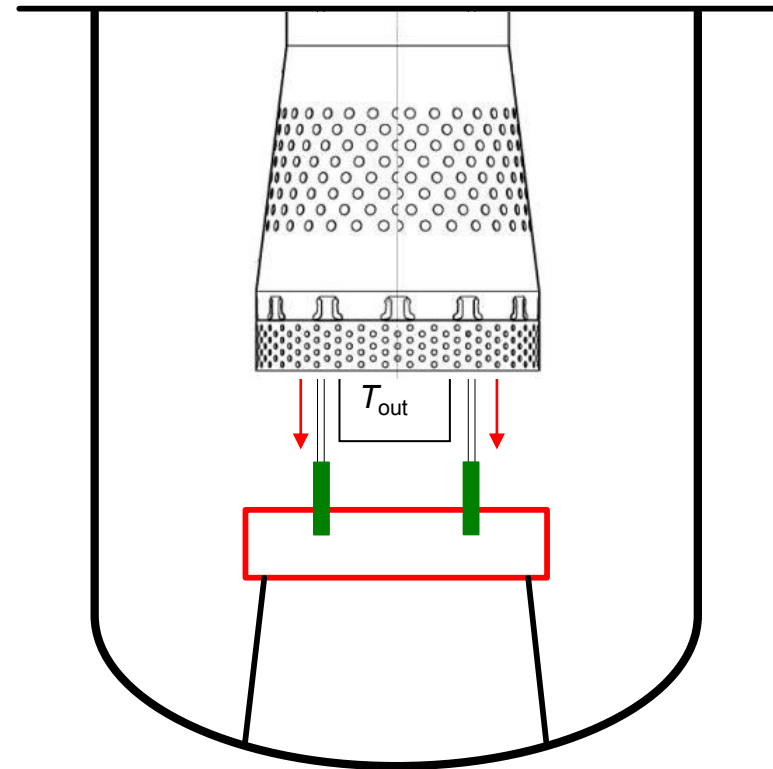

Simulation of Fast Reactors

Monte Carlo

- Direct full core
 - Computationally expensive
 - Coupling with multi-physics is not well developed
 - Reactivity feedbacks are small, high statistics required
 - Not practical for transient analysis
- Two-step process (like LWRs)
 - Generate homogenised cross sections for representative fuel lattice
 - Parametrise against operating conditions
 - Use in a full core (diffusion) simulator with feedbacks

Simulation of Fast Reactors

➤ Deterministic transport

- Long MFP → Diffusion works reasonably well
- Transport effects → reflectors, control rods, voiding
- 3D full core transport (MoC, 2+1D) possible
- Homogenisation fails at interfaces with reflectors, control rods
 - Super-cells with Discontinuity Factors/SPH
 - More energy groups
 - Capture multi-physics effects at XS level is a challenge
 - Especially thermal expansion

Traditional approach to neutronic modelling



Basic data base:

- cross-sections
- decay chains
- energy per int.
- fission yields

- Too many dimensions in TE to brute-force all at once
- TE coefficients are not constant
- need multi-physics feedbacks

Multi-group cross sections

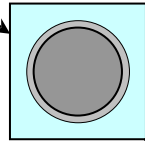

Unit cell
1D transport of equivalent cell

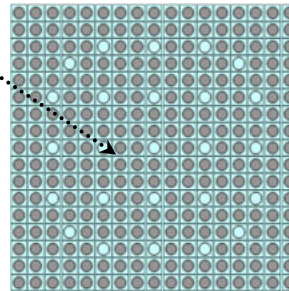
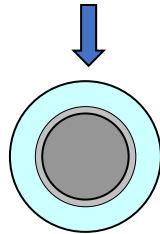

Fuel assembly
2D transport or diffusion

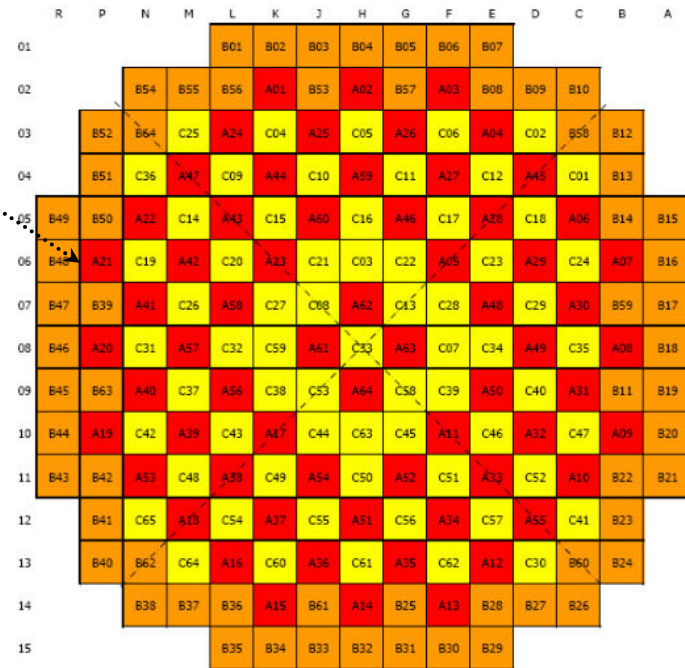

Reactor core

3D diffusion

Two-step process example

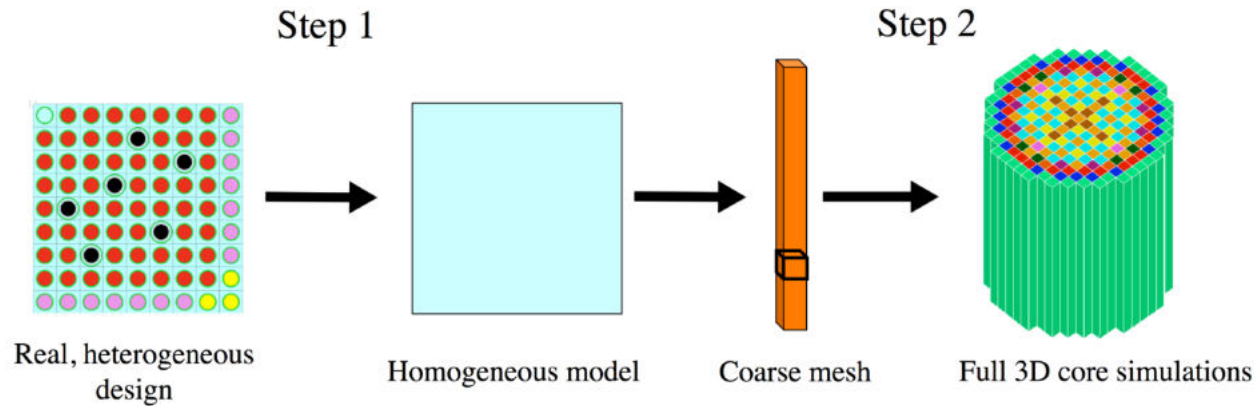

Supercell

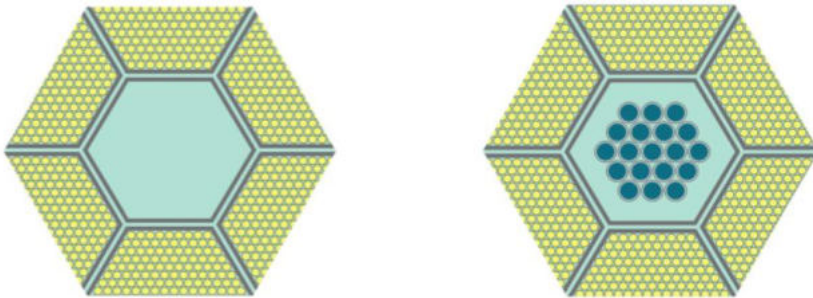

SPH Process

$$T_{RR}^{Het} = T_{RR}^{Hom}$$

$$\sum_{h \in G} \sum_{r \in R} V_r \bar{\phi}_{r,h}^{Het} \Sigma_{r,h} = \sum_{h \in G} \frac{\sum_{r \in R} V_r \phi_{r,h}^{Hom} \mu_{r,h} \Sigma_{r,h}}{N_h}$$

Modelling thermal expansion

- Parametrise XS vs lattice dimensions
 - Limited applicability, effects are greatly simplified
- Weighted mixing of neighbouring nodal XS
 - Successfully shown to capture axial fuel and diagrid expansion
- Perturbation theory
- Virtual Density method (M. Reed et al. 2014)
 - Equivalence between geometry distortion and density
 - For $\rho = \text{const}$, $\lambda \propto V^{1/3} \rightarrow N \propto V^{-1/3}$

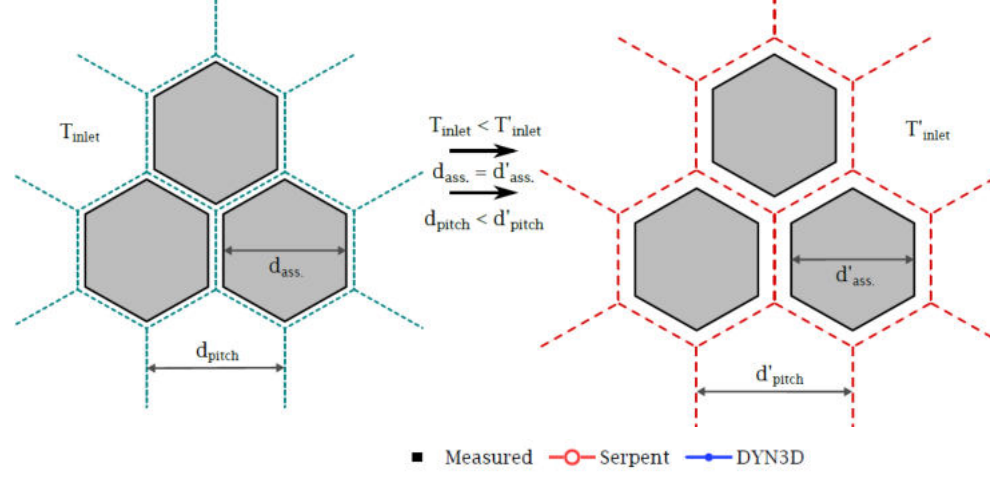
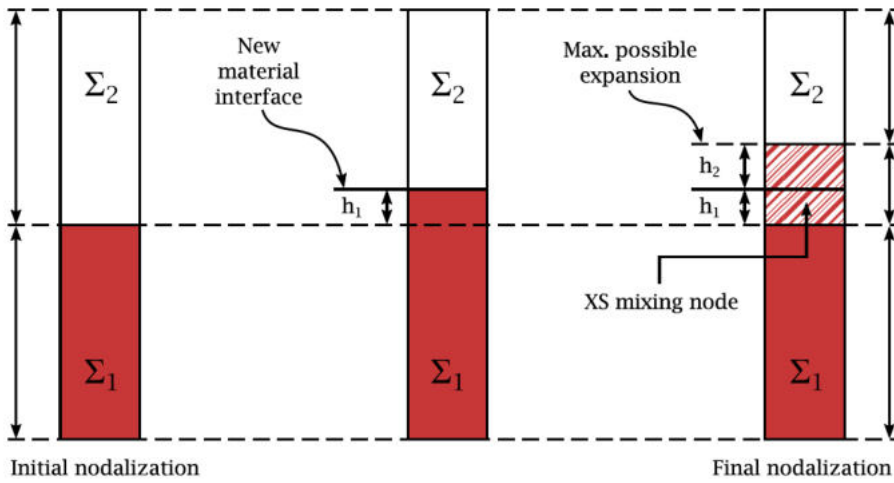

$$\Sigma_{\text{mixed}} = \frac{h_1 \Sigma_1 + h_2 \Sigma_2}{h_1 + h_2}$$

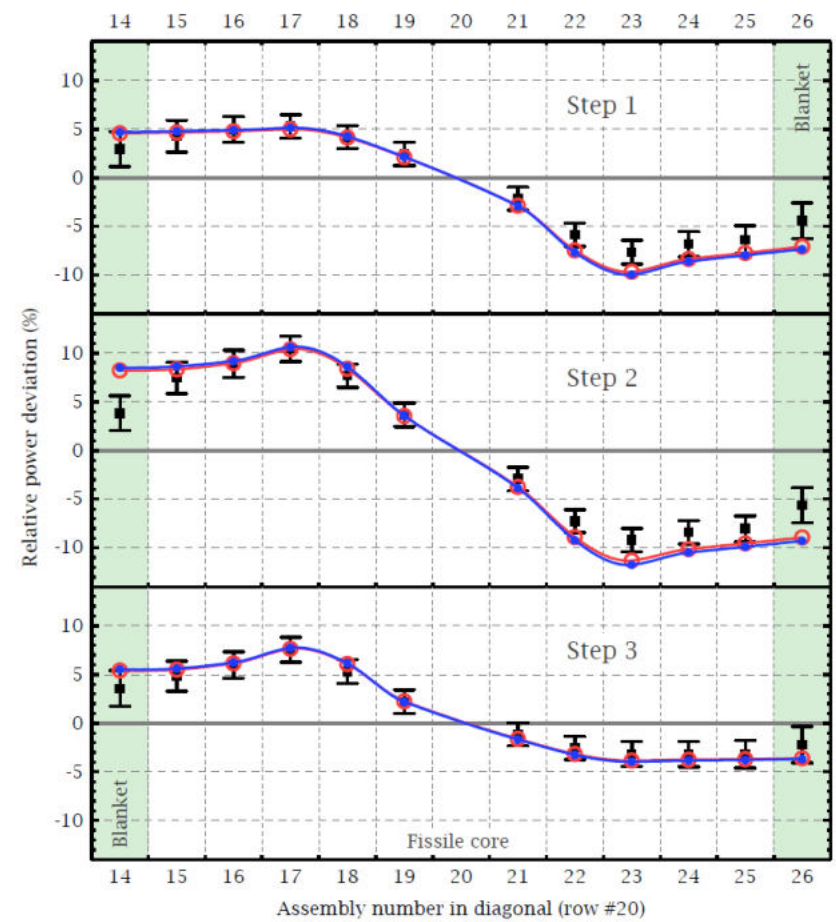
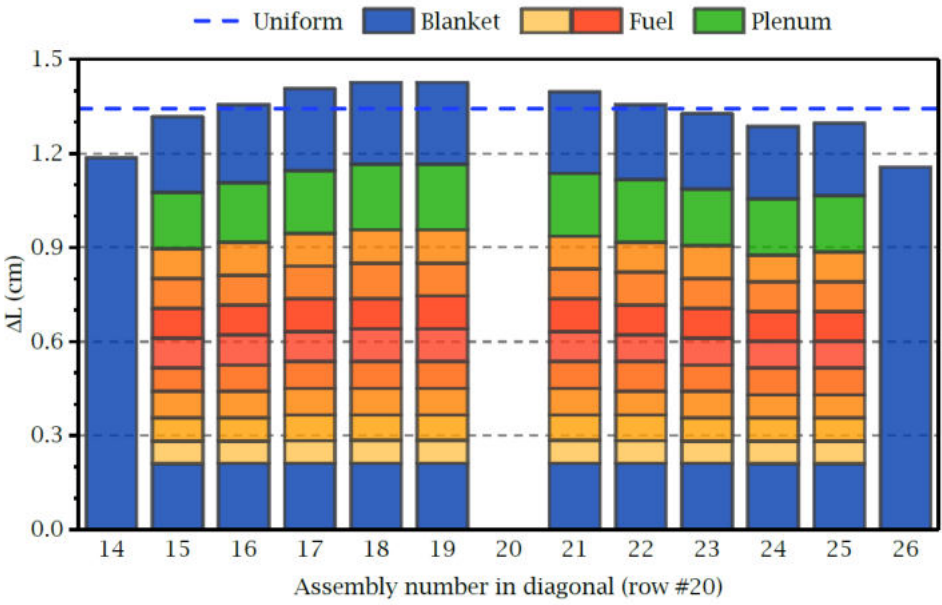

- Coupled 2D or 3D transient analysis of full core and/or primary loop
- Solves for:
 - ✓ **Neutronics** (multi-group diffusion)
 - ✓ **Coarse/fine mesh thermal hydraulics**
 - ✓ **Subscale fuel temperature field** (coarse mesh)
 - ✓ **Thermal mechanics**
- Implicitly coupled
- Three independent unstructured meshes
- Adaptive time step

```
fvm::ddt(IV, flux[energyI]) -
fvm::laplacian(D, flux[energyI]) -
fvm::Sp(nuSigmaFis[energyI]/keff*
        (1.0-Beta)*chiPrompt) -
        sigmaDisapp, flux[energyI]) -
delayedNeutroSource*chiDelayed-
scatteringSource
```

```
fvm::ddt(rho, U)
+ (1/porosity)*fvm::div(phi, U)
+ turb.divDevRhoReff(U)
- porousMedium.
  semiImplicitMomentumSource(U)
```

```
fvm::d2dt2(Disp) ==
fvm::laplacian(2*mu + lambda, Disp,
"laplacian(DD,D)") + divSigmaExp
```

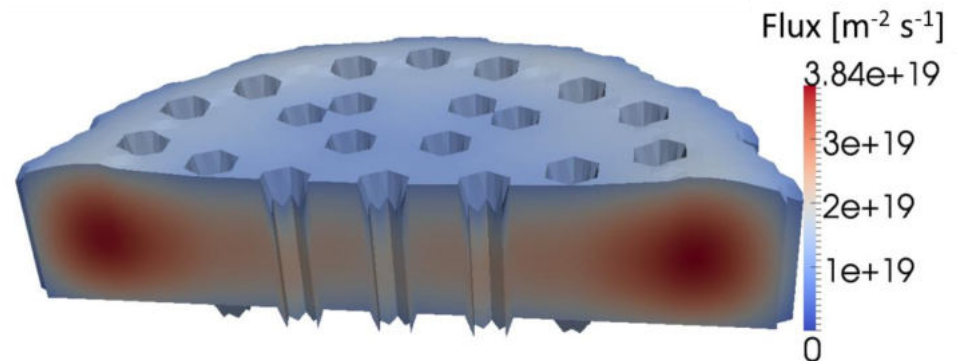
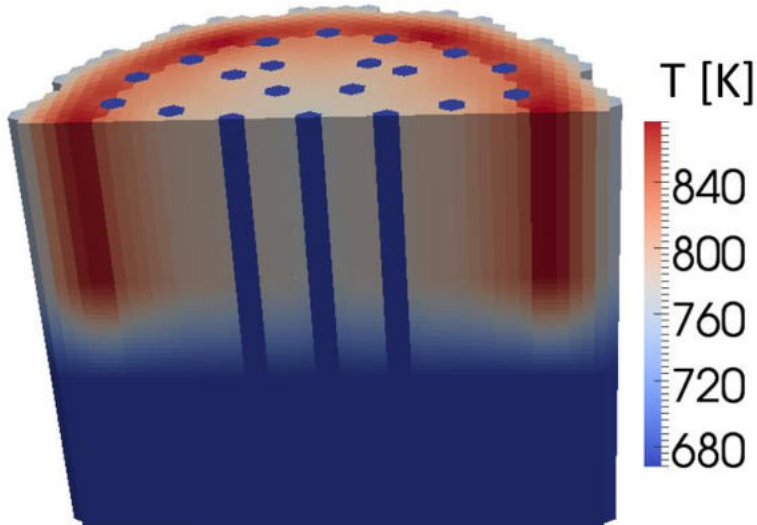

ESFR 3D core analysis

- Example of **coarse mesh** for core analysis, **coupled with neutronics, thermal-mechanics and fuel/clad subscale temperatures** – TRANSIENT (protected channel blockage)

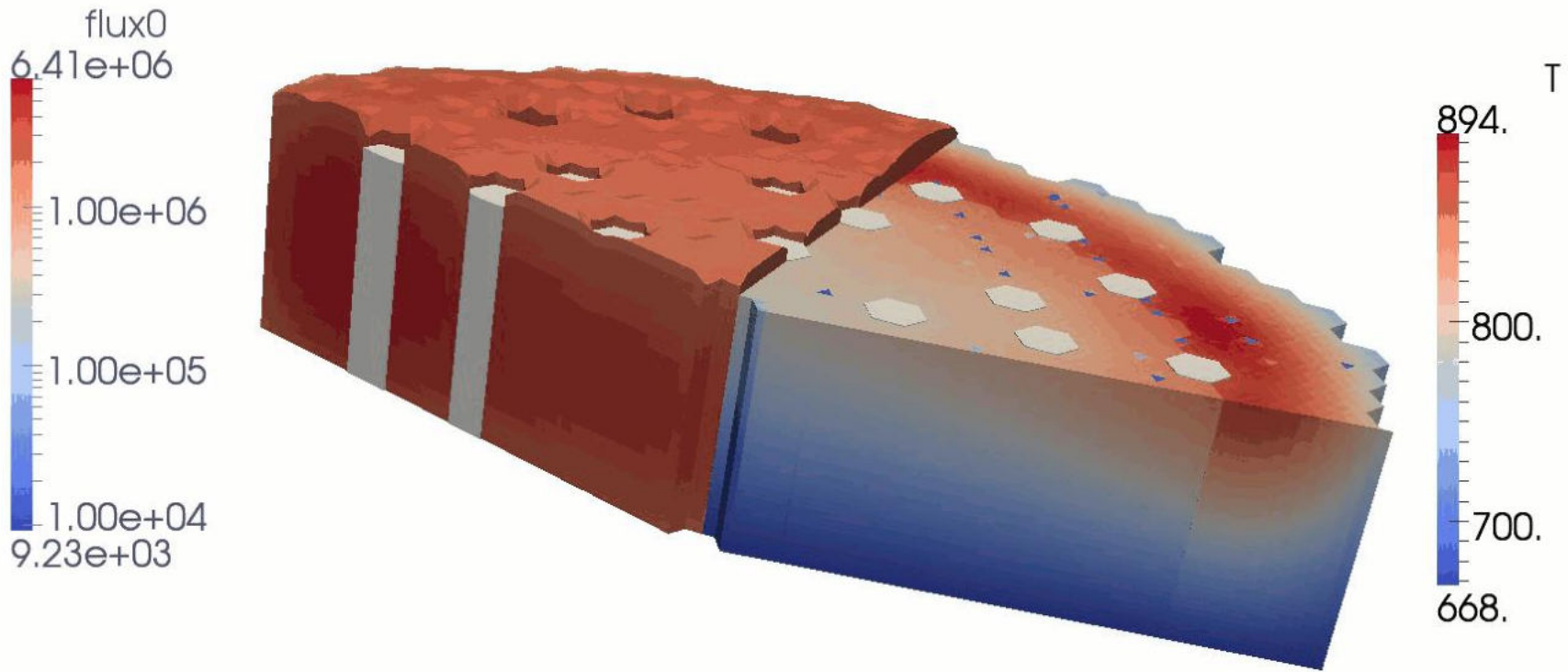

Phenomena to consider in fuel design

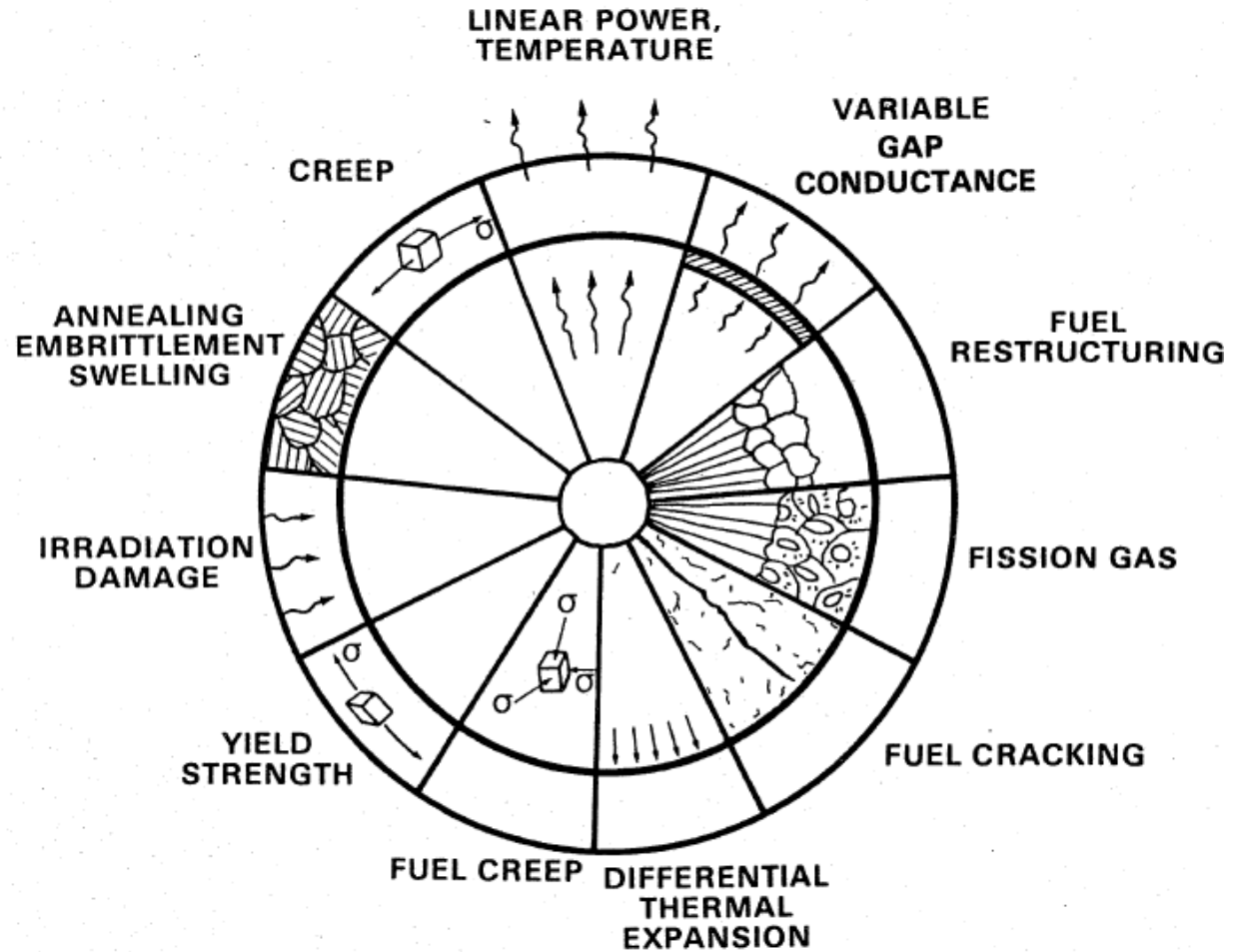
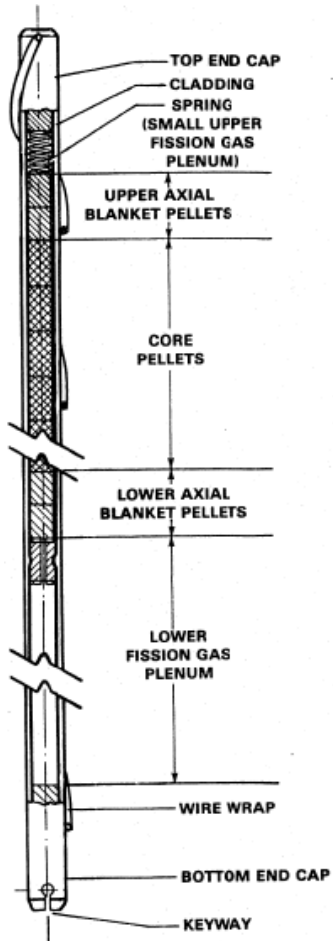

Gap thermal conductance

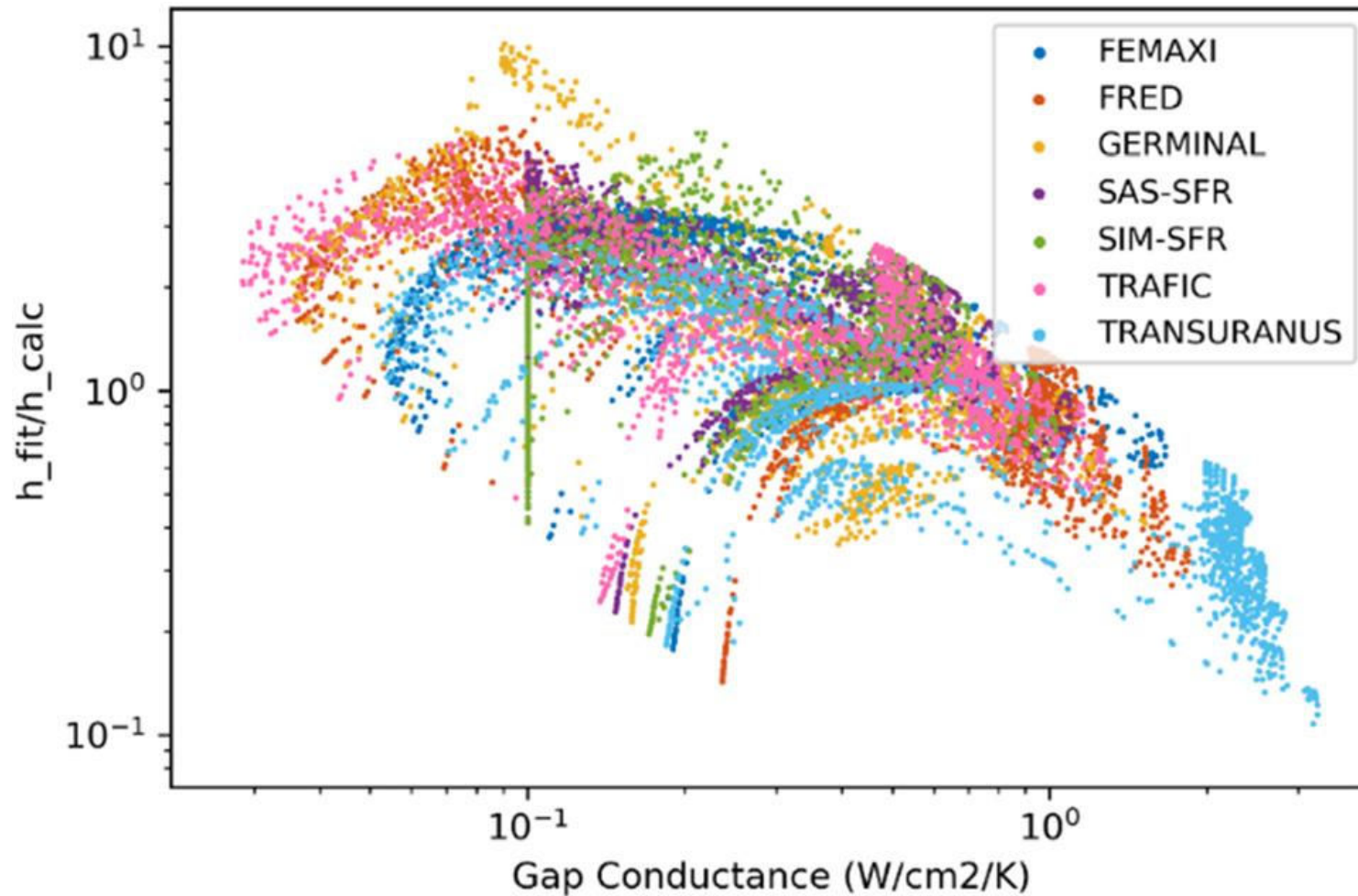

Fuel outer temperature

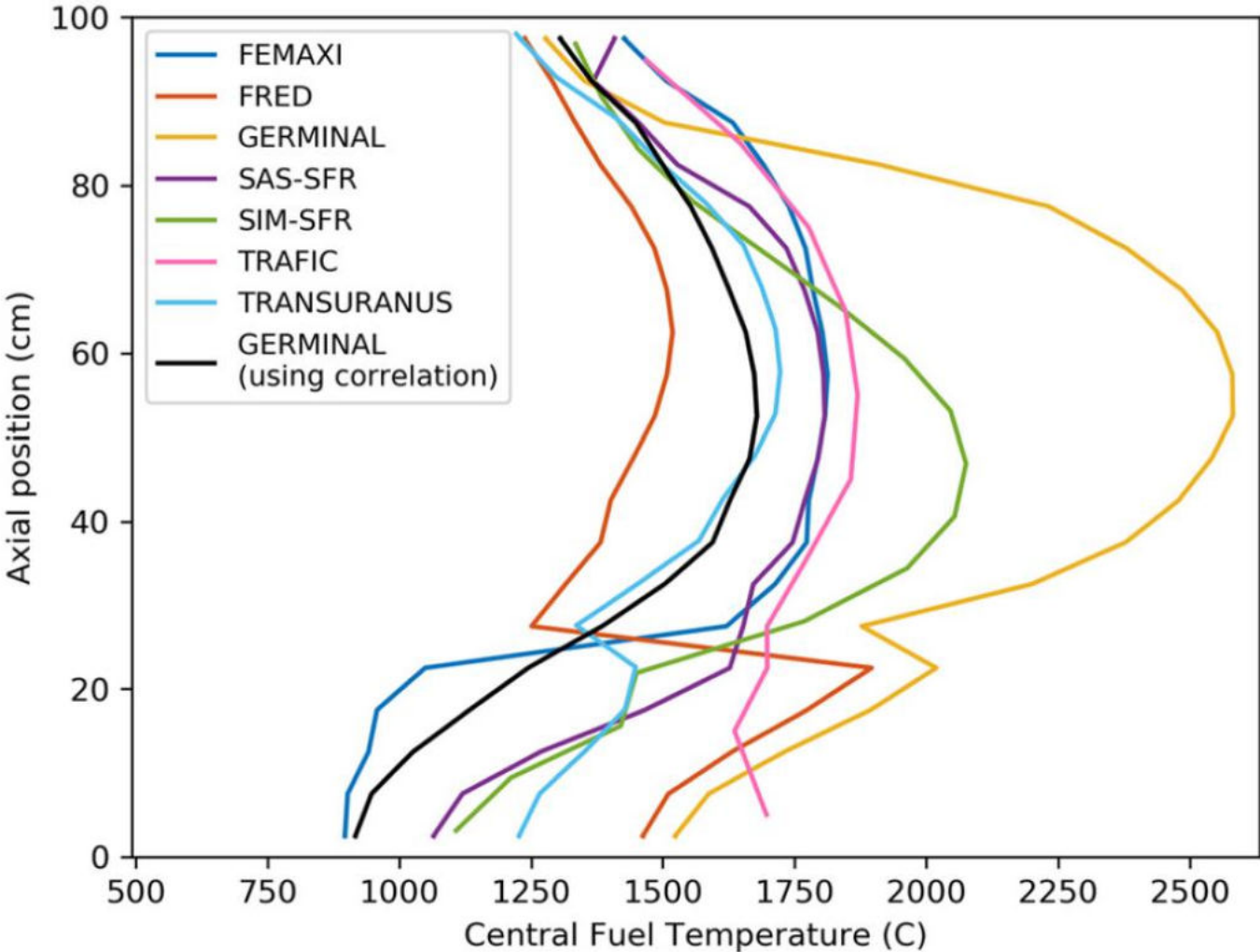

Modelling and simulation

- Needed for design, performance optimisation, safety case
- Models require validation
- Desire for reliability leads to model complexity
- Complexity implies too many validation experiments required
- Experiments are expensive
- Need to prioritise effects
- Need a framework for assimilating new information

Propagation of uncertainties

$$y = f(x)$$

$$\bar{x} = \{x_1, \dots, x_m\}$$

$$\frac{dy}{dx} = \frac{df(x)}{dx}$$

$$\bar{R} = \{R_1, \dots, R_n\}$$

$$x \rightarrow R$$

$$\Delta y \approx \frac{df}{dx} \Delta x$$

$$S_x^R = \frac{dR/R}{dx/x}$$

$$C_y = S_{x/y} C_x S_{x/y}^T$$

Covariance matrix

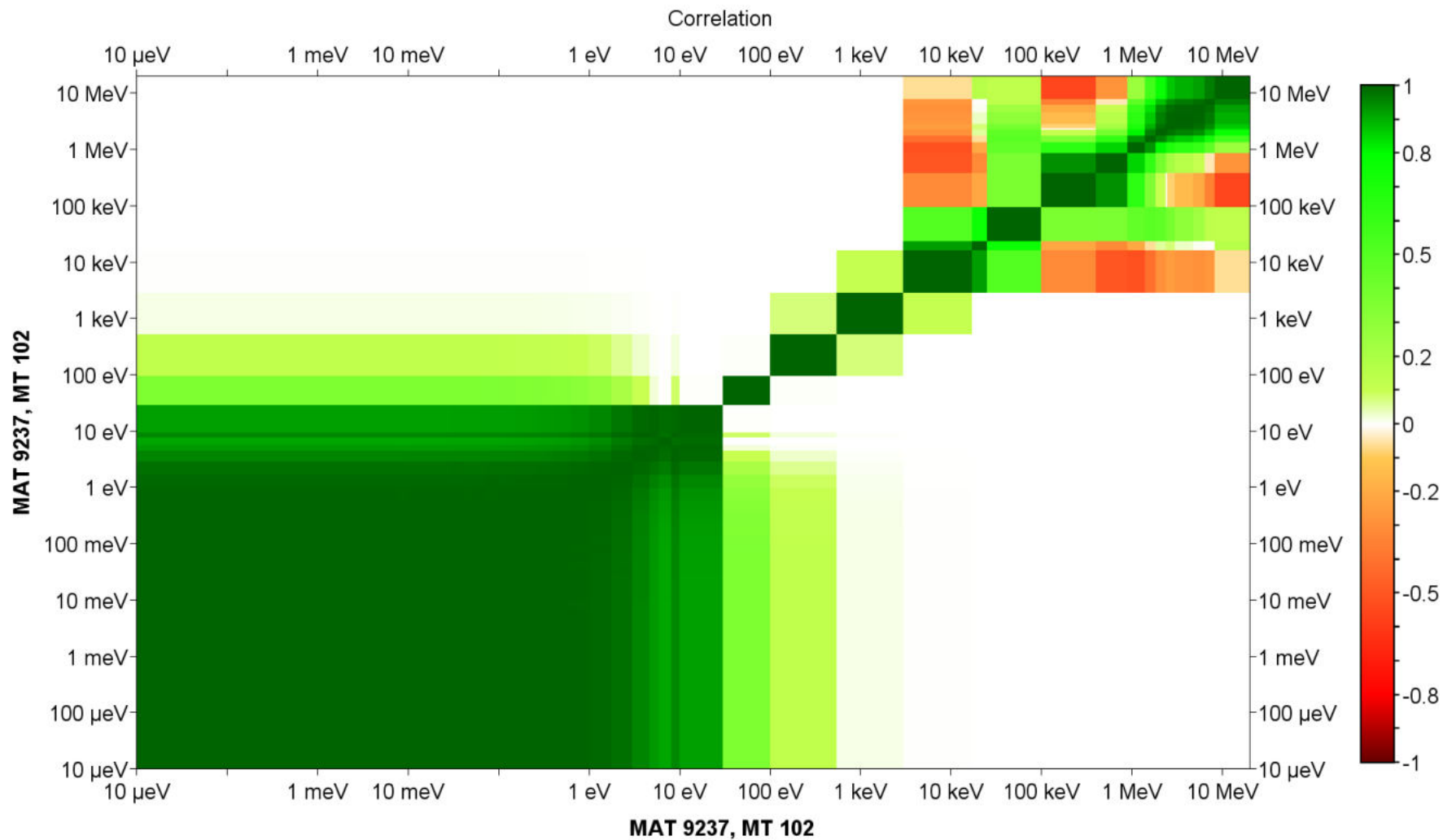

Relation between sensitivity and uncertainty

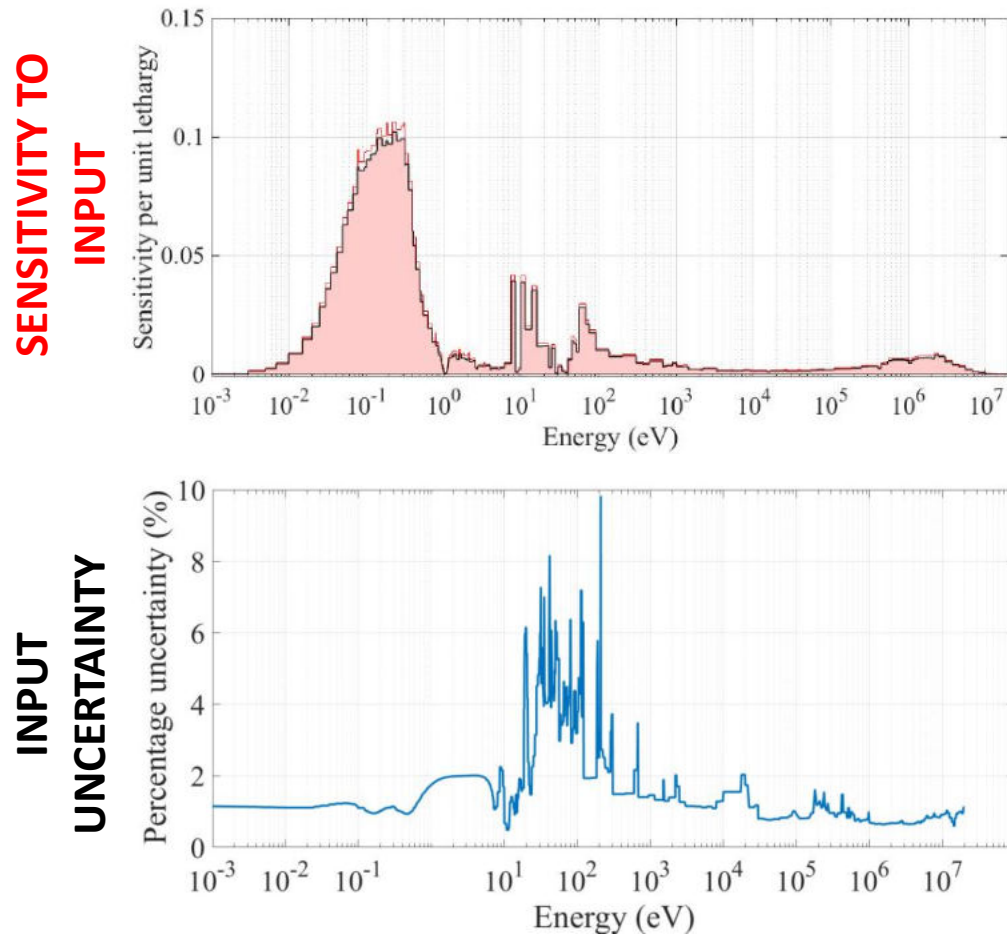

Relation between sensitivity and uncertainty

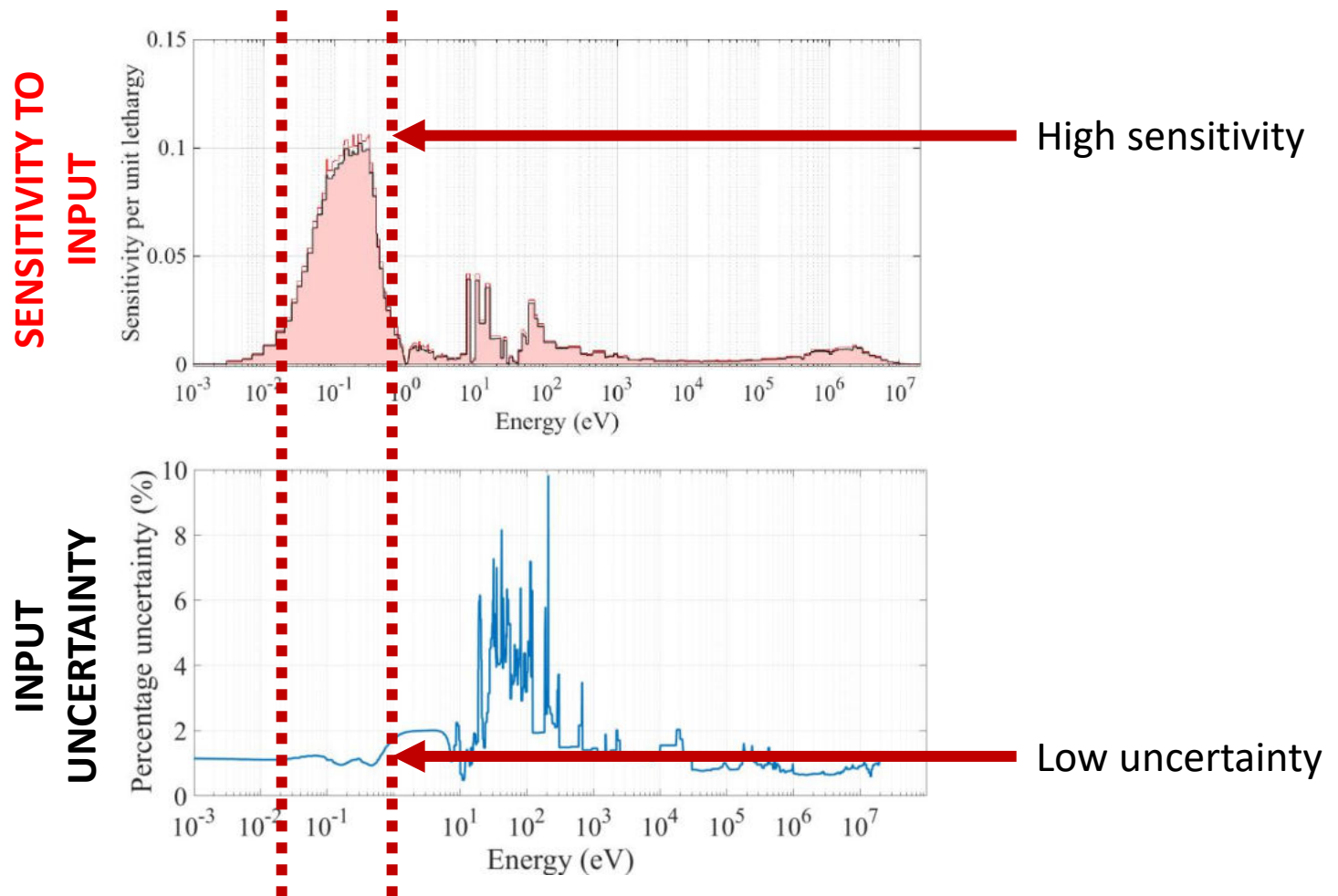

Relation between sensitivity and uncertainty

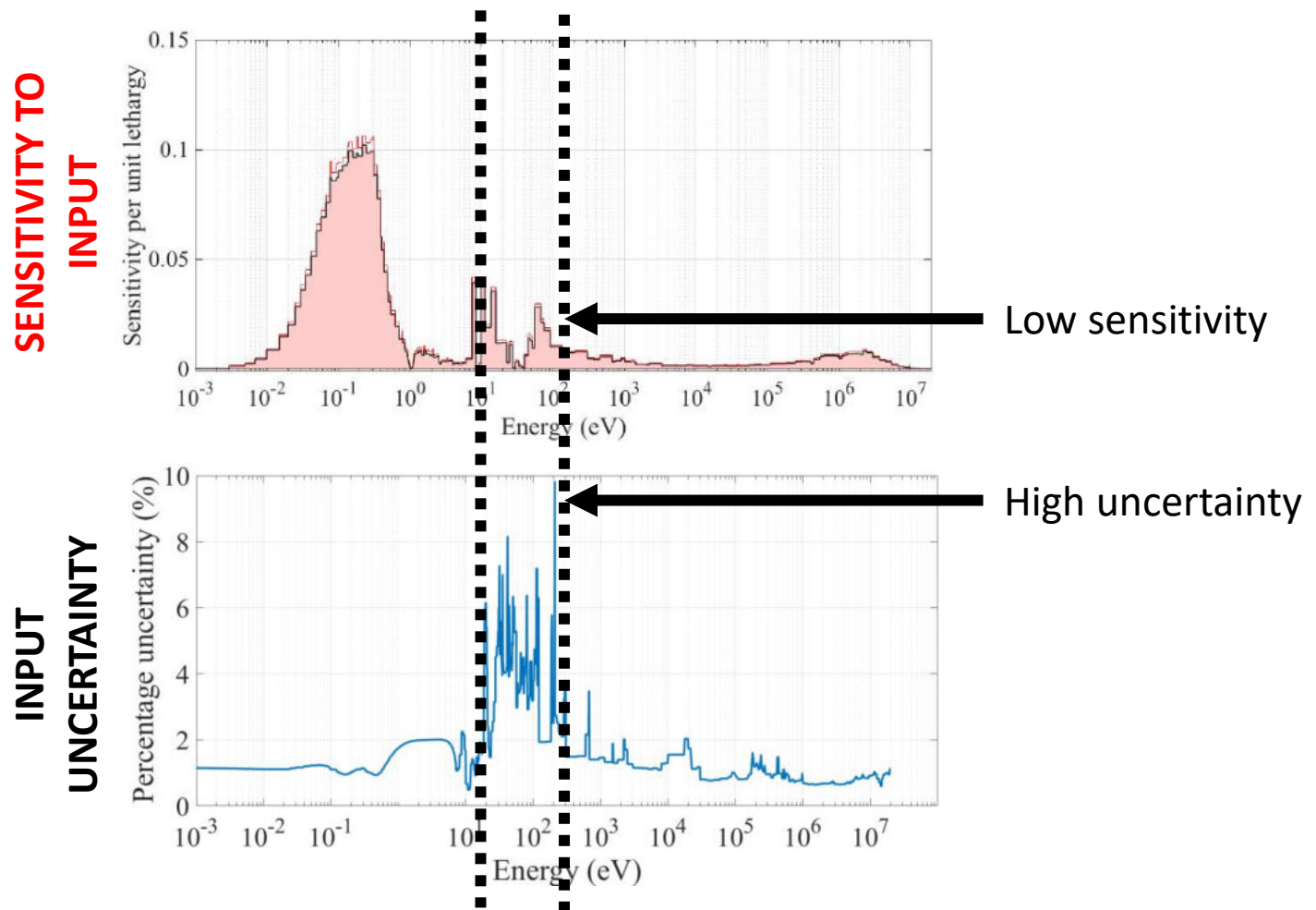

Estimation of validation domain

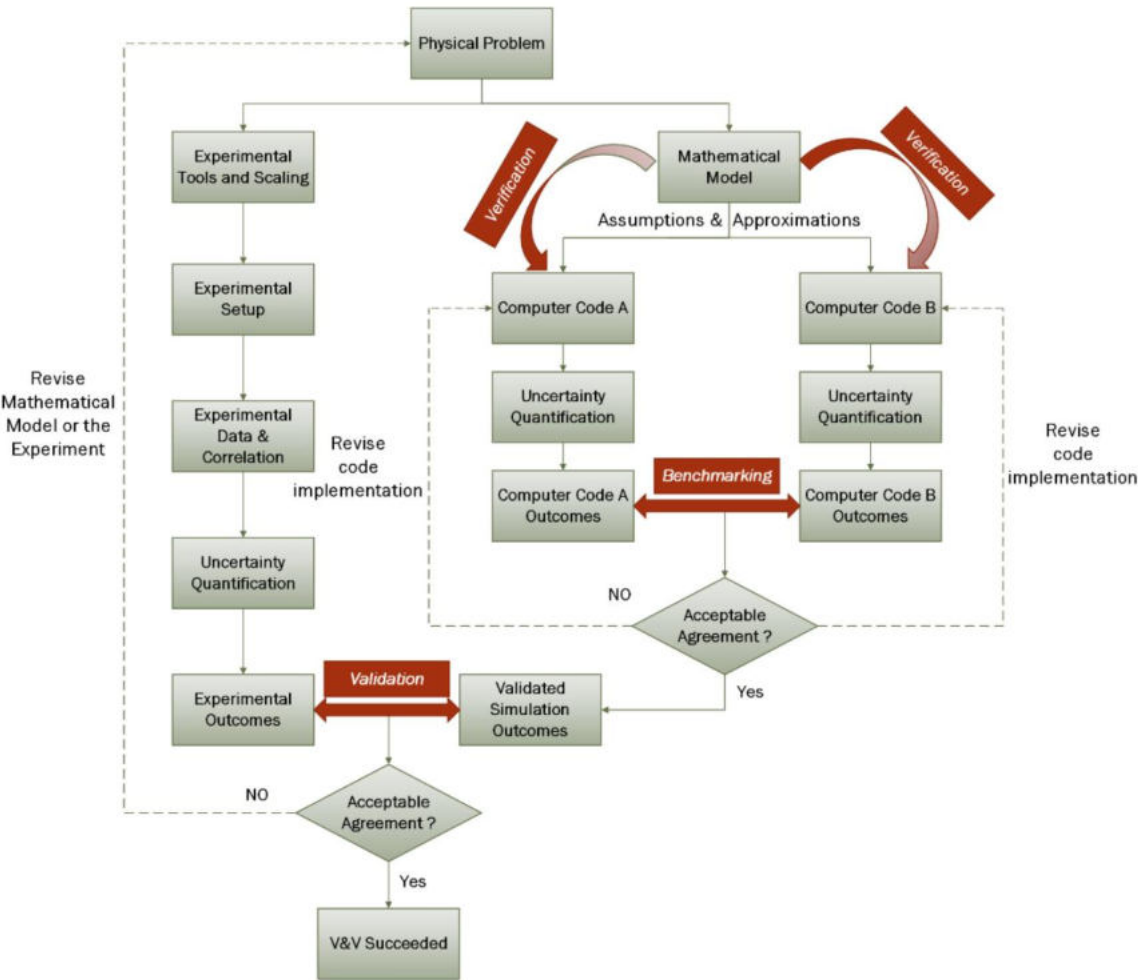

- Uncertainty Quantification
- Verification
- Validation
- Validation required for assuring reliability of models

Data assimilation for reducing uncertainties

Monte Carlo Bayesian Techniques

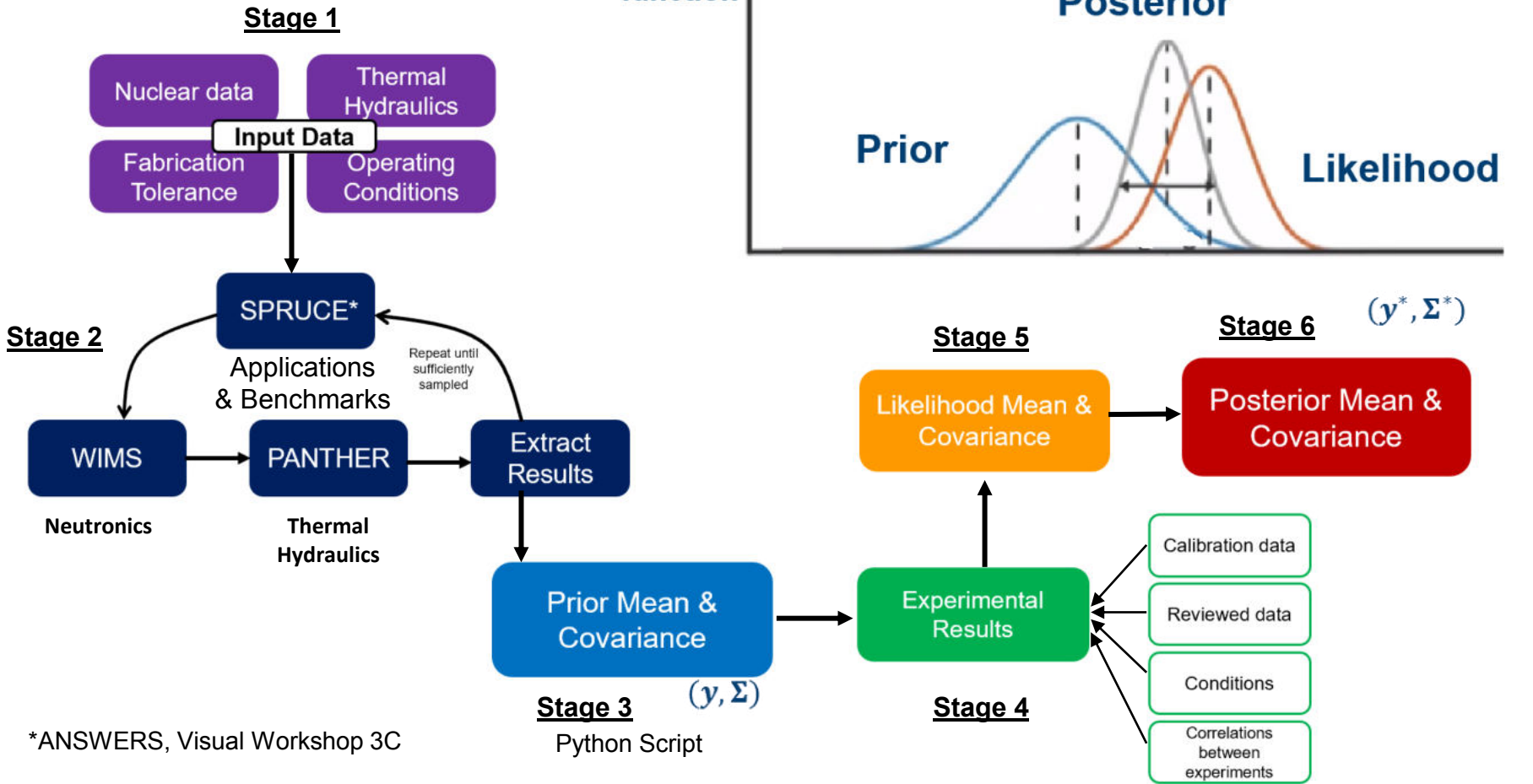

*ANSWERS, Visual Workshop 3C

Thank you!

Questions?

GFR Summer School: Fuel cycle of fast reactors and proliferation resistance

Jan Uhlíř
Research Centre Řež
August 30, 2022



This project has received funding from the Euratom H2020 programme
NFRP-2019-2020-06 under grant agreement No 945041.

Content

- 1 Idea of Fast Reactors**
- 2 Fast Reactors in Generation 4**
- 3 Reprocessing technologies suitable for FR**
 - 2.1 Hydrometallurgical processes
 - 2.2 Pyrochemical processes
- 4 Proliferation resistance and physical protection (PRPP)**
- 5 Fuel cycle of GFR Allegro and PRPP aspects**
- 4 Conclusion**

The original idea of Fast Reactors

Original idea and vision – **Fast Breeder Reactor (FBR)** with closed fuel cycle

The rapid development of nuclear power will be limited in the future by the shortage of uranium.

Fast breeder reactors and a closed fuel cycle will solve this problem.

In addition, the use of plutonium as fissile material will reduce or even eliminate the need for uranium enrichment.

FBRs have been referred to as LMFBRs (Liquid Metal Fast Breeder Reactors), referring primarily to sodium-cooled reactors.

Intensive development of LMFBR took place mainly in the UK, USA, France and the Soviet Union.

Later, other countries were added: Italy, Germany, Japan, China, India,

The original idea of Fast Reactors – cont.

IAEA Bulletin from 1984:

Fast breeder reactors in operation, under construction or planned

Country	Unit name	Power (MWth/ MWe)	Startup date
<i>Operational</i>			
USA	EBR-II	62.5/20.0	1963
USSR	BOR-60	60/12	1969
USSR	BN-350	1000/150*	1972
France	Phénix	605/270**	1973
USSR	BR-10***	10/0	1973
UK	PFR	670/250	1974
Germany, Fed. Rep.	KNK-II	58/21	1977
Japan	Joyo	100/-	1977
USSR	BN-600	1470/600	1980
USA	FFTF	400/-	1980

Under construction

France	Superphénix I	3000/1242	1985
Germany, Fed. Rep.	SNR-300	762/327	1986
India	FBTR	42/15	1985
Italy	PEC	118/-	1989
Japan	MONJU	714/280	1991

Planned

France	Superphénix II	3600/1500
Germany, Fed. Rep.	SNR-2	3420/1300
India	PFBR	1250/500
Japan	DFBR	2550/1000
USSR	BN-800	2100/800
USSR	BN-1600	4200/1600
UK	CDFR	3300/1250

The original idea of Fast Reactors – cont.

Schneller Natriumgekühlter Reaktor SNR-300



Superphénix



Current status of Fast Reactors



Reactor	Type, coolant	Power, MW thermal/elec	Fuel (future)	Country	Notes
BOR-60	Experimental, loop, sodium	55/10	oxide	Russia	1969-2020s
BN-600	Demonstration, pool, sodium	1470/600	oxide	Russia	1980-
BN-800	Experimental, pool, sodium	2100/864	oxide	Russia	2014-
BREST	Demonstration, loop, lead	700/300	nitride	Russia	(2026?)
FBTR	Experimental, pool, sodium	40/13	carbide (metal)	India	1985-2030
PFBR	Demonstration, pool, sodium	1250/500	oxide (metal)	India	(2023?)
CEFR	Experimental, pool, sodium	65/20	oxide	China	2010-
Joyo	Experimental, loop, sodium	140/-	oxide	Japan	1978-2007, maybe restart 2021
MBIR	Experimental, loop, sodium (Pb-Bi, gas)	100-150 MWt	oxide	Russia	From 2020, under construction
CDFR-600	Demonstration, pool, sodium	600 MWe	oxide	China	From 2023, under const.

Fast Reactors within the Gen IV

Gen IV ideas back in 2004:

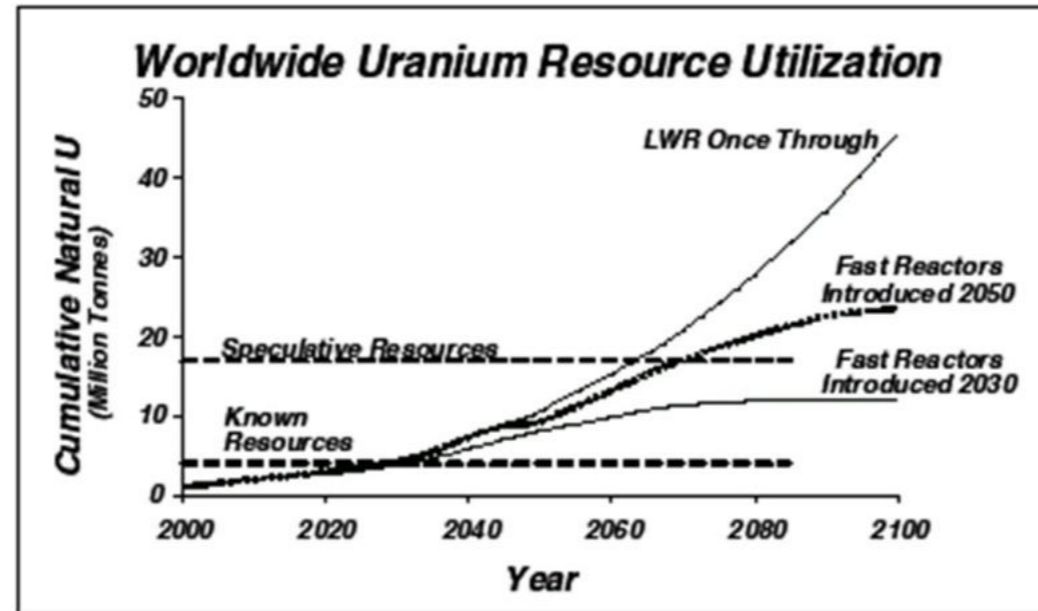

Today we know that these predictions will not come true. There seems to be enough uranium.

At that time, however, the term "breeder" was no longer used, and the word "breeder" became almost forbidden. FBRs became FRs.

Still, the idea of a closed fuel cycle for FRs has not gone away.

Fast reactors within the Gen IV: **SFR, LFR and GFR**. (Theoretically also MSR can be operated in fast spectrum.)

Fuel cycle of FRs – reprocessing of FR spent fuel

Differences from LWR fuel reprocessing:

- **Different cladding material** (stainless steel)
- **In some cases, different fuel** (not only coxide, but also metallic, nitride, carbide)
- **Different fuel composition** (high concentrations of U-235 and/or plutonium)
- **High concentration of fission products and fissile material** which implies high radioactivity, high heat generation and risk of reaching critical mass.

Previously, there was another requirement - that the FBR spent fuel be reprocessed as soon as possible so that the newly breed plutonium could be used immediately to fabricate new fuel. This means that the fuel could be reprocessed after only a short cooling period.

Most of these requirements could not be met by hydrometallurgical reprocessing methods (PUREX). Therefore, since the late 1950s, pyrochemical separation methods were developed which were expected to meet the requirements for reprocessing FR spent fuel.

Experience to date:

Hydrometallurgy (solvent extraction) – modified PUREX technology

- Experimental reprocessing of irradiated fuel from Phenix FR (Atalante laboratories, Marcoule, France),
- Experimental reprocessing of SNF from BN-600 and BOR-60 (Mayak plant, Ozersk, RF),
- Experimental reprocessing of SNF from FBTR (oxide and carbide fuel, CORAL facility in IGCAR Kalpakkam, India).

Pyrochemistry (Molten Salt Electrochemical Separation Processes, Fluoride Volatility Method)

- Experimental processing (electrorefining) of uranium from EBR-II spent fuel (INL, Idaho Falls, USA – electrochemical molten salt technology),
- Semi-industrial reprocessing SNF from BOR-60 (Dimitrovgrad Dry Process with subsequent MOX production by VIBROPACK technology, RIAR, Dimitrovgrad, RF – electrochemical molten salt technology),
- Semi-pilot experimental technology of SNF from Rapsodie FR (Attila facility at CEA, Fontenay-aux-Roses, France – fluoride volatility method),
- Increased laboratory and semi-pilot experimental reprocessing of SNF from BOR-60 (FREGAT and FREGAT-2 lines, RIAR, Dimitrovgrad, USSR in collaboration with Czechoslovakia – fluoride volatility method).

Thermal Oxide Reprocessing Plant - THORP Sellafield, UK



Allegro should be a GFR demonstrator, using MOX or UOX fuel in closed fuel cycle. The system should meet the Gen-IV non proliferation requirements.

UOX: enrichment about 19 % U-235

MOX: natural uranium + about 23 % Pu

Both hydrometallurgical and pyrochemical processes should meet the increased proliferation resistance.

Hydrometallurgical technologies = solvent extraction – PUREX process
LWR, BWR fuel reprocessing

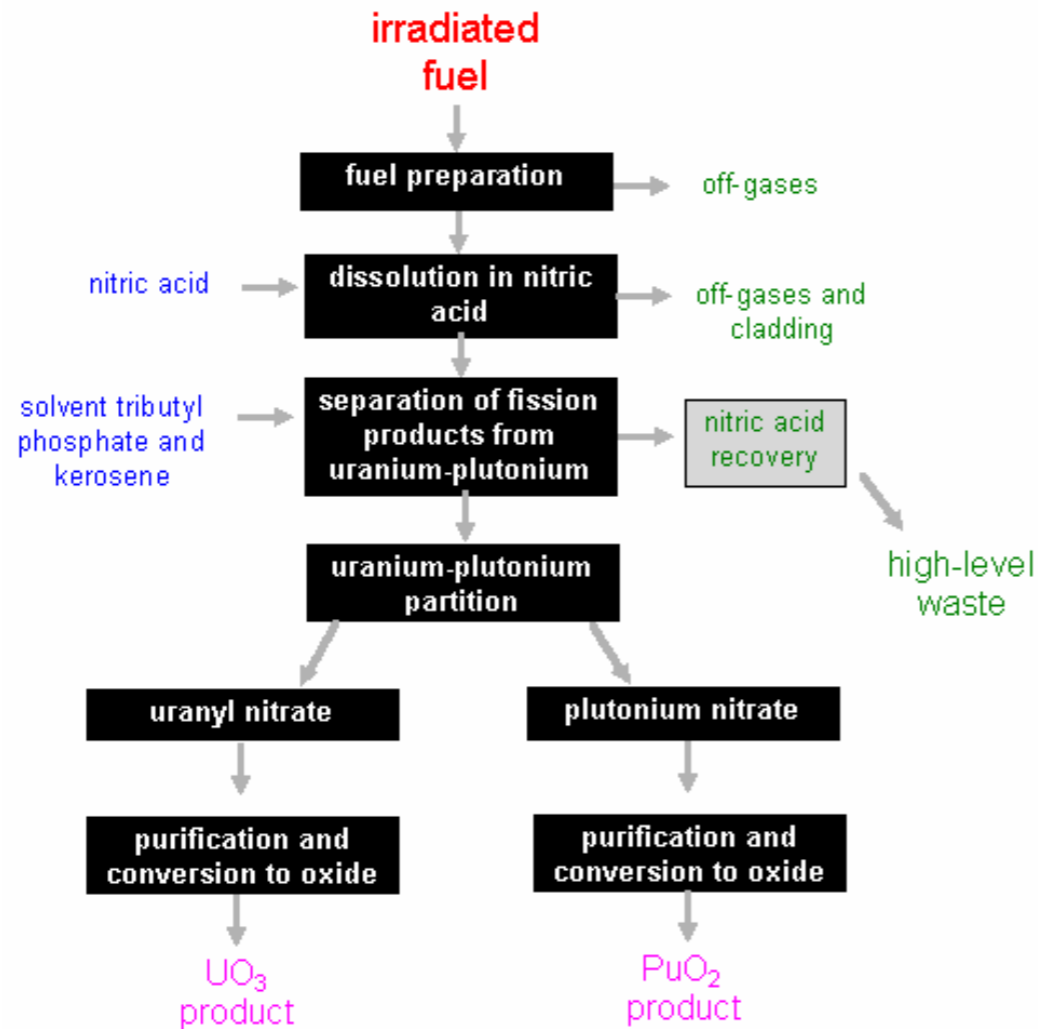

Hydrometallurgical reprocessing (PUREX) with increased proliferation resistance

Modified PUREX in Rokkasho Mura

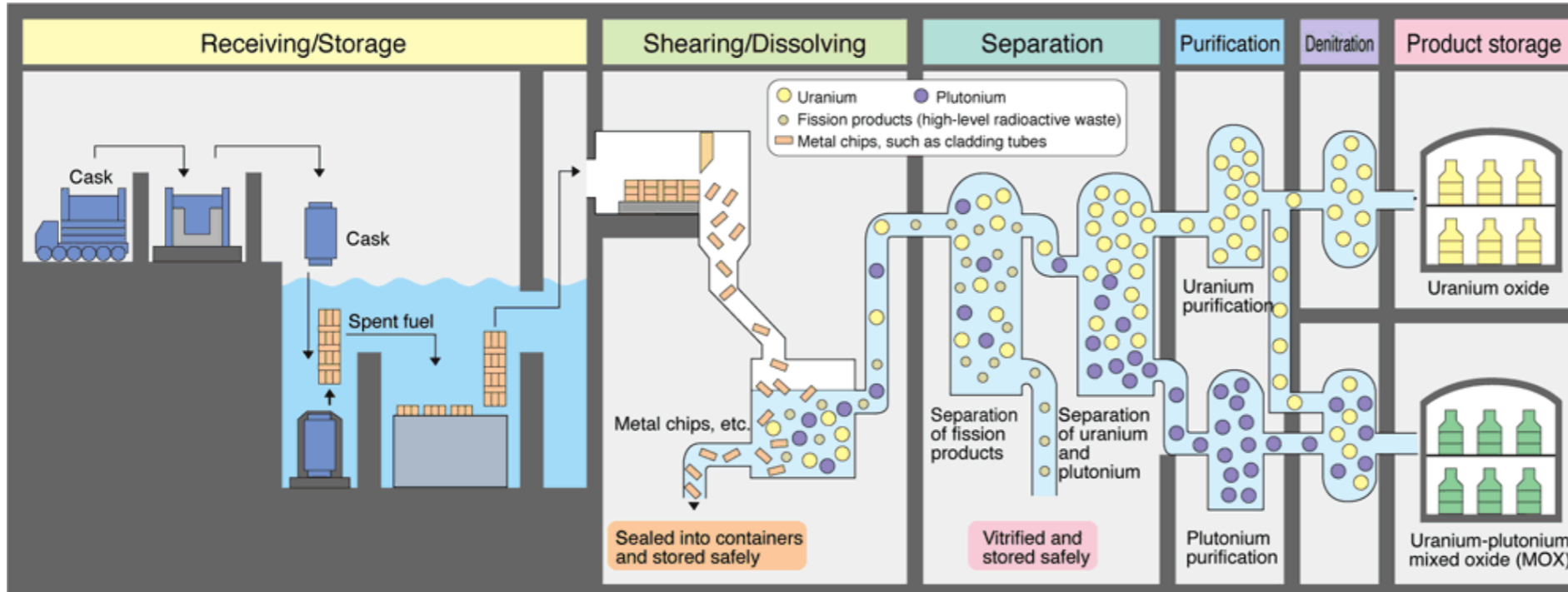

Fluoride Volatility Method was selected from pyrochemical technologies

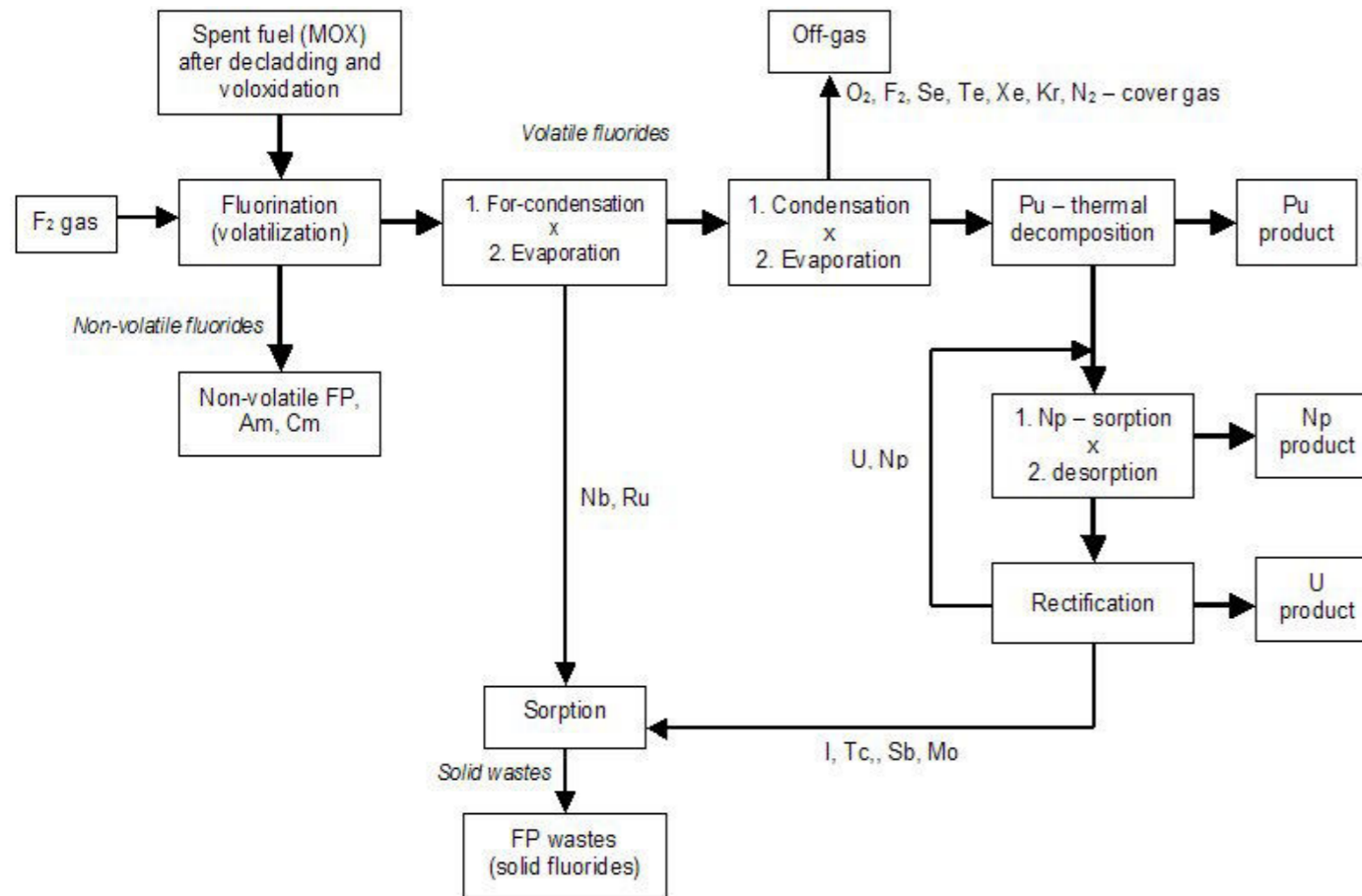

After an assessment of hydrometallurgical and pyrochemical technologies, a technology based on Fluoride Volatility Method was selected.

FVM is pyrochemical reprocessing technology based on partitioning of actinides and fission products on the basis of individual volatility of spent fuel components.

While uranium, neptunium and partially plutonium form volatile hexafluorides by reaction with fluorine gas, most of the fission products and minor actinides (Am, Cm) form solid fluorides.

FVM was originally tailored for oxide fuel FBR reprocessing.

Reprocessing by Fluoride Volatility Method

Fluoride Volatility Method (FVM) is regarded as a promising advanced pyrochemical reprocessing technology, which can be used for reprocessing mainly of oxide spent fuels coming from future Generation IV fast reactors (FR), especially of fast breeders. The technology should be chiefly suitable for the reprocessing of advanced oxide fuel types e.g. fuels with inert matrixes and/or fuels of very high burn-up, high content of plutonium and very short cooling time, which can be hardly reprocessed by hydrometallurgical technologies due to their high radioactivity.

FVM technology has been proposed primarily for reprocessing Fast Breeder Reactor fuel in order to overcome the main shortcomings of hydrometallurgical separation methods - i.e. the problems associated with the use of a moderating agent, the limitations of reprocessing material with high plutonium concentrations and, in particular, the susceptibility of organic extractants to radiolytic damage and hence the need for long cooling of spent fuel prior to reprocessing.

- **Proliferation Resistance and Physical Protection (PRPP)** aspects describe the degree of protection of a given technology or entire reactor system against the possible diversion of fissile nuclear or radioactive material by a state or organization, as well as the degree of internal engineering and physical protective barriers against possible terrorist or robbery theft of these materials.
- While the "Proliferation Resistance" aspects are more focused on assessing the potential risk of misuse of the technology or the entire nuclear system by the state or possibly the organization operating the technology, the "Physical Protection" aspects are primarily concerned with assessing the physical and engineering barriers that prevent the theft of the material by terrorist organizations or criminal activity.

Some of PRPP criteria

- Proliferation Technical Difficulty
- Proliferation Resources
- Proliferation Time
- Detection time (Safeguardability)

- Operational Accessibility
- Adversary Delay
- Detection Time
- Physical Protection Resources

Reprocessing by Fluoride Volatility Method

Method how to increase proliferation resistance

Original proposal of FVM

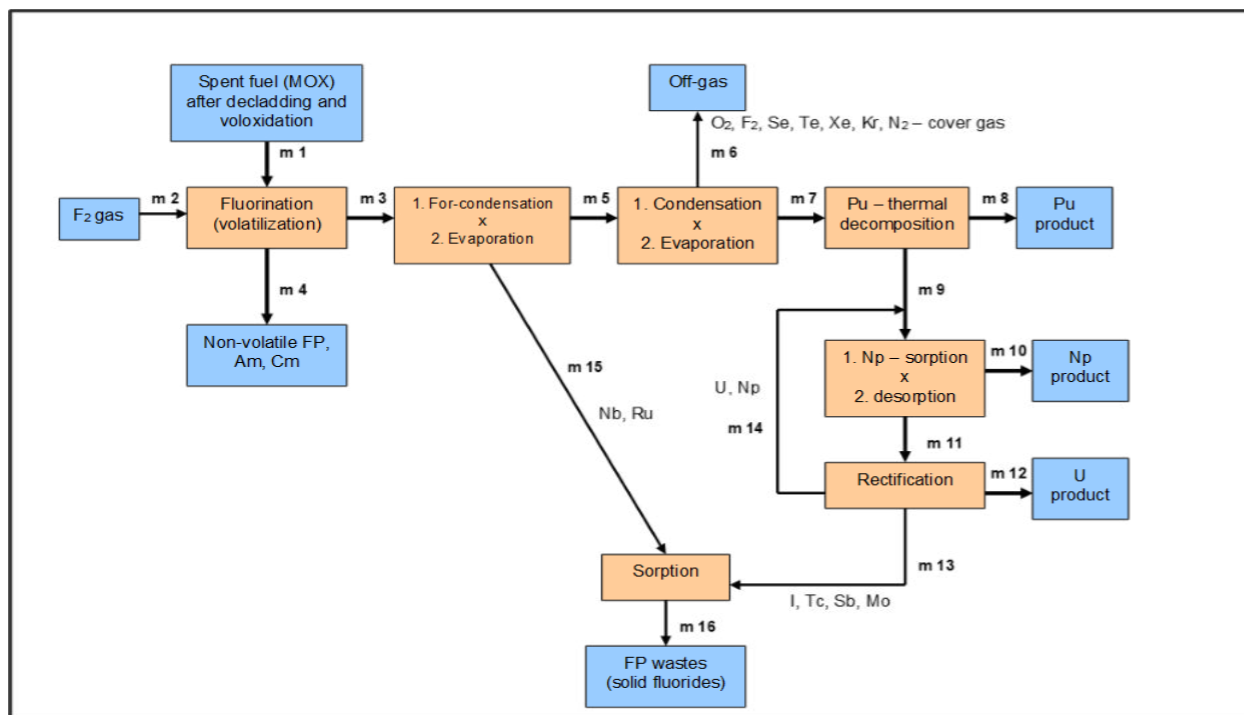

SafeG proposal

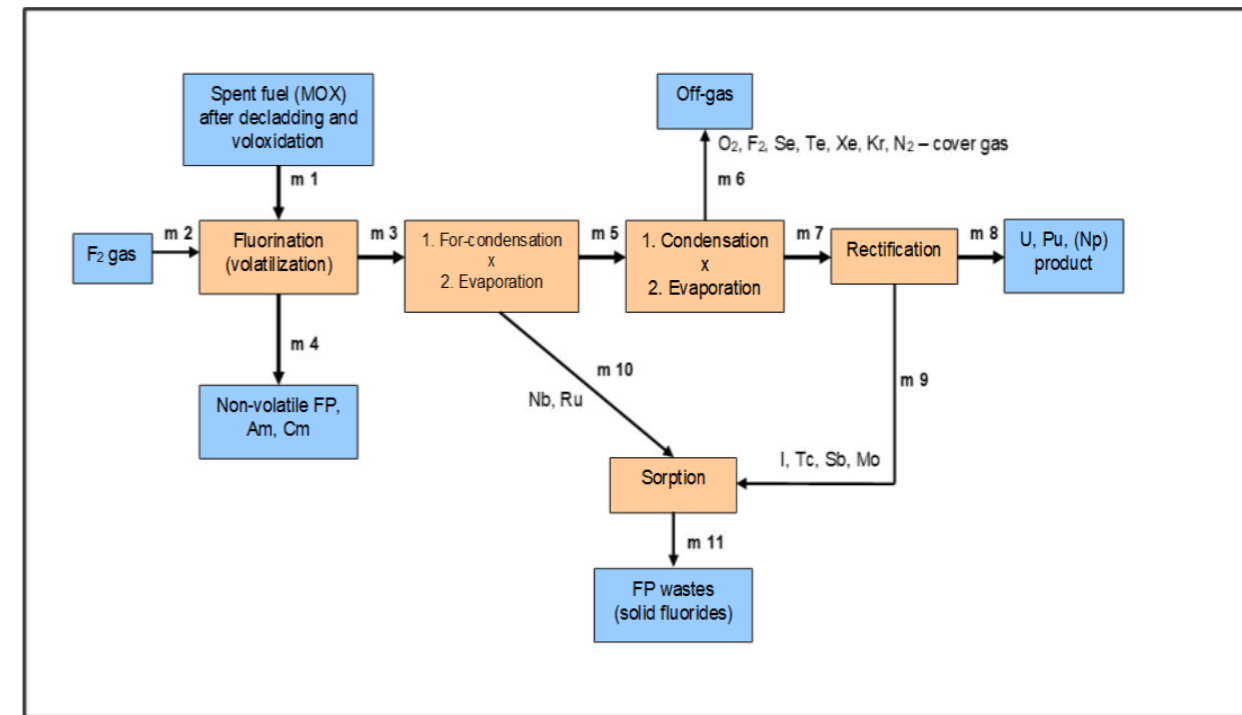

Table 9: Composition rates of actinides in fresh MOX fuel and output products stream from reprocessing by FVM after 1 year cooling time

Isotope	Initial MOX fuel composition rate of actinides	FVM product composition rate of actinides
U234	0,00E+00	5,51E-05
U235	5,23E-03	4,97E-03
U236	0,00E+00	1,19E-04
U238	7,31E-01	7,49E-01
Np237	0,00E+00	3,02E-05
Pu238	7,13E-03	7,17E-03
Pu239	1,48E-01	1,38E-01
Pu240	6,84E-02	6,62E-02
Pu241	1,95E-02	1,59E-02
Pu242	1,93E-02	1,86E-02
Am241	1,85E-03	0,00E+00
total	1,00E+00	1,00E+00

- The above table shows that for the SafeG GFR, the composition (and the relative ratios of U and Pu) of the output U-Pu product using FVM reprocessing is very similar to that of the MOX feed fuel for this reactor. Thus, it can be concluded that in a MOX fuel cycle the GFR reactor would be very close to the nature of an iso-breeder.
- From an overall assessment of the characteristics of the FVM technology, it is clear that this technology has significant proliferation resistance and physical protection and, if used for reprocessing FGR fuel, would meet the current PRPP criteria as recommended and required by the Generation IV International Forum and the IAEA.

PRPP and fuel burn-up

- The fuel burn-up generally affects the composition of the plutonium produced. At low burn-up, there is not enough time for nuclear reactions to take place to produce higher isotopes of plutonium. For military purposes (making a plutonium bomb), practically only the plutonium isotope Pu-239, which is produced by nuclear reactions $^{238}\text{U}(n, \gamma) \rightarrow ^{239}\text{U}(\beta^-) \rightarrow ^{239}\text{Np}(\beta^-) \rightarrow ^{239}\text{Pu}$, is usable. Theoretically, Pu-241 can also be used for military purposes.
- However, in a nuclear reactor, in addition to Pu-239 and Pu-241, plutonium isotopes Pu-240, Pu-242 and Pu-238 are gradually produced. Of these, Pu-240 in particular makes the construction of a nuclear weapon virtually impossible as it is a strong source of neutrons produced by its spontaneous fission. It is not feasible to separate Pu-240 from Pu-239. Moreover, the isotopes Pu-238 and Pu-241 are significant sources of radiation and heat.
- For these reasons, in reactors designed for military purposes, the fuel (uranium) is allowed to burn up very little, so that the plutonium product is practically only Pu-239. Hence “weapons-grade” plutonium is made in special production reactors by burning natural uranium fuel to the extent of only about 100 MWd/t (effectively three months), instead of the 45 000 MWd/t typical of LWR power reactors.

The IAEA categorizes plutonium as follows:

- 1. Weapons-grade plutonium = Pu-239 with less than 8 % Pu-240,
- 2. Reactor-grade plutonium = less than 70 % Pu-239 and more than 19 % Pu-240.

(However, from a military point of view, plutonium containing more than 97 % of Pu-239 and only 1-3 % Pu-240 is considered suitable for the production of a Pu weapon. Such “weapons-grade” Pu is often referred to as “Super-grade“.)

Allegro MOX:

Isotope	Pu-vectors in different burn-up (in MWd/kgHM)									
	0	0,1	0,5	1	10	40	60	100	140	180
Pu 238	0,027	0,027	0,027	0,027	0,027	0,025	0,025	0,025	0,025	0,026
Pu 239	0,564	0,564	0,564	0,564	0,562	0,556	0,551	0,540	0,529	0,519
Pu 240	0,261	0,261	0,261	0,261	0,266	0,280	0,288	0,303	0,316	0,327
Pu 241	0,075	0,074	0,074	0,074	0,071	0,062	0,057	0,050	0,046	0,045
Pu 242	0,074	0,074	0,074	0,074	0,075	0,077	0,079	0,081	0,083	0,083

- Spent fuel reprocessing technology is the most important and sensitive issue from a proliferation resistance viewpoint.
- The reprocessing technologies (both hydrometallurgical and pyrochemical) can be modified to increase the proliferation resistance and physical protection barriers.

The Allegro reactor and its fuel cycle:

- If we apply the PRPP criteria to the fuel cycle of the Allegro reactor, then for MOX fuel, which should be a reference fuel for Allegro, we find that there is no way this fuel can have the characteristics of "weapons-grade" plutonium. The fuel does not meet these parameters in any burnup. The Pu-240 concentrations are always higher than 26 %.

Thank you for your attention.

Specifics in thermal-hydraulic design of GFRs

Jan Pokorny, UJV Rez

SafeG Summer School, Rez, Czech Republic, August 29- September 1, 2022



This project has received funding from the Euratom H2020 programme NFRP-2019-2020-06 under grant agreement No 945041.

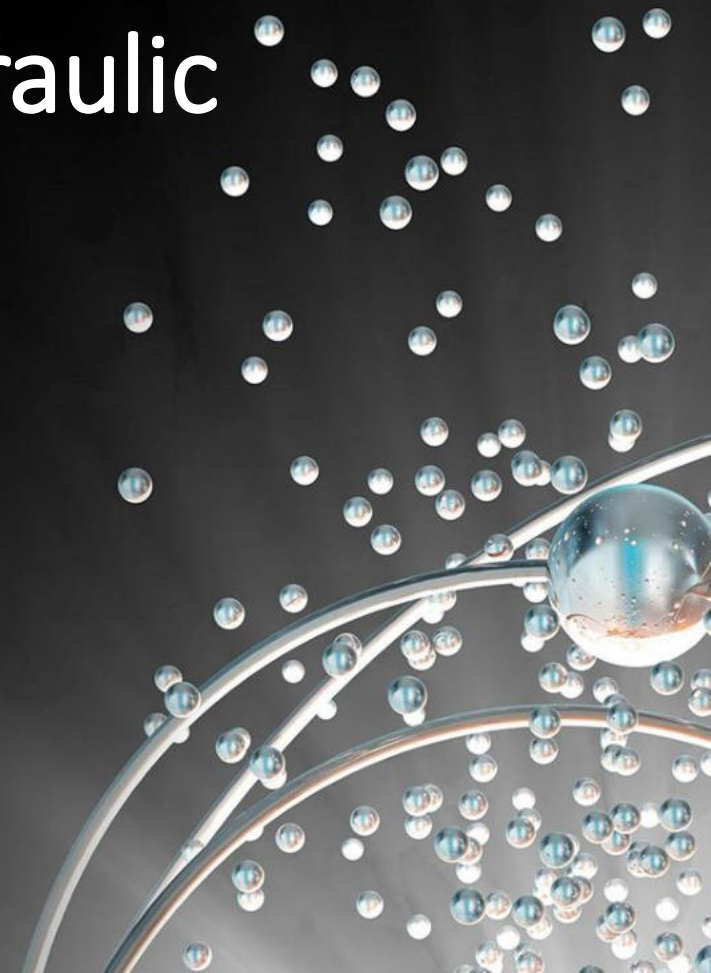

Outline

- Gas cooled reactors – overview
- Gas coolants
- Allegro overview
- Allegro DHR system development

Gas cooled reactors - history

- Rich history
 - 1947 Windscale Piles, UK (atmospheric, air cooled, open cycle)
 - 1953 Magnox reactors, UK (pressurized CO₂, closed cycle)
 - 1960s Advanced gas cooled reactors ARGs (CO₂, output 650°C)
- Helium high temperature reactors (HTRs)
 - Dragon (UK) 1976, AVR and THTR-300 (Germany) 1989, Peach Bottom 1974 and Fort St Vrain (US), HTR-10 & HTR-PM (China), HTTR (Japan)
 - Outlet temperatures of 750 to 950 °C
- Fast reactors (no moderator, rich fissile material, compact core, fast neutrons)
 - Water is not an option, since it acts as a moderator -> lead, sodium, gases as coolant

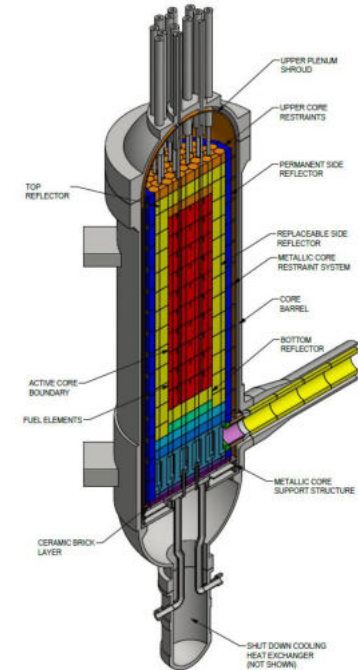
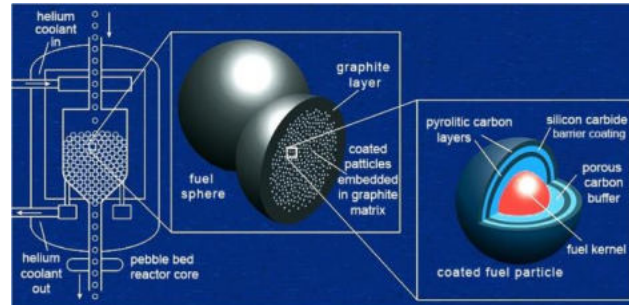

Gas coolants

- Advantages
 - No phase change
 - Low reactivity insertion due to voiding of the coolant
 - Optically transparent and electrically non-conducting
- Disadvantages
 - Low density (pressurization, severity of LOCA)
 - Water/Steam ingress can induce significant positive reactivity (chemical attacks)
 - No liquid pool forming to cool debris in case of a severe accident
 - LOCA pressurizes the containment more significantly
 - Low thermal inertia can be dangerous in fast reactors when forced circulation or high pressure is lost
 - Compact cores make conduction cool-down insufficient to remove decay heat -> dedicated decay heat system + injection of heavy gas
 - He specifically needs heavier gas injection for natural convection due to low density

Carbon dioxide vs. Helium

- Molecular weights: 44 kg/kmol CO₂ vs 4 kg/kmol He
 - CO₂ - less pumping power and lower pressure
- Cp,CO₂ = 1.15 kJ/kg/K and Cp,He = 5.195 kJ/kg/K
 - CO₂ - less pumping power and lower pressure
 - He – superior thermal conductivity
- CO₂ dissociates into CO+O₂ by radiolytic dissociation at ~600°C while He is inert, but needs purification systems
- In He environment, diffusion bonding of valves can be a problem

	Water	CO2	He	Ar	Na
	150 bar, 300°C	60 bar, 500°C	60 bar, 500°C	60 bar, 500°C	1 bar, 500°C
ρ kg/m³	725,53	40,86	3,7	37,29	857
Cp J/kg/K	5476	1182	5190	525	1262
λ w/m/K	0,56	0,06	0,303	0,037	66,3
μ 10⁻⁵ Pa.s	8,83	3,33	3,73	4,54	24.3
HTC (normalized to water)	1	0.7	0.99	0.65	21.

ALLEGRO – design overview

- Two consecutive core configurations
- Driver core – MOX/UO₂ pin-type fuel in steel cladding, experimental positions for fuel qualification
- Refractory core – (U,Pu)C or MOX pin-type fuel in SiC-SiCf cladding <- GFR reference fuel
- Target core outlet temperature 850°C
- Power density up to 50 - 100 MW/m³
- Focus on fully passive safety to meet GENIV objectives

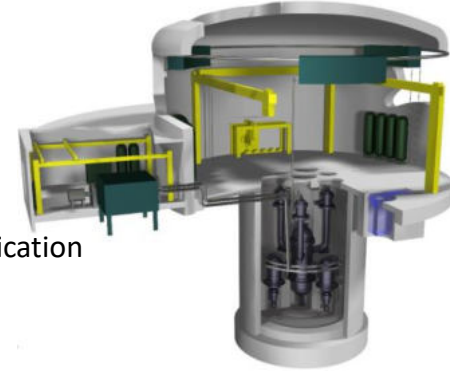

ALLEGRO main characteristics	
Nominal Power (thermal)	75 MW
Driver core fuel/cladding	MOX(UO ₂) / 15-15Ti Steel
Experimental fuel/cladding	UPuC / Sic-Sicf
Fuel enrichment	35% (MOX) / 19.5% (UO ₂)
Power density	50 - 100 MWth/m ³
Primary coolant	He
Primary pressure	7 MPa
Driver core in/out temperature	260°C / 530°C
Experimental fuel in/out T	400°C / 850°C

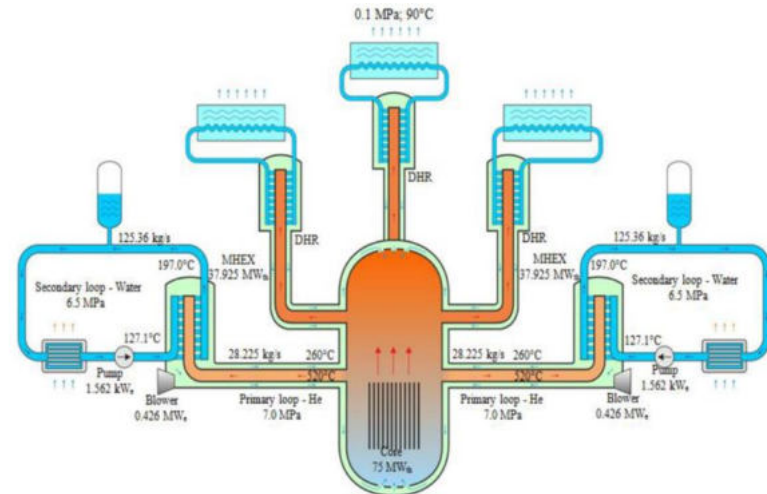

ALLEGRO Safety Concept

- Three key safety systems
 - Guard Vessel



DHR system

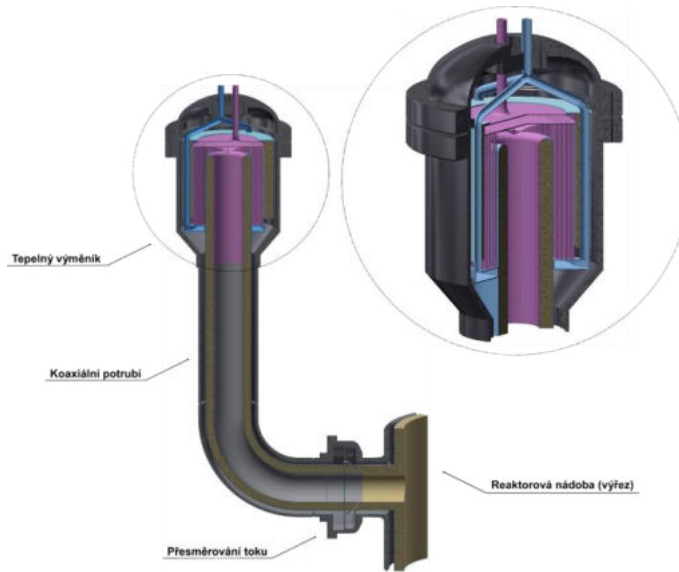

Emergency coolant injection

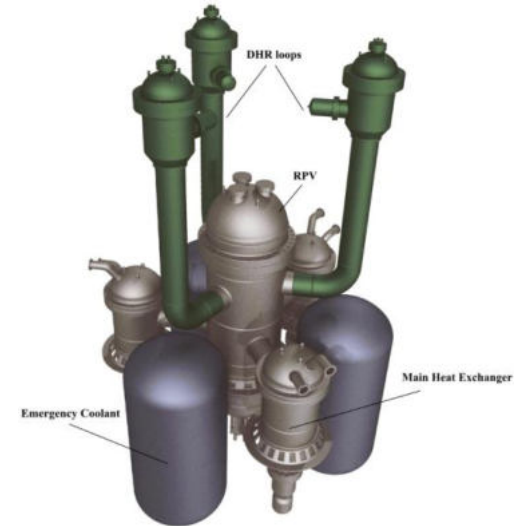

Accident cooling strategies in other He cooled reactors

- HTR – PMR (RCCS)
 - Core cooling exclusively through radiation heat transfer to the core cavity
 - Possible due to large thermal inertia of the core (huge amount of graphite)
 - Completely different from GFR – however, shows that radiation heat transfer in high-temperature reactors plays an important role

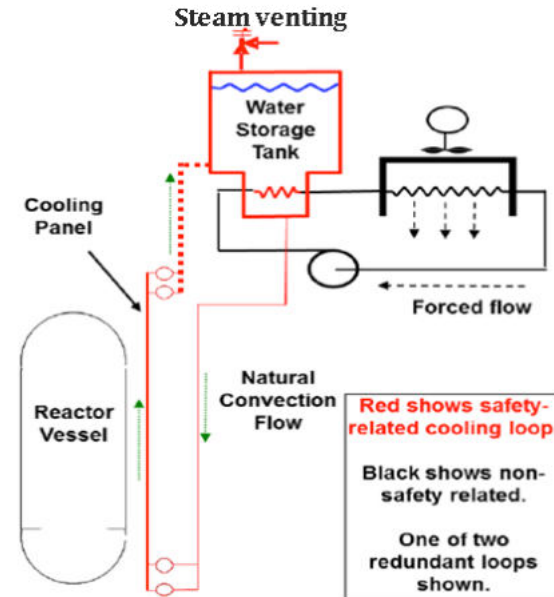

ALLEGRO DHR first designs

- CEA 2009 preliminary design finished in 2016 during GoFastR European project
- Preliminary design even considered DHR for shutdown
- The design requirements were very simple
- Dissipation of decay heat for every loop (2 MW)
- Redundance (3 loops)
- Safety (ability to isolate the loop)
- Function with isolated main primary loops (consisting blowers)

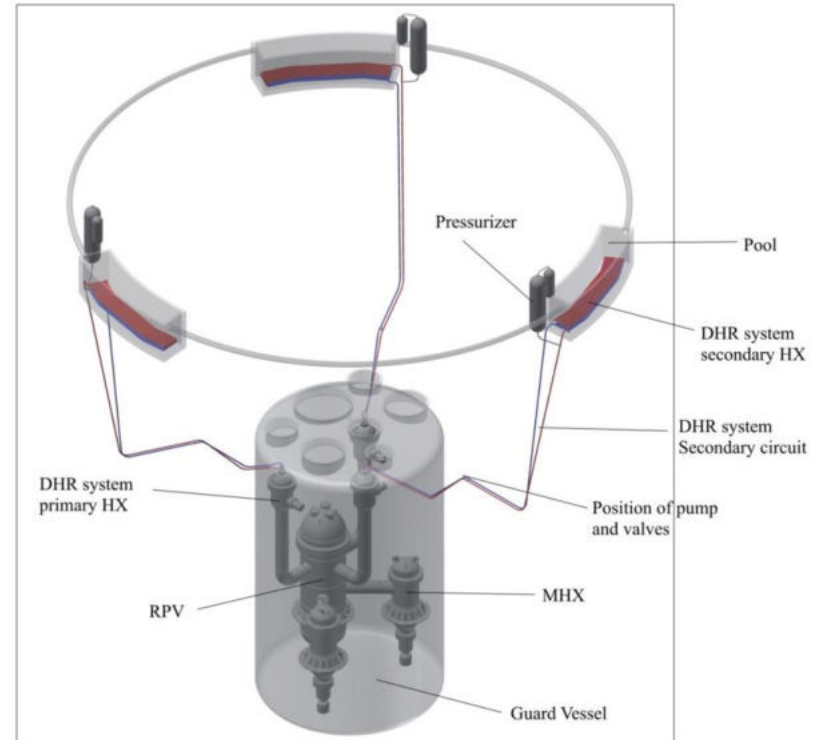

ALLEGRO DHR first designs

- Parameters of the first (2009-2016 design)
 - U-tube heat exchanger designed for 2,6 MW
 - Check-valves and pumps on the DHR secondary circuit
 - Radial blower on the primary side with possible bypass
 - Secondary pool heat exchanger with U-tubes
 - Considered for both forced AND natural convection

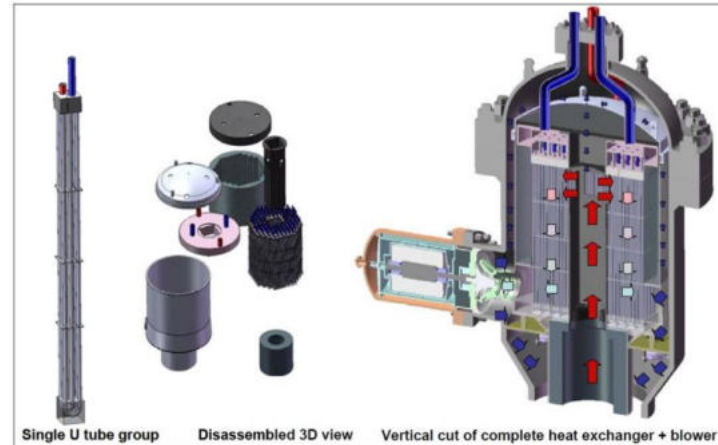
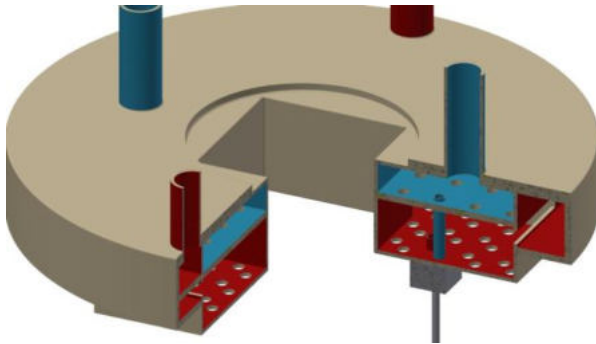

ALLEGRO DHR first designs

- Design issues
 - Inability to isolate the cross duct - water ingress
 - Water in secondary circuit above the fuel level
 - DHR system preconditioning for smooth flow establishment
 - For mode in natural convection possibly problematic:
 - Local overheating of U-tubes if flow is disrupted
 - The passive valve design was largely unverified for every reactor state, possible problems with accidental opening > bypass
 - No preconditioning
- Poor compactness, very complicated, challenging to manufacture

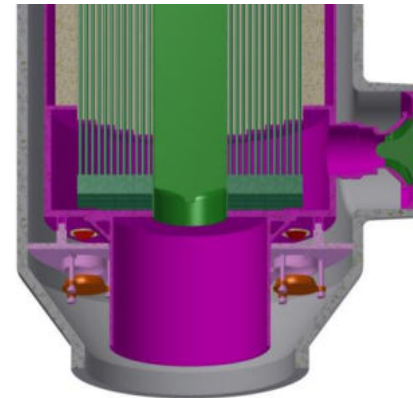
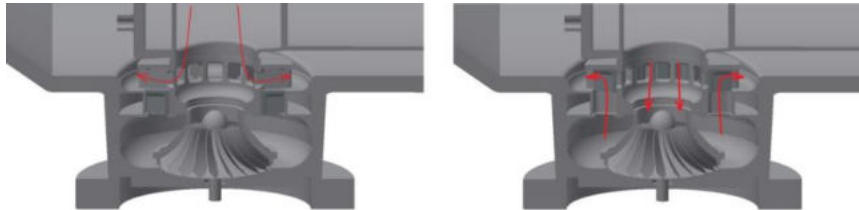

ALLEGRO DHR development

- New design criteria:
 - Full passivity
 - Removal of primary blower
 - Removal of the secondary water pump – straight HX tubes for minimal flow resistance
- Increased reliability
 - Design a preconditioning system
 - Reduce number of moving and heavily loaded parts (revision of valves and HX)



Natural convection

- Natural circulation in enclosed systems depends on:
 - Elevation difference between heat source and heat sink
 - Density difference between hot and cold medium
 - Proper geometry of the circuit

$$\Delta p_{driving} = (\rho_{cold} - \rho_{hot}) \cdot h \cdot g$$

- Equation suggests the driving force being linear function of elevation difference
- With decreased driving force the temp. of the hot medium will rise, if we keep the temp. of cold medium constant rising difference in densities somewhat offsets lower elevation

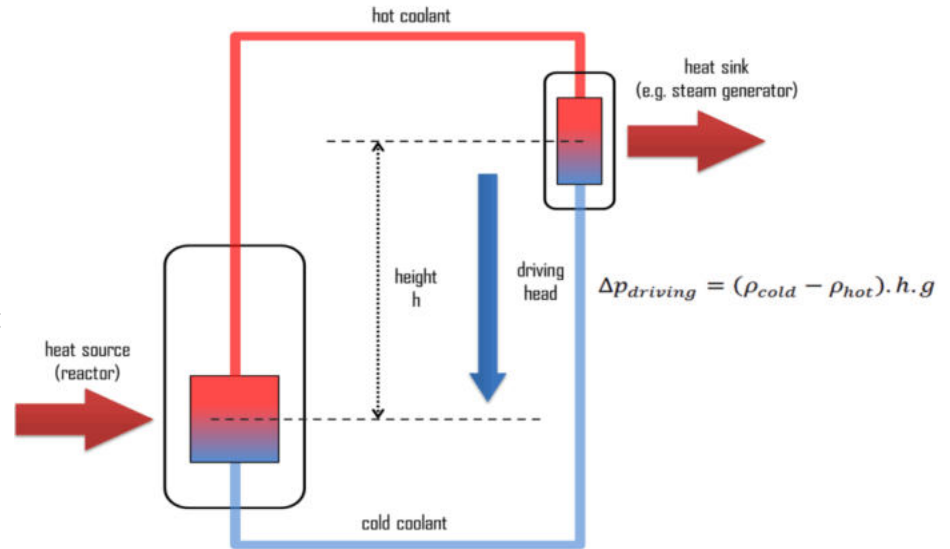

Natural convection – sensitivity study (1)

- Simplified model with detailed core and 1 DHR loop
- Boundary conditions
- Secondary side constant 1 MPa, 160°C
- Nominal ALLEGRO decay heat
- Zero initial velocity
- 8 different elevations of the DHR system for 1 MPa or 7 MPa (5,7,10,13,15,17,20,30 meters)

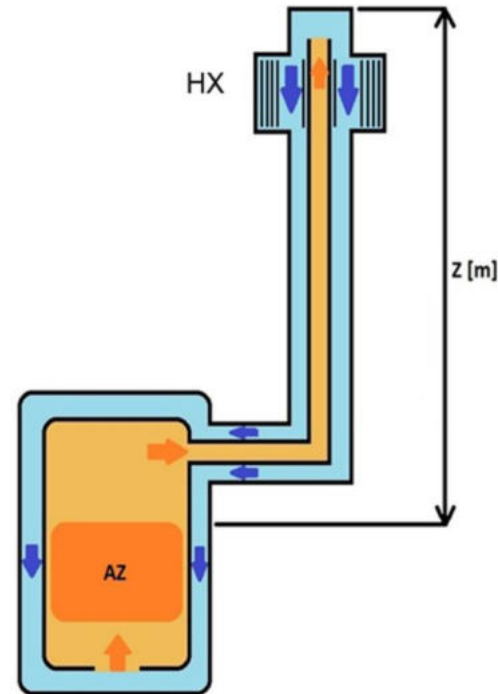

Natural convection – sensitivity study (2)

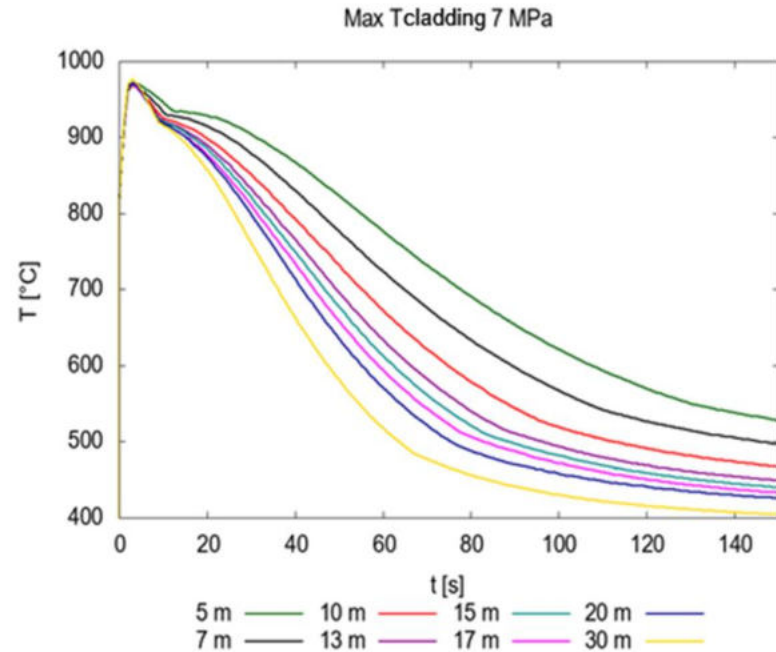
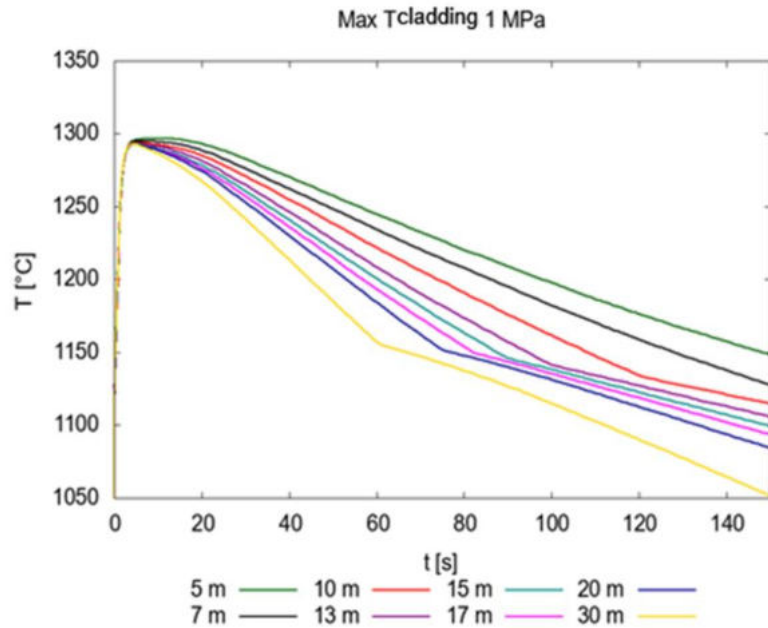

Natural convection – sensitivity study (3)

- Full MELCOR ALLEGRO model
- SBO/LOCA 75mm + SBO with 3x200m³ N₂ accumulators available
- 1/3 DHR loops with elevations of 10,15 and 20 m
- 72/18/0 DHR blower pressure drop coefficient
- 36 cases in total
- Case B1 – 3 loops, ξ blower = 72

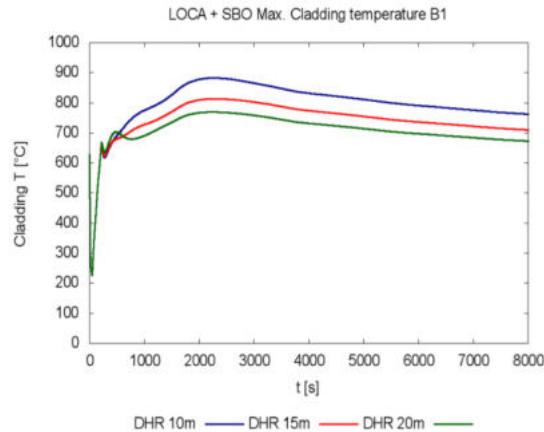

- Results
 - Proven hypothesis
 - $h > 10\text{m}$ advised
 - Necessity of preconditioning
 - Necessity of getting rid of the blower

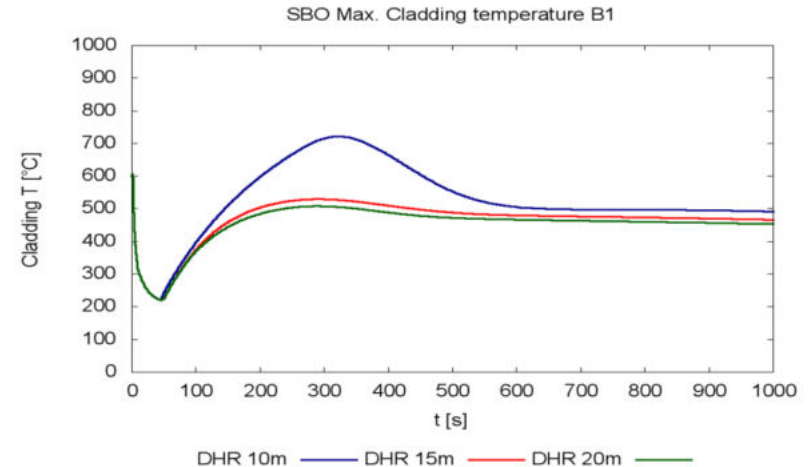

Decay heat removal system – innovative version

- **Dedicated system:**
 - Fully passive, based on natural convection
 - Continuously pre-conditioned during normal reactor operation with a small controlled primary coolant flow
 - Key safety systems in LOFA
 - 2 x 100 % loops
 - Patented in the Czech Republic, international patent pending

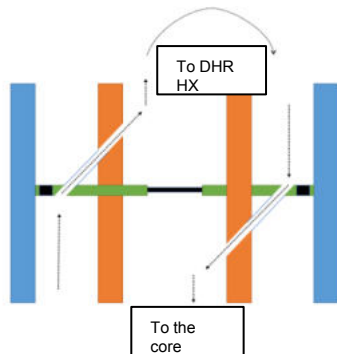

System in the pre-conditioning settings

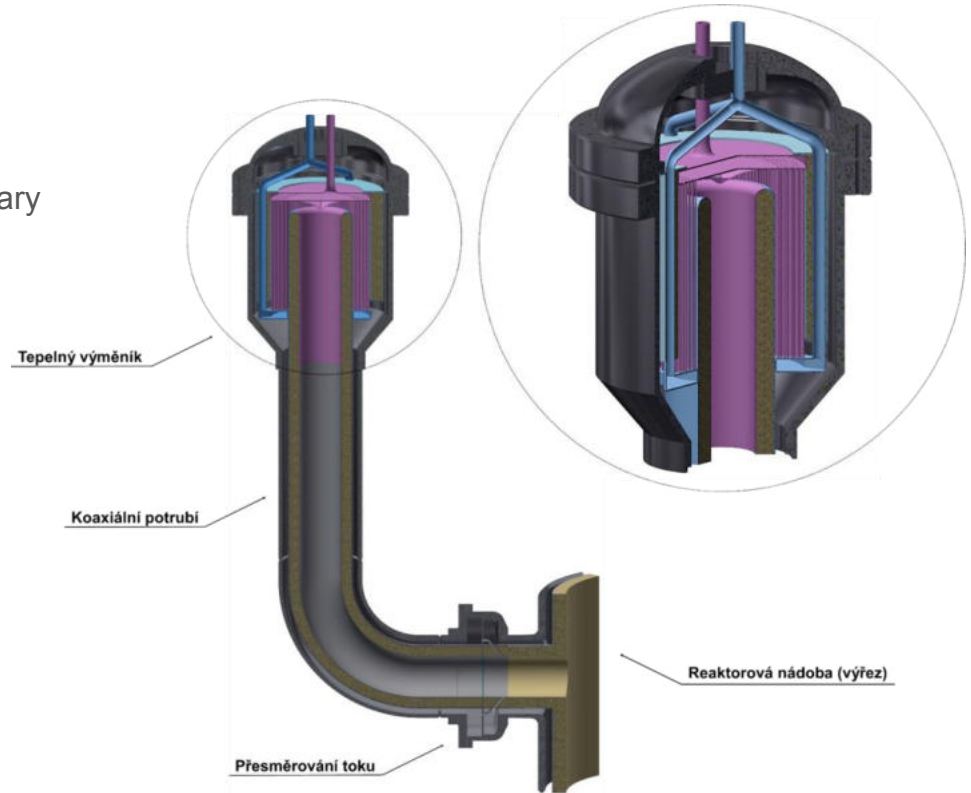

ALLEGRO DHR Preconditioning device

- Main features
 - Located near the connection of the DHR duct to the RPV
 - Set of interconnected valves controlled by pressure difference between the cold and hot leg of the main ducts
 - Three possible modes:
 - Pre-conditioning (1-2 % of nominal flow)
 - Fully open (DHR system actuation)
 - Fully closed (DHR loop isolated)

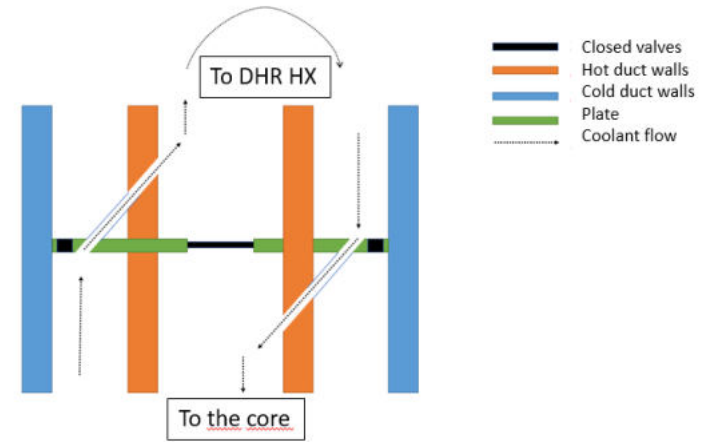

ALLEGRO DHR Preconditioning device – actual design

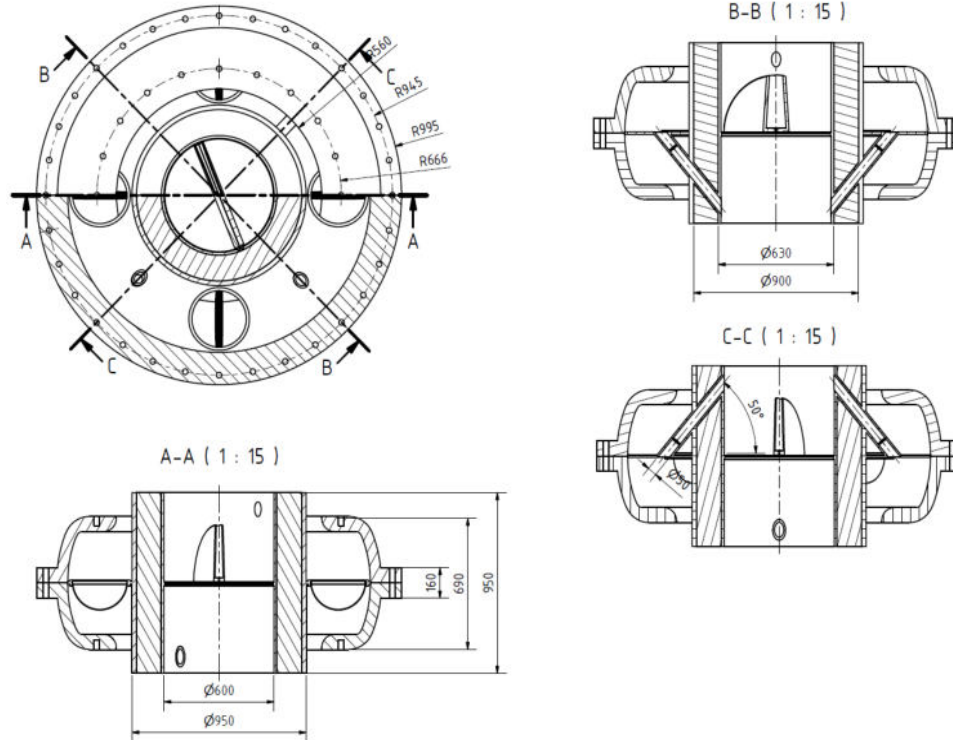

Proof of concept analysis with MELCOR – SBO driver core

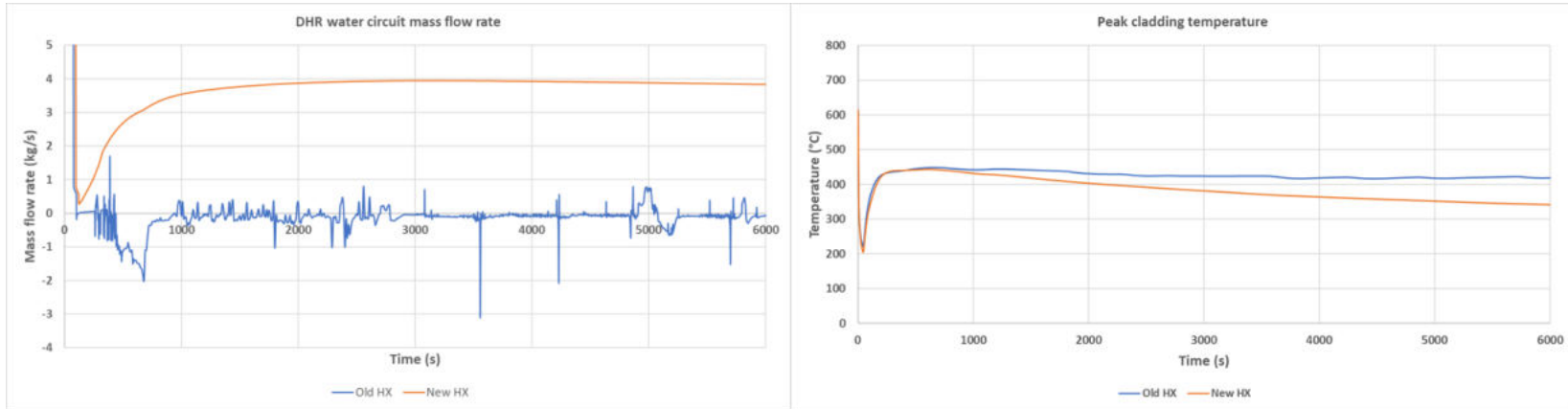

Proof of concept analysis with MELCOR–LOCA+SBO driver core

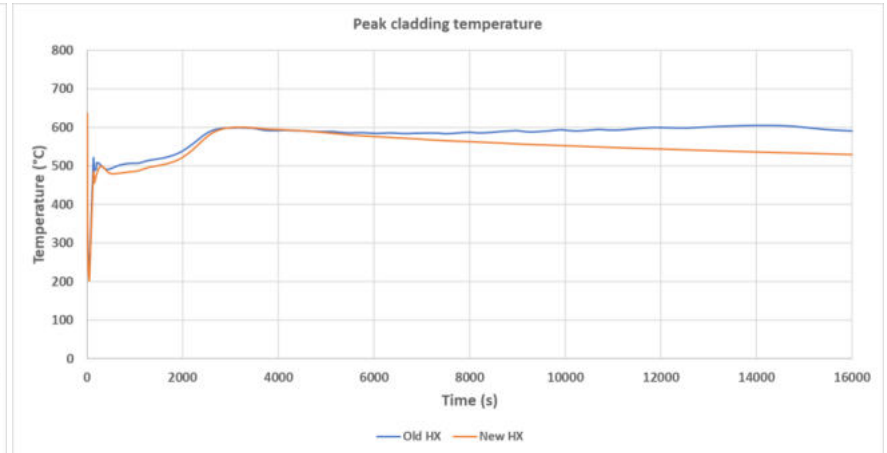
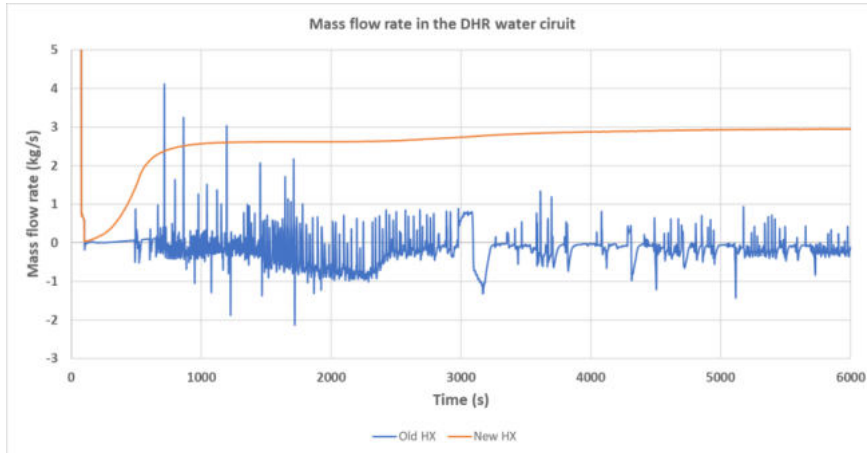

Future development on the ALLEGRO safety

- Valve testing
- Decision concerning number of loops and their passivity (2, 3 passive, 2+1?)
- Manufacturing of parts and physical tests in S-Allegro

Thank you for your attention!



References

- E. Bubelis – Seminar "Coolants for fast neutron reactors", Paris, 2013.02.20.
- Kabach, O., Chetaine, A., Benchrif, A., Amsil, H., & El Banni, F. (2021). *A comparative analysis of the neutronic performance of thorium mixed with uranium or plutonium in a high-temperature pebble-bed reactor. International Journal of Energy Research, 45(11), 16824–16841.* doi:10.1002/er.6935
- D. Hittner, GEMINI+, Task 2.2: the Reactor Cavity Cooling System (RCCS), 6.11.2018

GFR Thermal-hydraulics

Gusztáv Mayer, EK, gusztav.mayer@ek-cer.hu
GFR Summer Scool, Prague, 30 August 2022

SafeG⁴

SAFETY OF GFR THROUGH INNOVATIVE MATERIALS,
TECHNOLOGIES AND PROCESSES



This project has received funding from the Euratom H2020 programme
NFRP-2019-2020-06 under grant agreement No 945041.



ALLEGRO without cooling (following a srcam) SafeG[®]

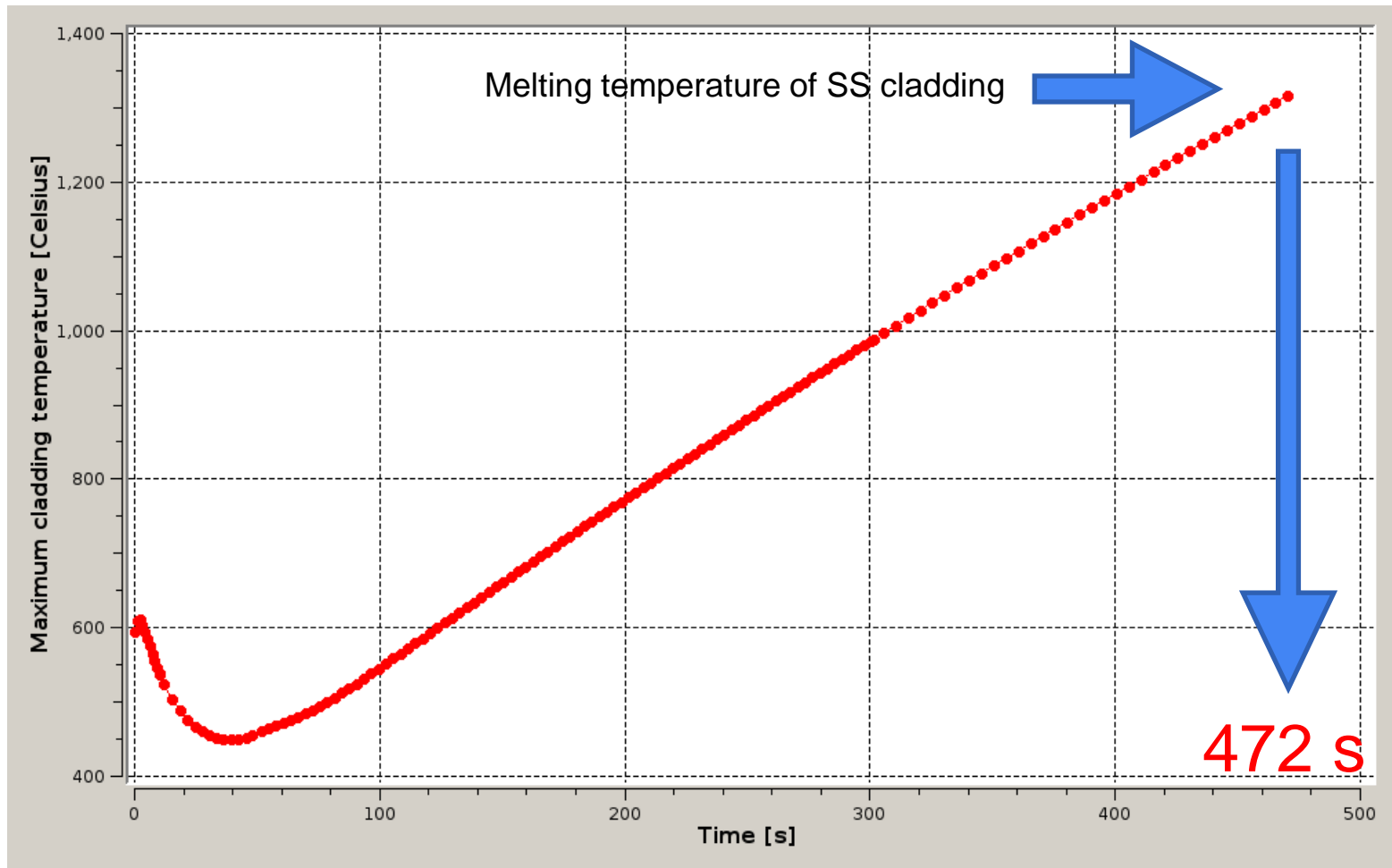

What are the reasons?

1. High power density – 100MW/m³
2. And...

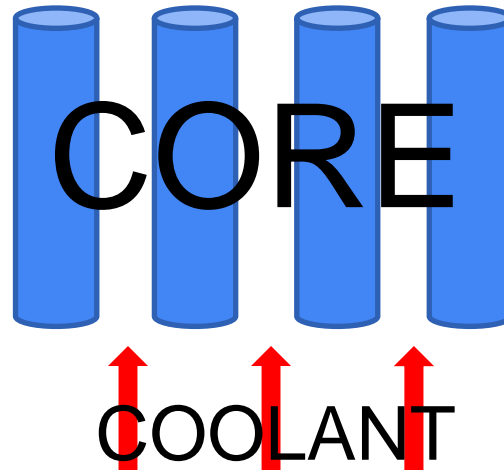

Comparison of coolants

	Helium	Water	Nitrogen	Sodium	Lead
Specific heat c_p [kJ/kgK]	5,1932	4,7-5,5	1,040	1,26	0,13
Density [kg/m ³]	4-6,5 (ALLEGRO)	720-780 (VVER- 440)	70 (ALLEGRO)	968	11340
$c_p * \rho$ [kJ/(m ³ K)]	25	3750	70	1200	1470
Specific latent heat of vaporization [kJ/kg]	-	2 256,37	-	113	871

Despite this drawback why are we developing GFRs?

Advantages:

- Closure of fuel cycle (fast reactor)

- Faster neutron spectrum, higher conversion ratio

- High core outlet temperature (~800C)

 - Good thermal efficiency

 - Brighton cycle + Rankine cycle

 - Hydrogen production

- Transparent coolant

- No phase change, no critical heat flux

ALLEGRO

The background of the slide is dark teal with a pattern of lighter teal circles of varying sizes, scattered across the lower half of the page.

Selection from more than 100 reactor types

→ 6

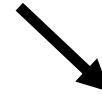
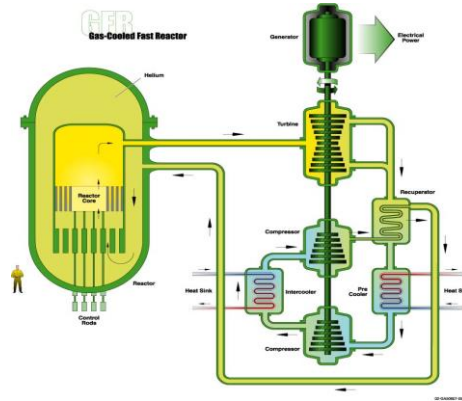
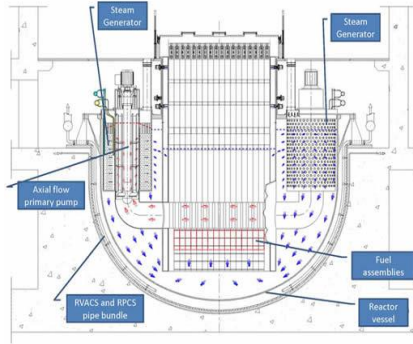
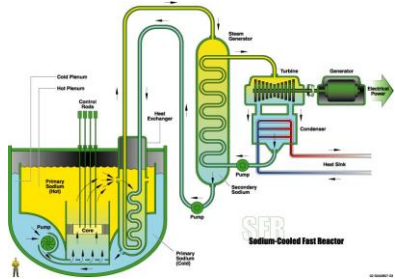

ALLEGRO
75 MWth

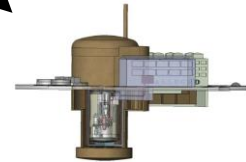

GFR
2400 MWth

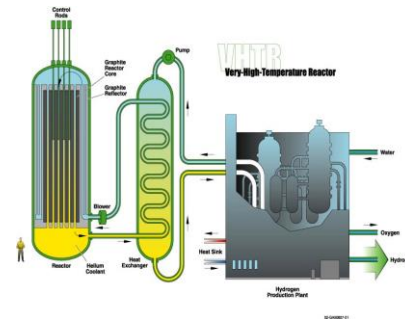
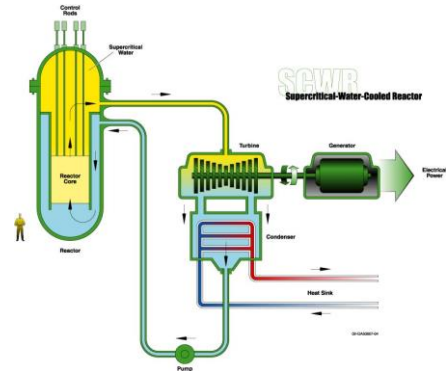
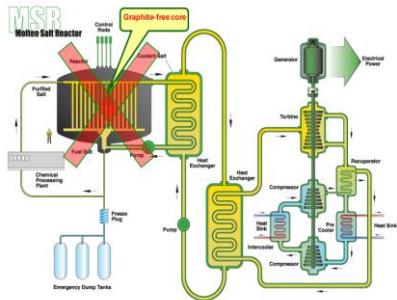
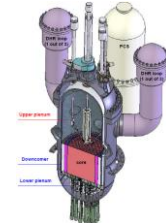

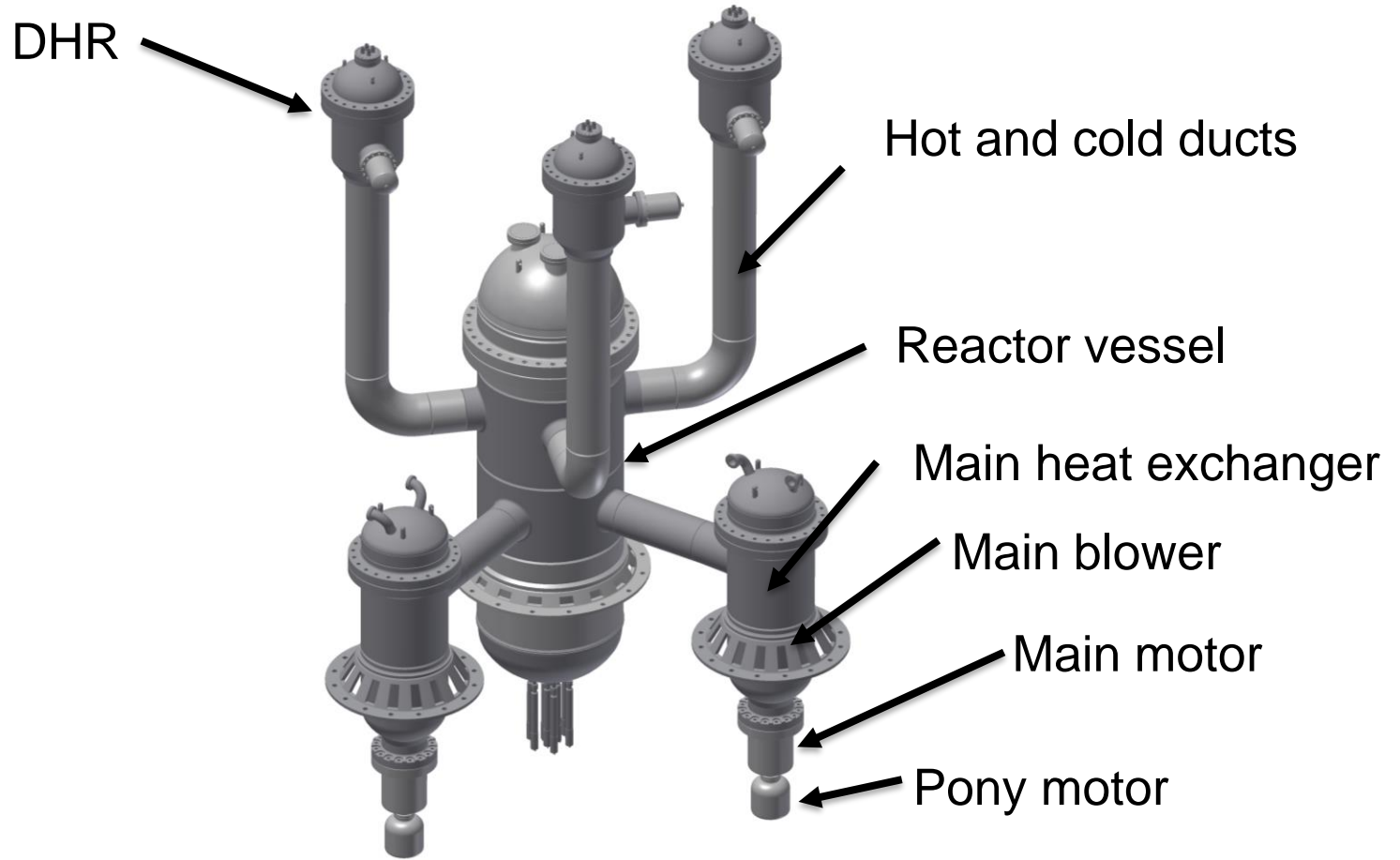

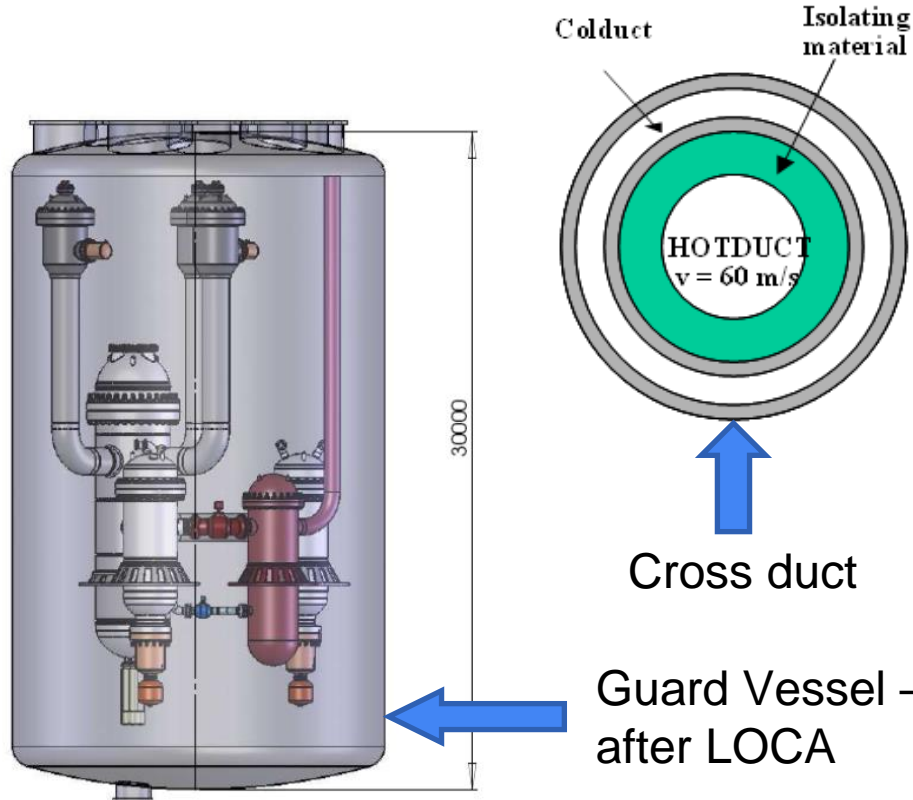

75 MWth (currently)
Pin type core
Helium coolant
Heat is removed by an aircooler
No electricity generation

Guard Vessel – GV – to decrease the pumping power after LOCA

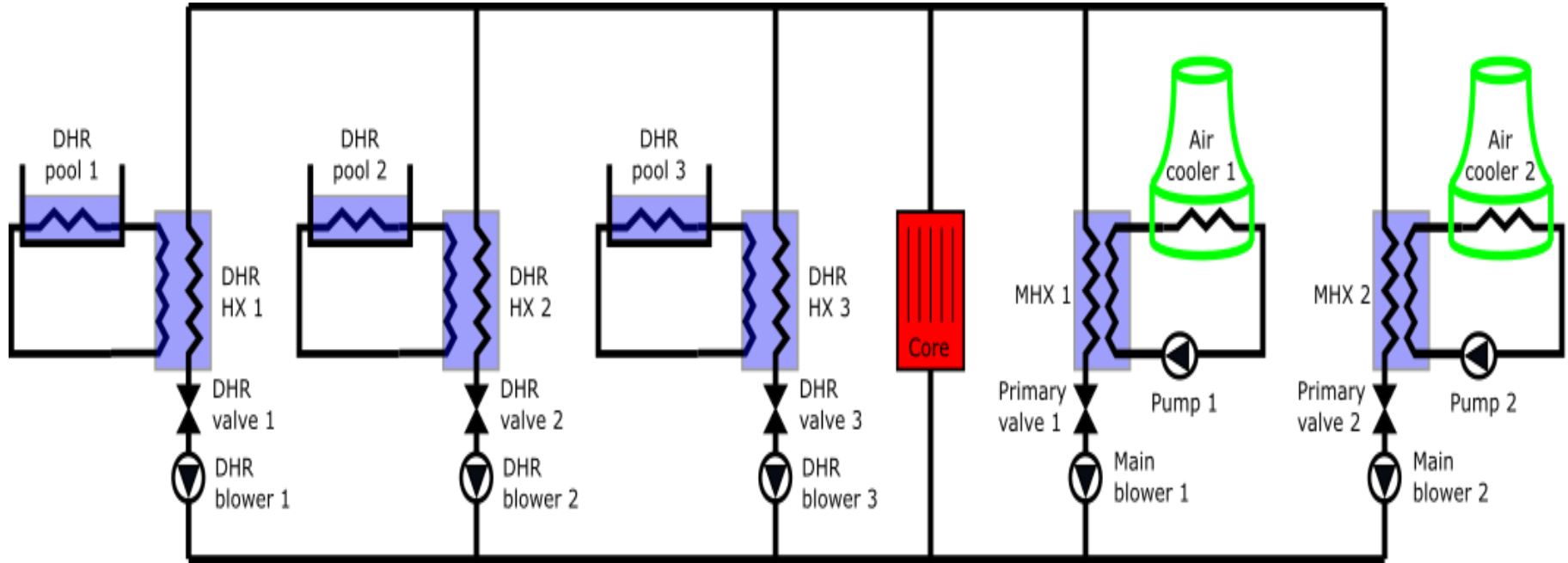

ETDR

The predecessor of ALLEGRO

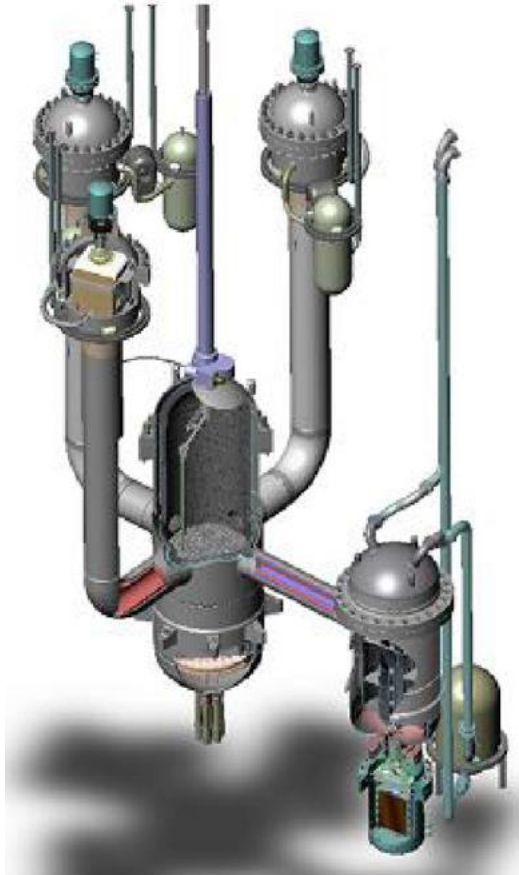

50 MWth
1 primary loop
3 DHRs

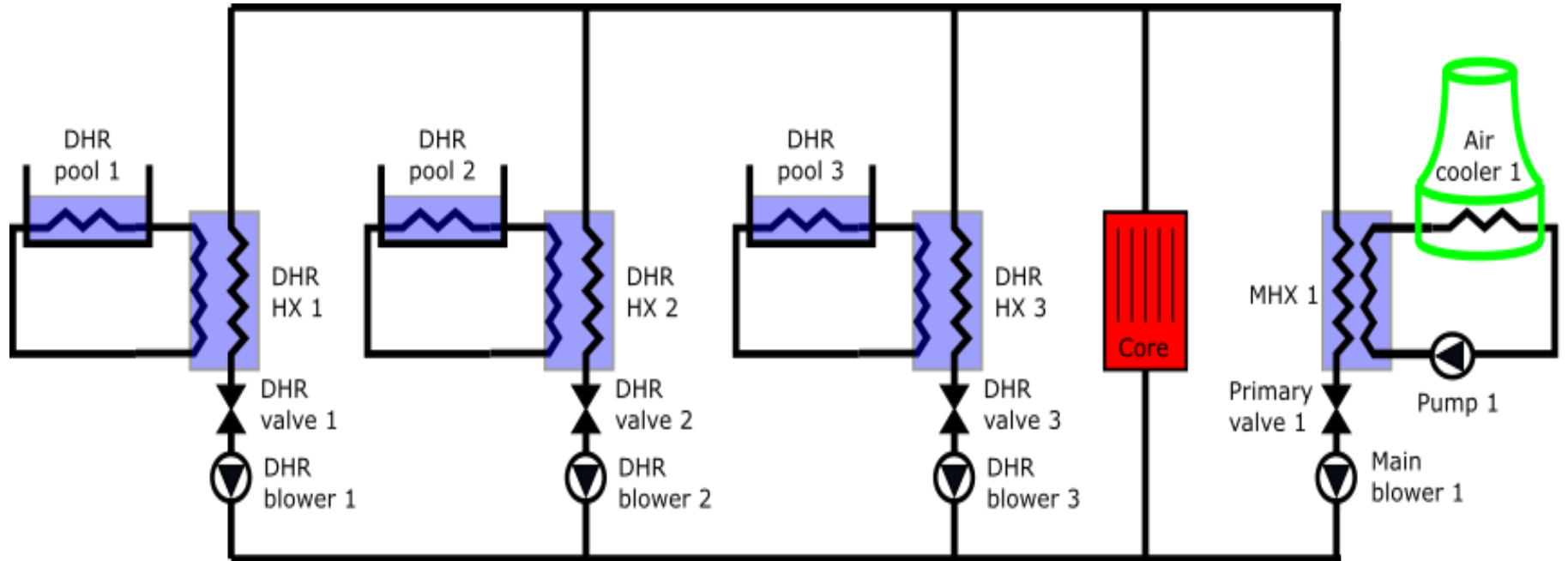

DHR strategy of ETDR

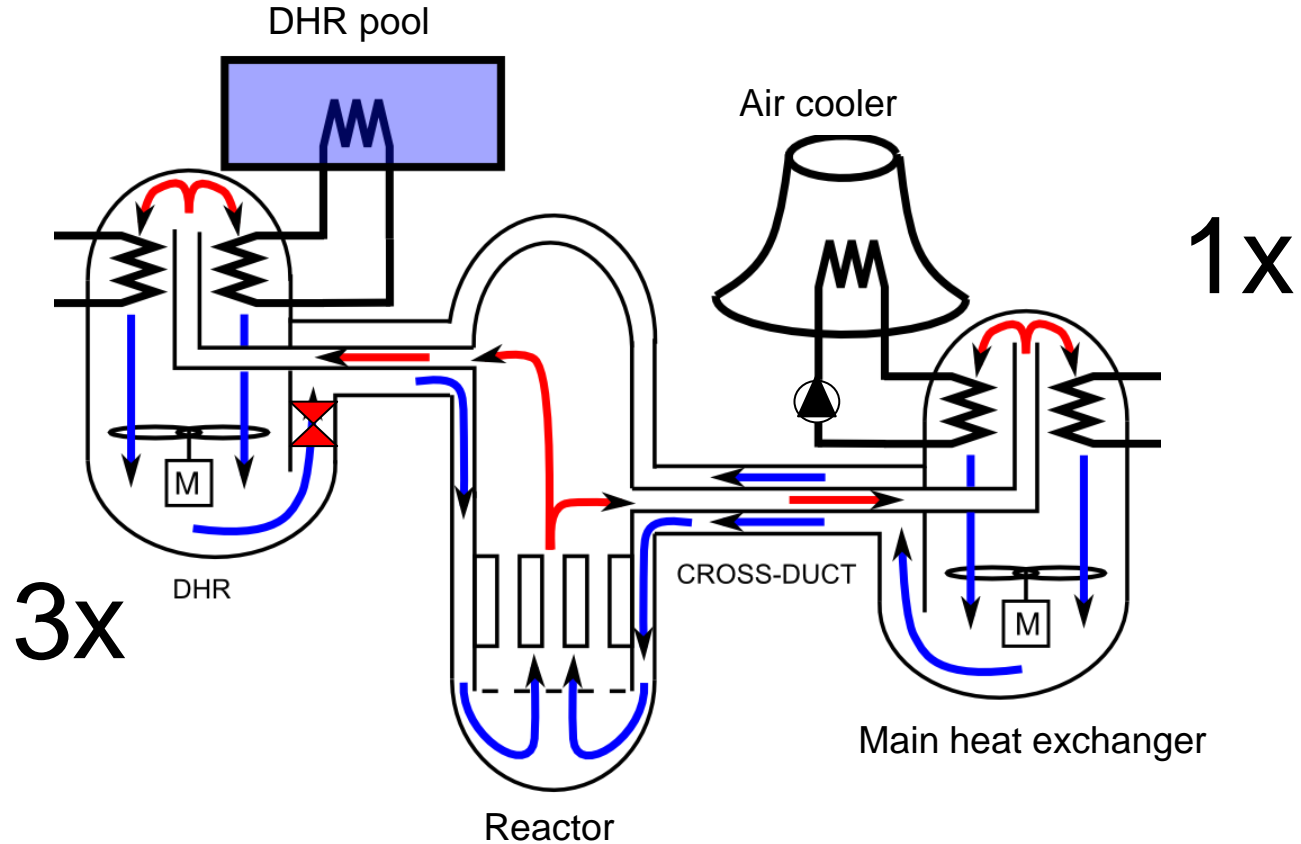

From ETDR to ALLEGRO. WHY?

C. Bassi et al. Level 1 probabilistic safety assessment to support the design of the CEA 2400 MWth gas-cooled fast reactor, NED, 240, 3758, 2010

PSA Study

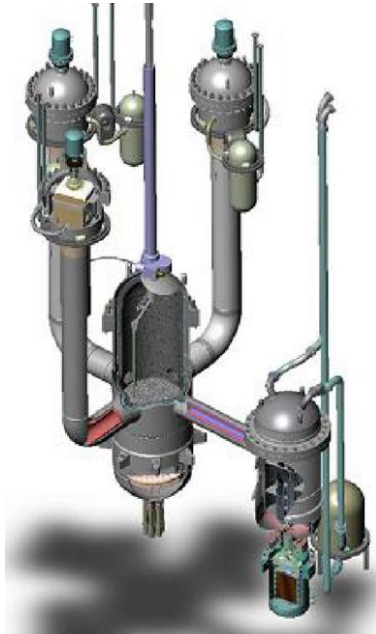

ETDR 50 MW

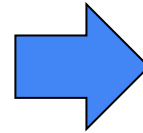

50 MW -> 75 MW
1 loop -> 2 loops
Pony motors
DHR -> DEC cases

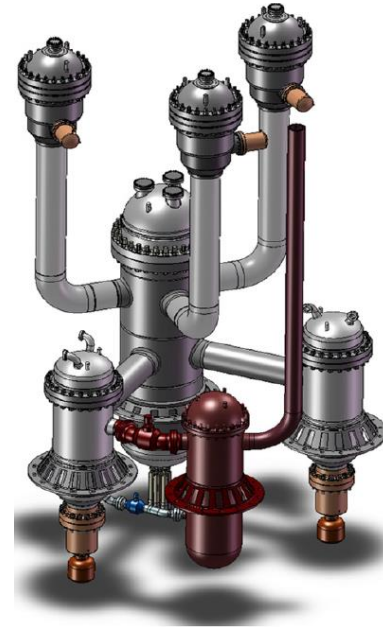

ALLEGRO 75 MW

DHR strategy of ALLEGRO

Decay Heat Removal system - DHR

- Blowers are used if there is electric power
- It could work as a passive system in pressurized conditions
- 300% redundancy

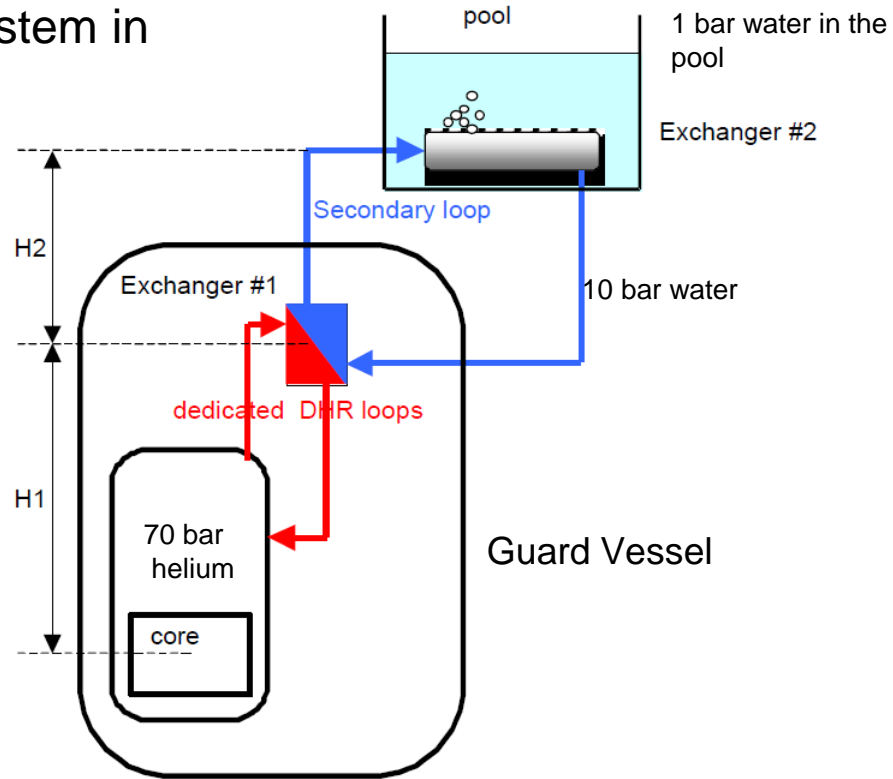
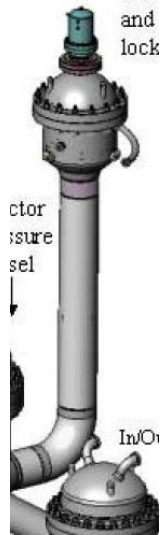

Hot and cold duct break

A decorative pattern of small, semi-transparent teal circles is scattered across the lower half of the slide, creating a subtle background effect.

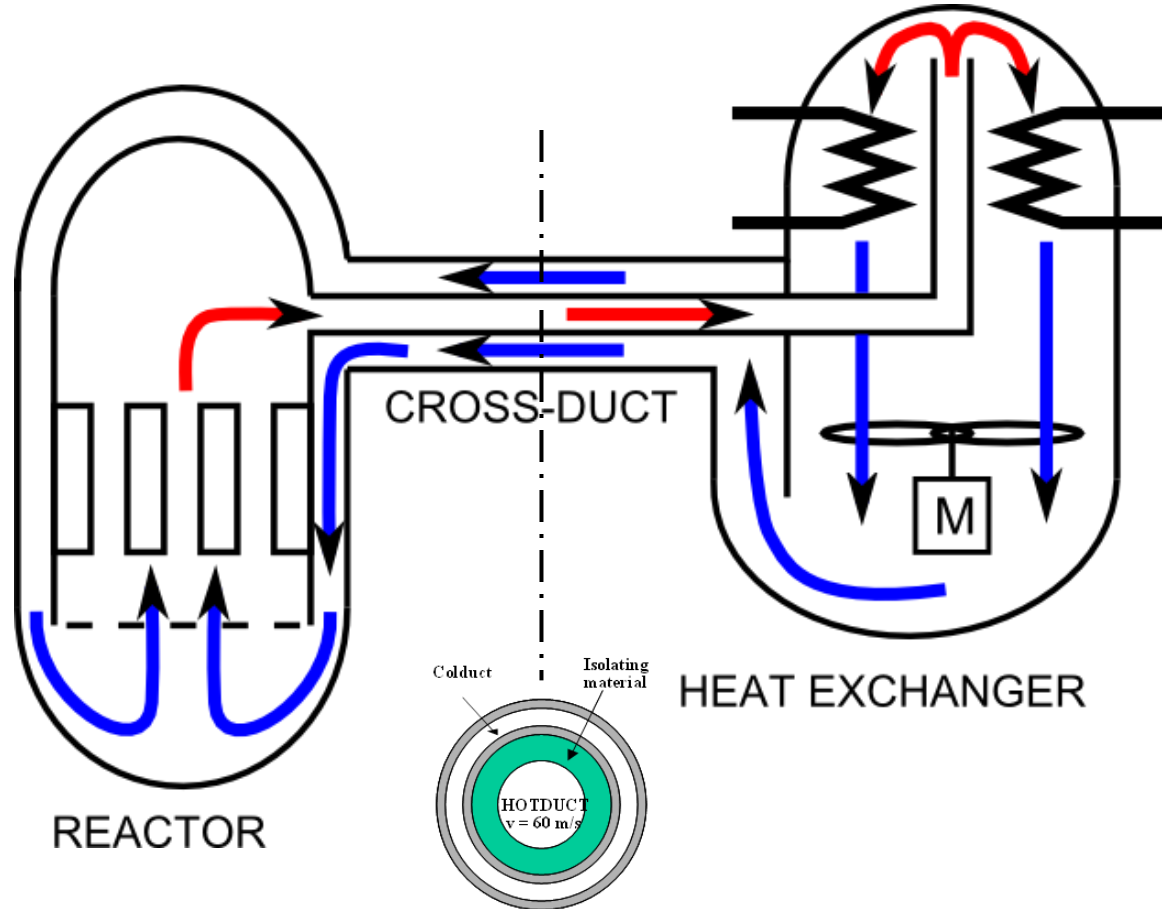

Hot and cross duct breaks

Pressure loss coefficient is important

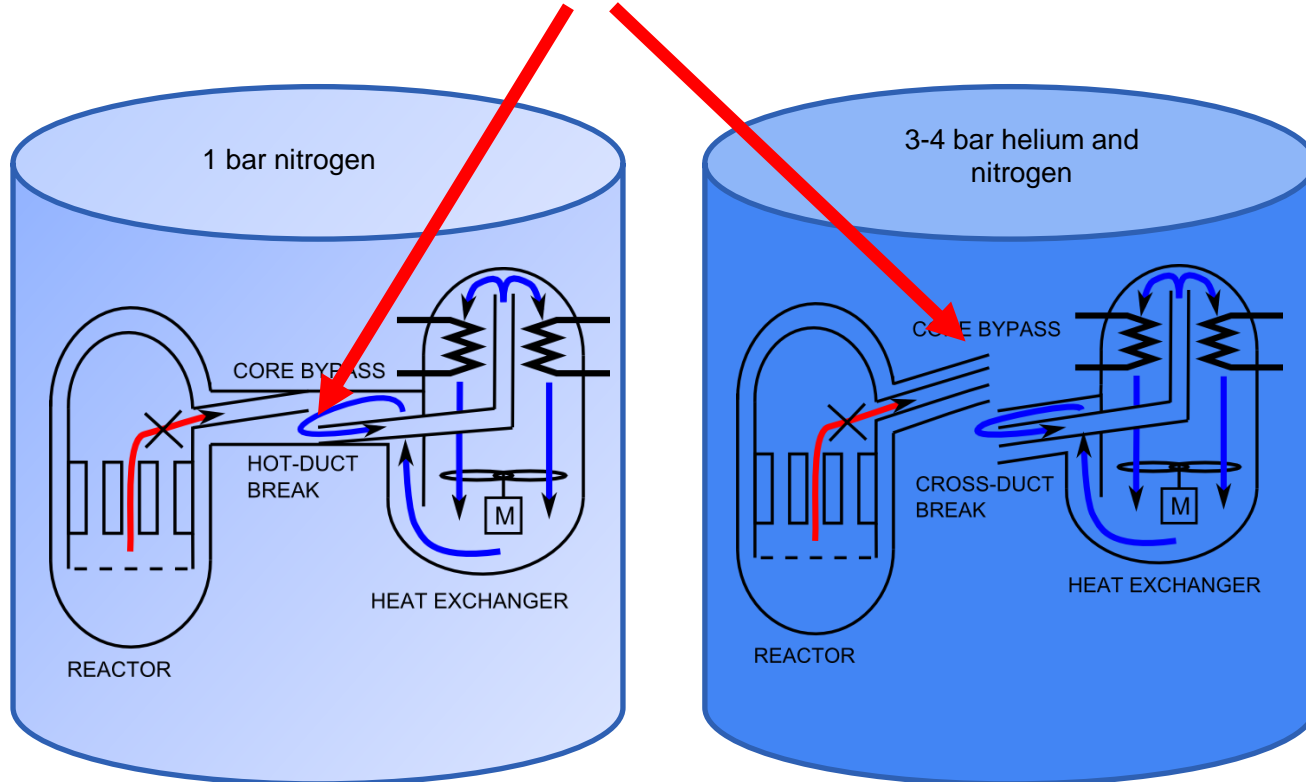

Hot and cold duct break model

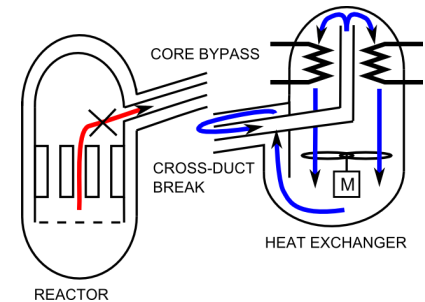
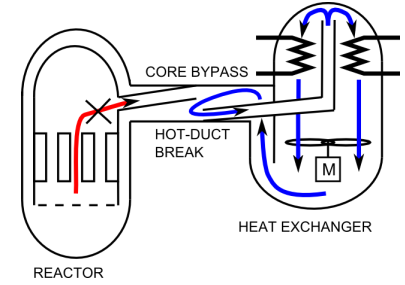
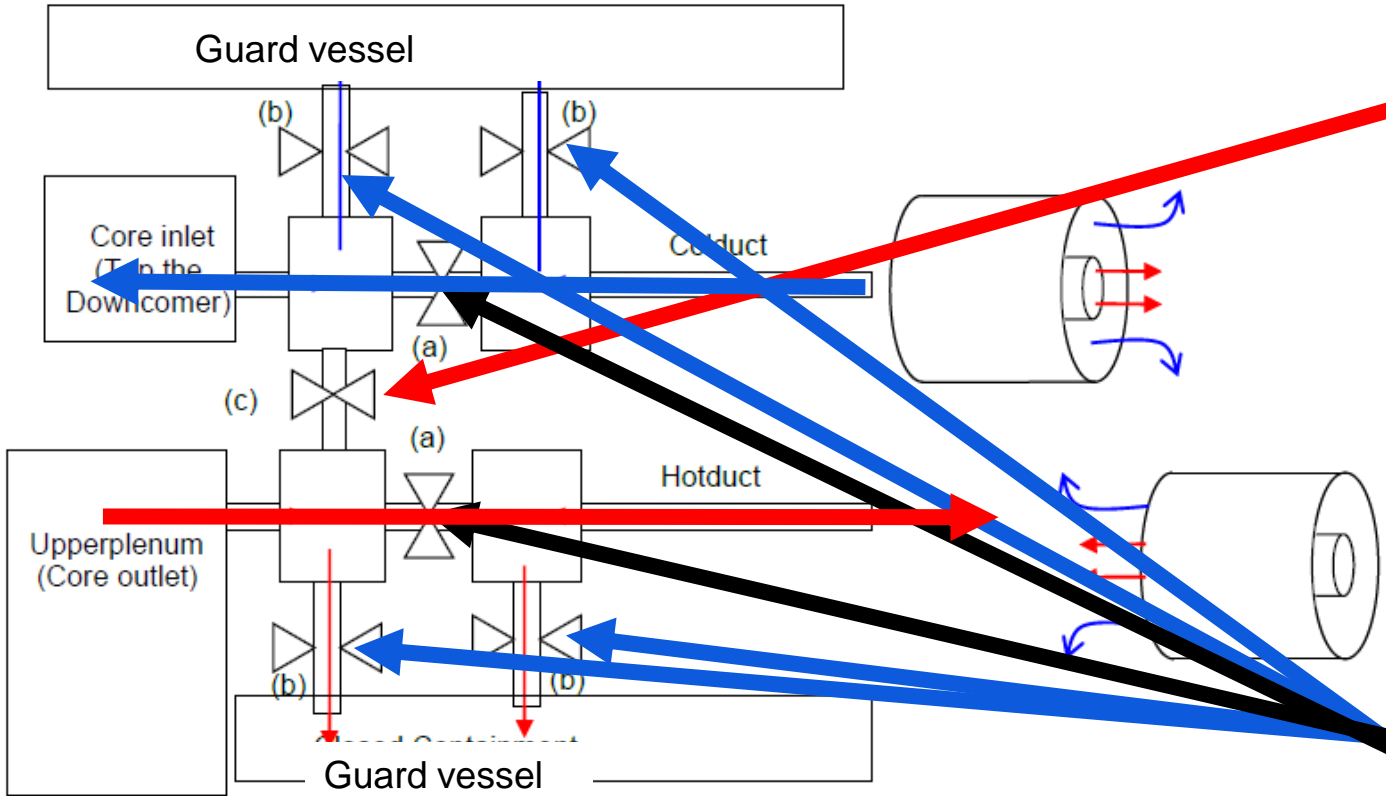

Hot and cold duct break model

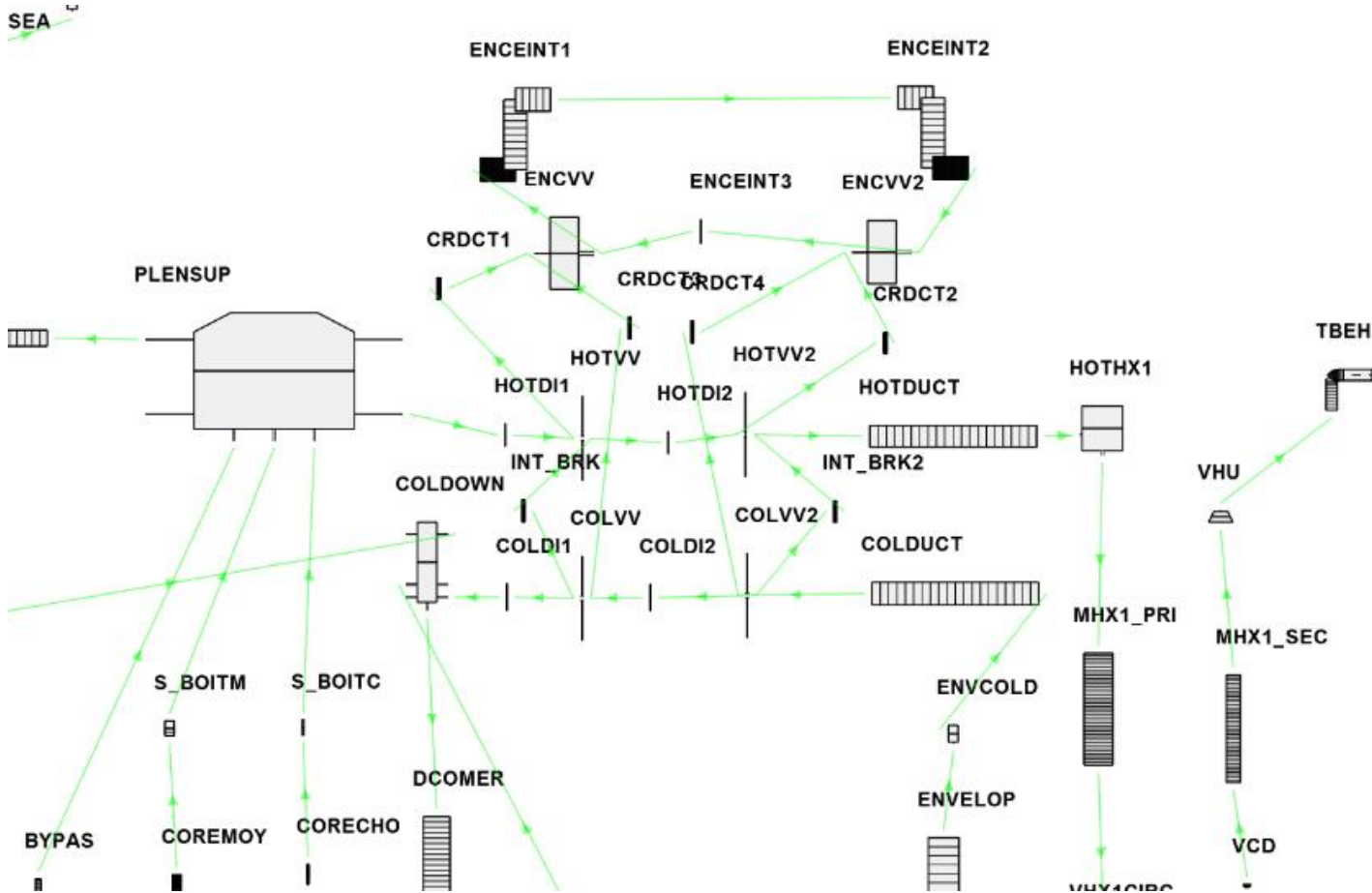

Hot duct break 200%, CFD study

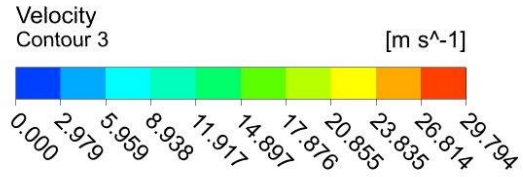

Blower
HX



Reactor
Porous
media

200% hot duct break

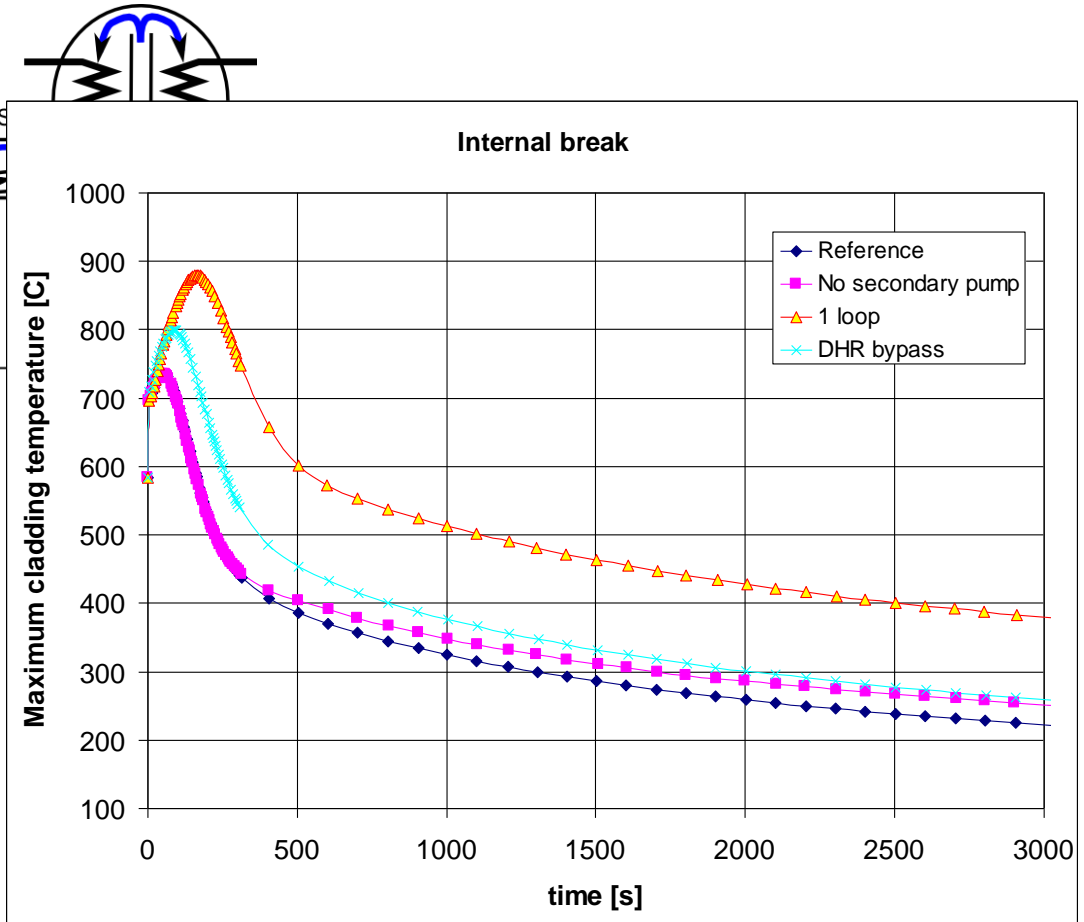
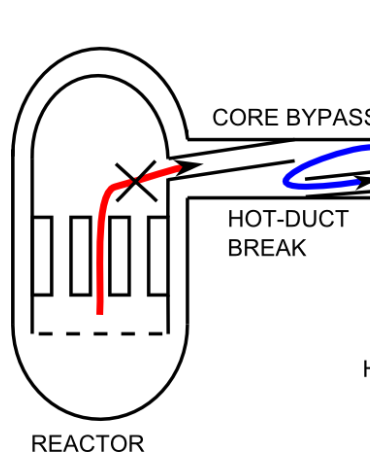

Hot and cold duct break 200%

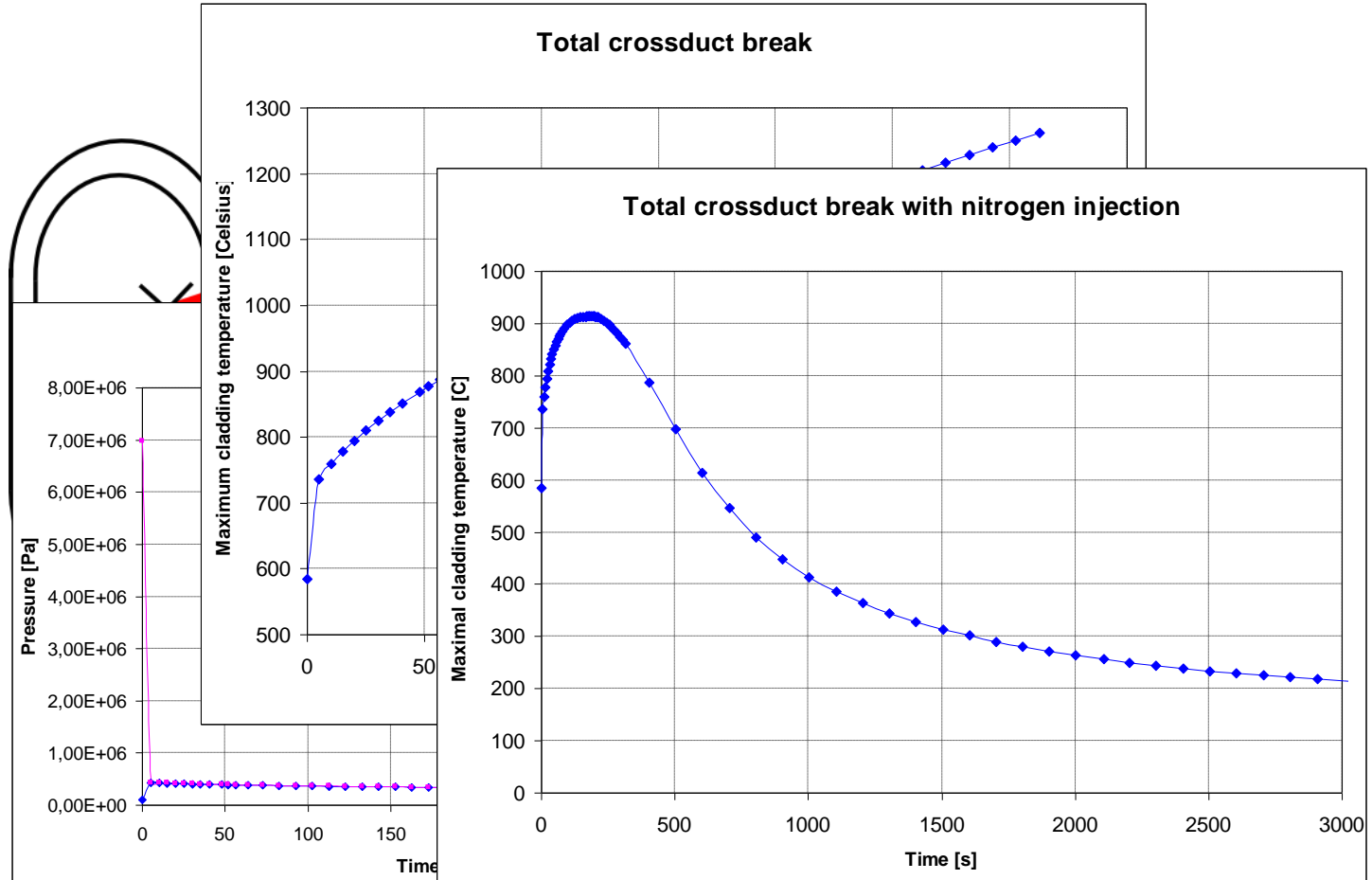

N₂ injection



Adiabatic expansion of a gas



$P_1 = 70 \text{ bar}$

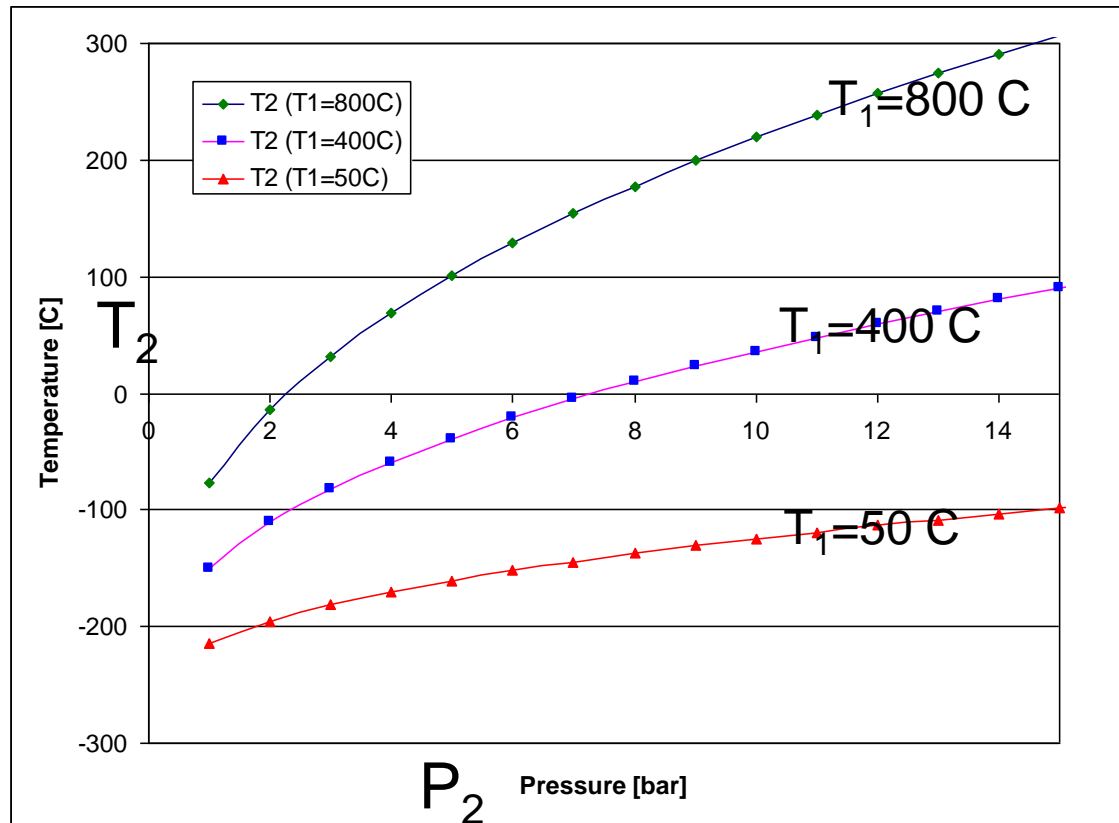

$$\frac{T_1}{T_2} = \left(\frac{P_1}{P_2} \right)^{\frac{\kappa-1}{\kappa}}$$

IE list

A decorative pattern of teal-colored dots of varying sizes is scattered across the bottom right portion of the slide, extending from the center towards the bottom right corner.

Goal

Finding the most limiting (enveloping) transients for ALLEGRO core optimization in SAFEG project

Main steps

1. Selection of a large number of initiating events (25)
2. CATHARE TH calculations -> Peak cladding temperatures
3. Final selection of maximum 4 IEs for core optimization in SAFEG based on TH calculations and engineering judgement

CATHARE Results

TR	Initiating event	Single failure	PCT			Cat.	Family	SCRAM
			Time	Value	Limit			
			s	C	C			
1	Inadvertent opening of DHR1 valve	DHR1 blower does not start	4	694	620	2	LOFA	Yes
2	Stop of MB1	MV1 does not close	0	600	620	2	LOFA	Yes
3	Stop of MB1 and MB2	MV1 does not close	0	620	735	3	LOFA	Yes
4	Inadvertent opening of DHR1 and DHR2 valves	DHR1 blower does not start	15	814	735	3	LOFA	Yes
5	Inadvertent opening of DHR1 and DHR2 valves	MBL1 stops	15	814	735	3	LOFA	Yes
6	Inadvertent opening of DHR1, DHR2 and DHR3 valve	DHR1 blower does not start	25	950	850	4	LOFA	Yes
7	Inadvertent opening of DHR1, DHR2 and DHR3 valve	MBL1 stops	25	950	850	4	LOFA	Yes
8	Inadvertent closure of MV1	DHR1BL does not start (DHR1V open)	20	740	620	2	LOFA	Yes
9	Inadvertent closure of MV1 and MV2	DHR1 blower does not start	30	870	735	3	LOFA	Yes
10	Inadvertent opening of DHR1, DHR2, DHR3 valves	DHR1 blower does not start	45	950	1300	A	LOFA	Yes
11	Secondary break 10 inch. (excessive core cooling)	DHR1BL does not start (DHR1V open)	5	747	850	4	LOCA	Yes
12	3 inch LOCA	DHR3 valve does not open	650	1242	1300	A	LOCA	Yes
13	Total Station Blackout	MV1 does not close	360	740	1300	A	SBO	Yes
14	Hot duct break 100% in LOOP1	MBL2 stops	250	1100	850	4	LOFA	Yes
15	Hot duct break 100% in LOOP1	DHR1V open (DHR1BL does not start)	210	1130	850	4	LOFA	Yes
16	LOCA 10 inch	DHR1V open (DHR1BL does not start)	110	1026	850	4	LOCA	Yes
17	LOFA 20% blower speed	DHR1V open (DHR1BL does not start)	10	740	735	3	LOFA	Yes
18	Total cross duct break (with nitrogen inj. 15 bar)	No signal to start ACCU	150	950	1300	A	LOCA	Yes
19	Control rod ejection (1\$ in 0.1s)	DHR1V open (DHR1BL does not start)	2	1300	850	4	TOP	Yes
20	3 inch cold duct LOCA	UNPROTECTED	70	1200	1300	A	ULOCA	No
21	Stop of MB1 and MB2	UNPROTECTED	30	1180	1300	A	ULOFA	No
22	Rod group withdrawal (1\$ in 20s)	UNPROTECTED	>5000	1200	1300	A	UTOP	No
23	DHR1V open + DHR1BL not start	UNPROTECTED	10	775	1300	A	ULOFA	No
24	3 inch hot duct break	UNPROTECTED	10	610	1300	A	ULOFA	No
25	Instantaneous blockage of MBL1 (5 s) (deblading)	DHR1V open (DHR1BL does not start)	10	685	850	4	LOFA	Yes

The 4 selected transients for core optimization in SAFEG WP1 (Different families)

Heated parallel pipes

The background of the slide is a dark teal color with a pattern of glowing, semi-transparent blue circles of varying sizes, scattered across the lower half of the page.

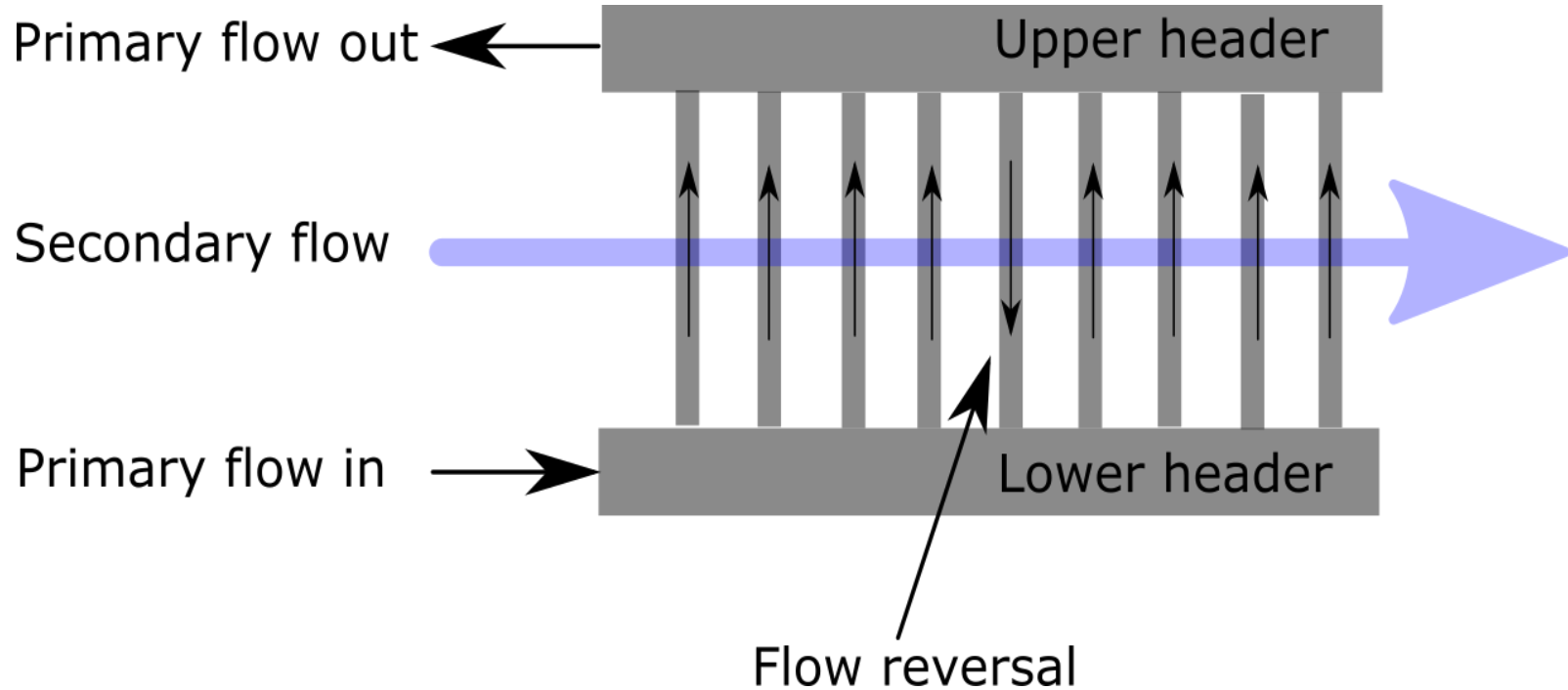

Reactor, heated parallel pipes

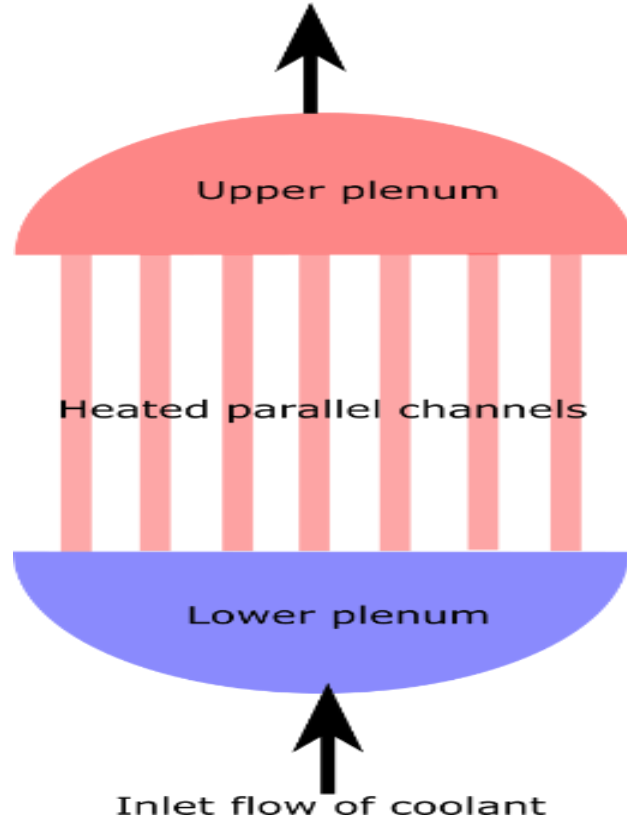

Two vertical parallel pipes

Pressure boundary condition

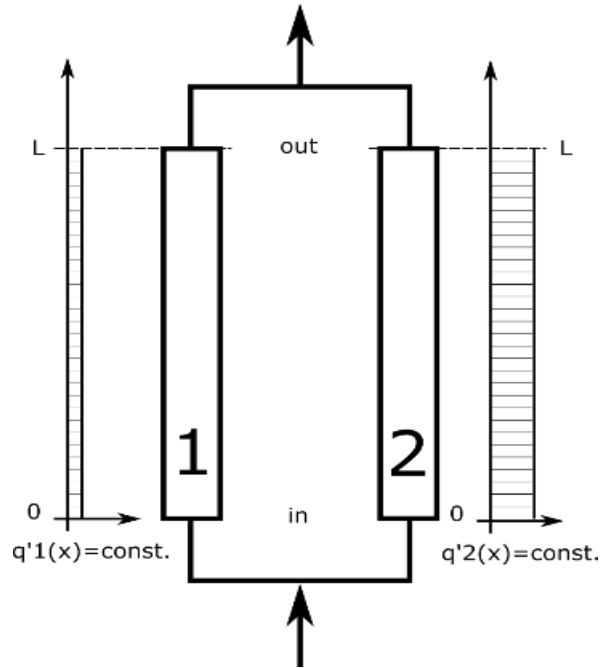

Mass flow rate boundary condition

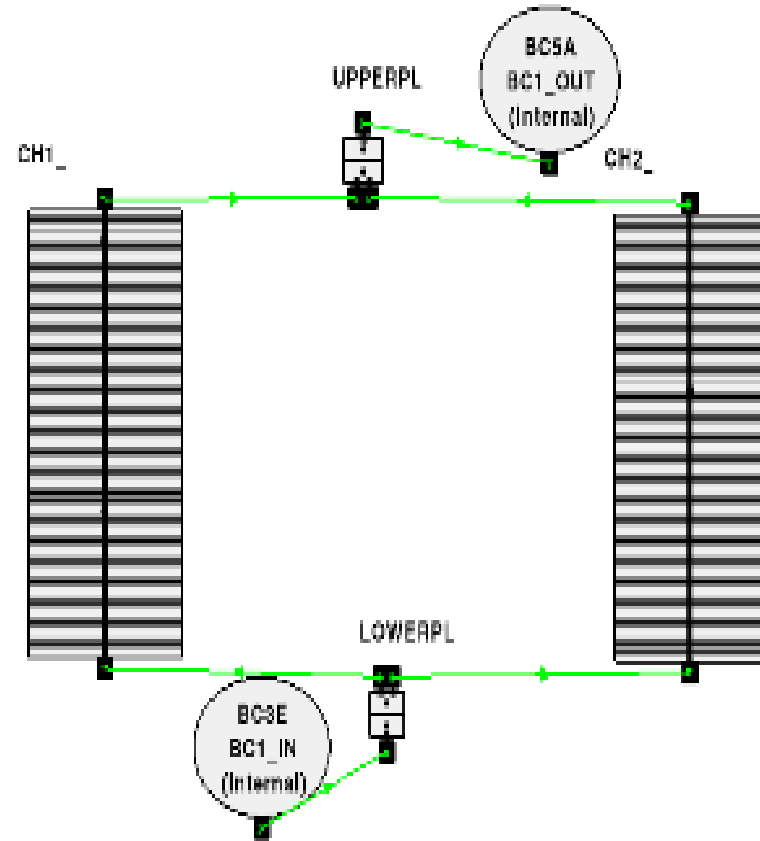

ALLEGRO – gas-cooled fast reactor demonstrator SafeG[®]

The mass flow rate ratio of channel 1 and channel 2 (\dot{m}_1/\dot{m}_2) in the function of total inlet mass flow rate ($\dot{m}_1 + \dot{m}_2$) [kg/s]. The heating power of 1st channel is fixed to 200 W, and 2nd channel power is shown by the color bar.

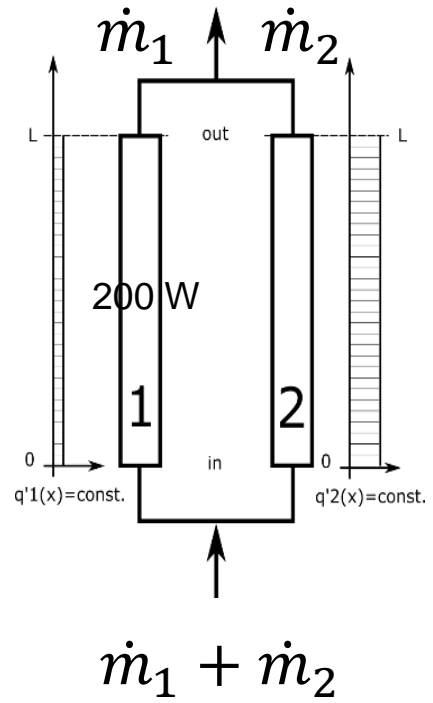
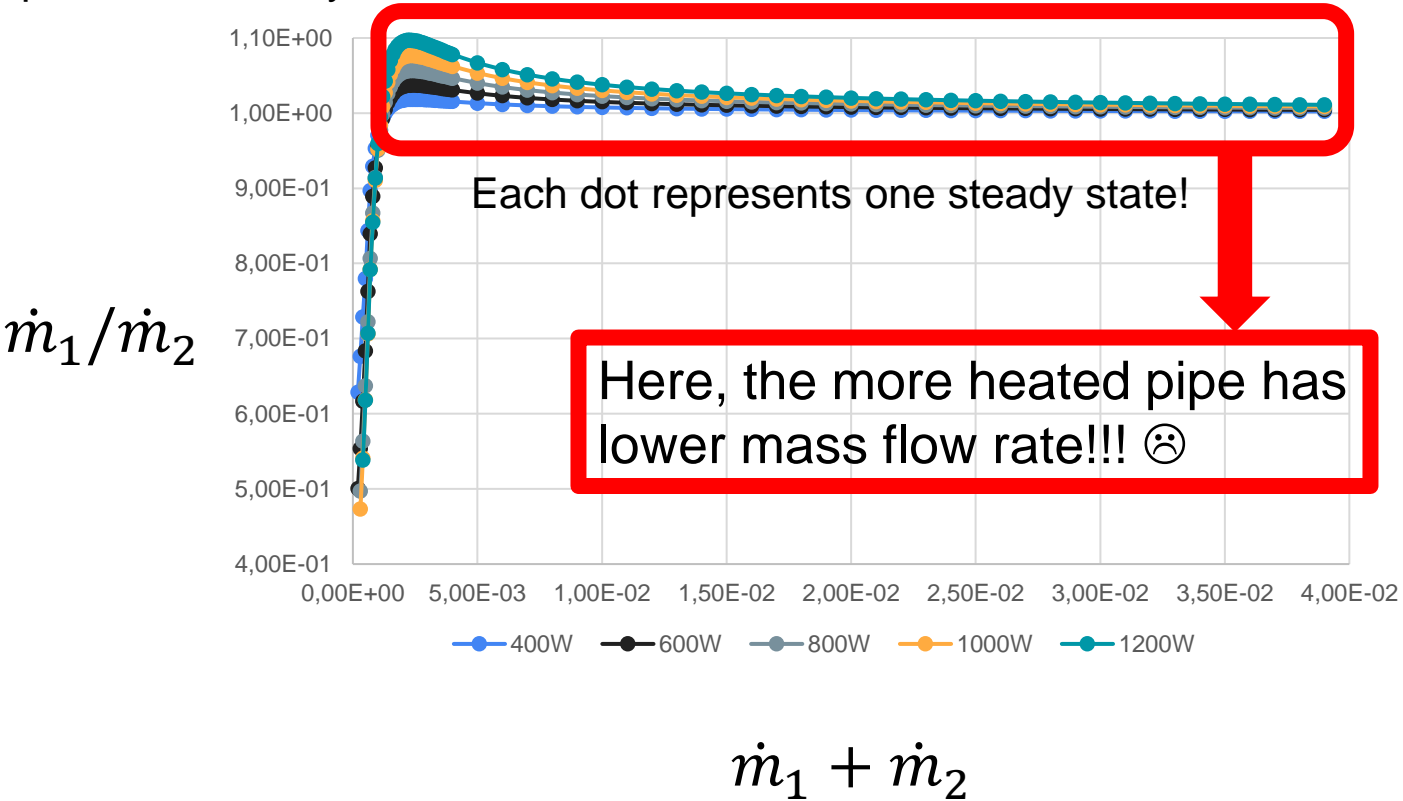

Three-loop ALLEGRO

The background of the slide is dark teal with a pattern of lighter teal dots of varying sizes, scattered across the lower half of the page.

Three-loop ALLEGRO

SafeG[®]

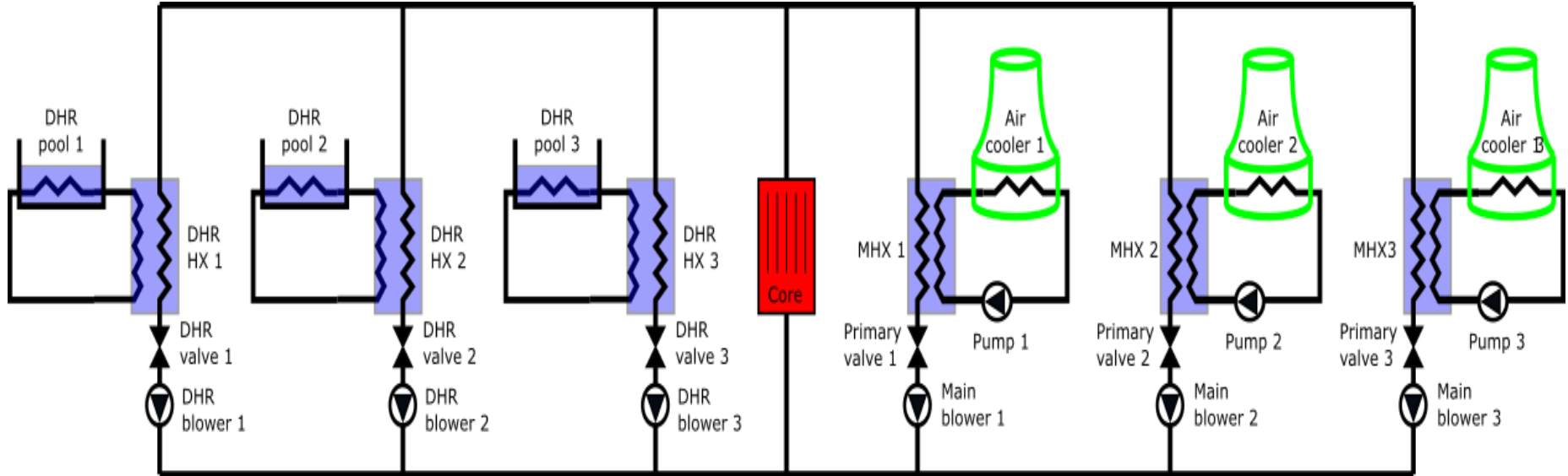

Three-loop ALLEGRO, hot duct break, maximum cladding temperature

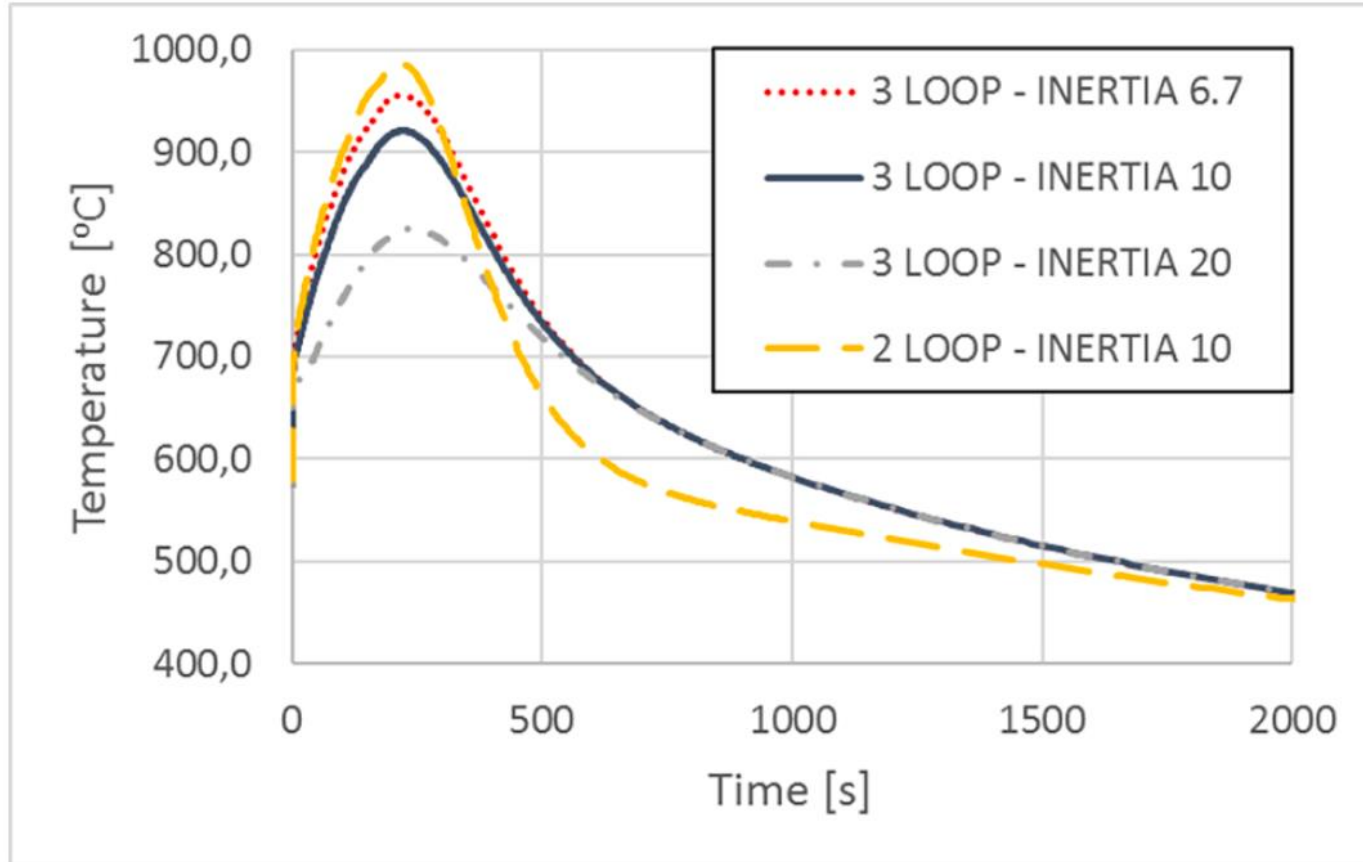

Summary

- Building a GFR is a big challenge
- New solutions raise new problems
- Careful planning is required

Thank you for your attention!

Gusztáv Mayer, EK, gusztav.mayer@ek-der.hu

The logo for vuje, featuring the word "vuje" in a blue, lowercase, sans-serif font.The logo for BriVaTech, featuring the text "BriVaTech" in white on a blue rectangular background.The logo for Jacobs, featuring the word "Jacobs" in a bold, black, sans-serif font.The logo for evalion, featuring the word "evalion" in a black, lowercase, sans-serif font with a green speech bubble icon to its right.The logo for the University of Cambridge, featuring a red shield with a white cross and the text "UNIVERSITY OF CAMBRIDGE" to its right.The logo for STU, featuring the letters "STU" in a bold, black, sans-serif font with a grid of dots to its left and the text "SLOVENSKÁ TECHNICKÁ UNIVERZITA V BRATISLAVE" below it.The logo for Műegyetem 1782, featuring a black silhouette of a building and the text "MŰEGYETEM 1782" below it.

SafeG GFR Summer School

Husinec-Rez, Czech Republic, 20.08. 01.09.2022

History and Development of HTRs

Dr. Gerd Brinkmann

**BriVaTech Consulting
Andreas-Sapper-Str. 15
91334 Hemhofen**

phone: +49 9195994747

mail: gerd.brinkmann@gmx.de

HTRs History

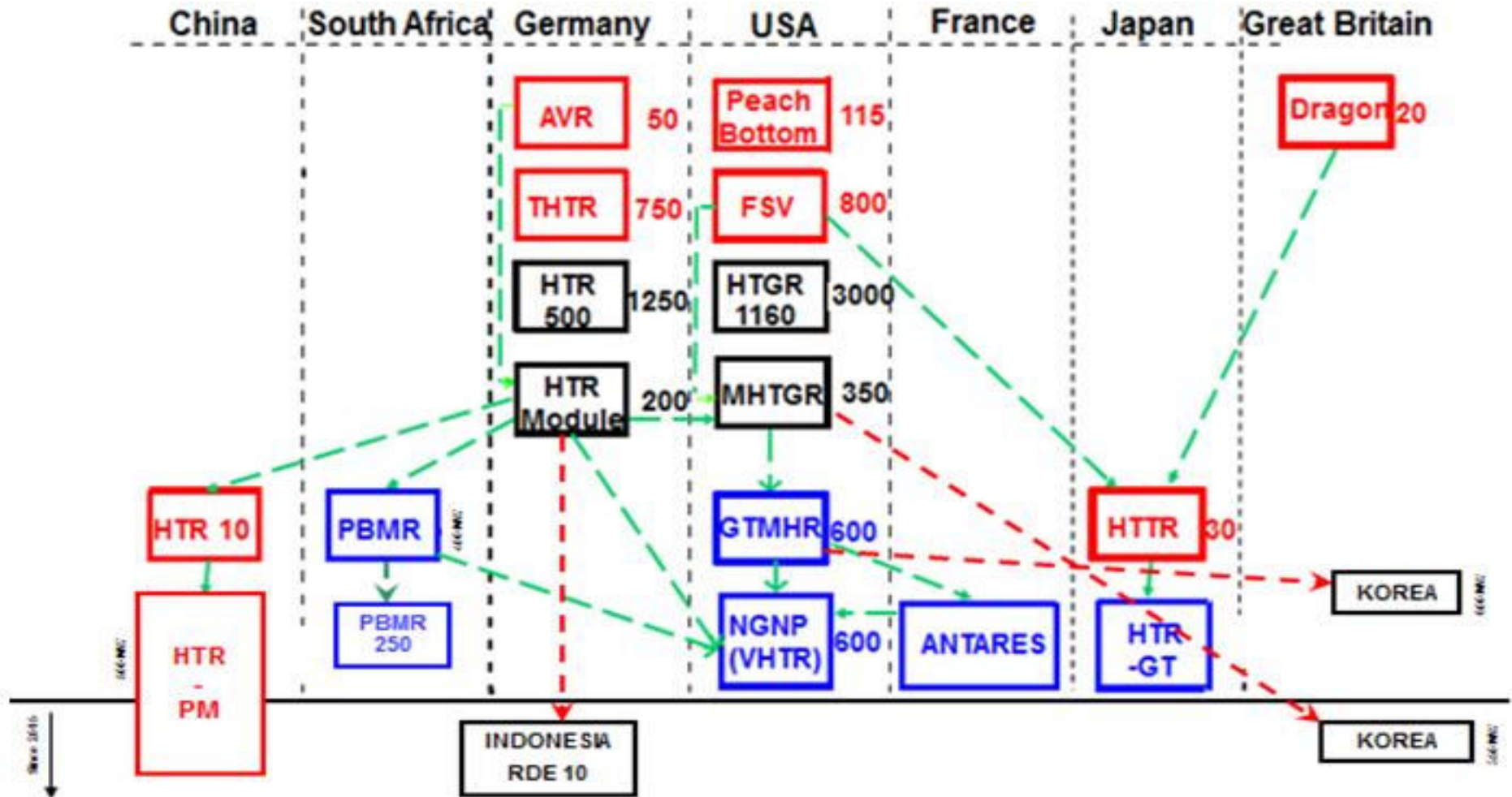

HTRs Fuel Element Designs

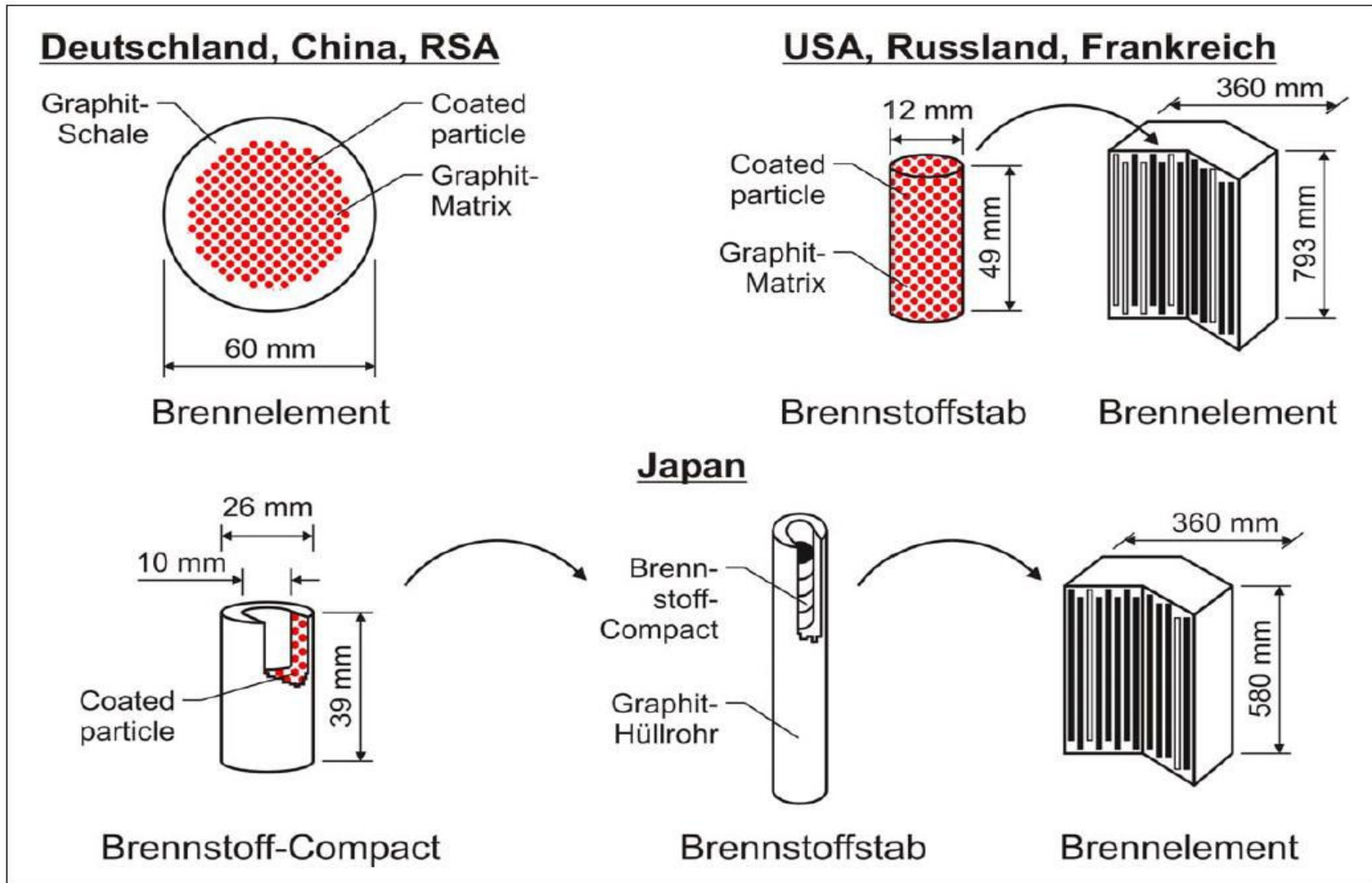

HTR Fuel Element (Pebble)

Pebble Bed

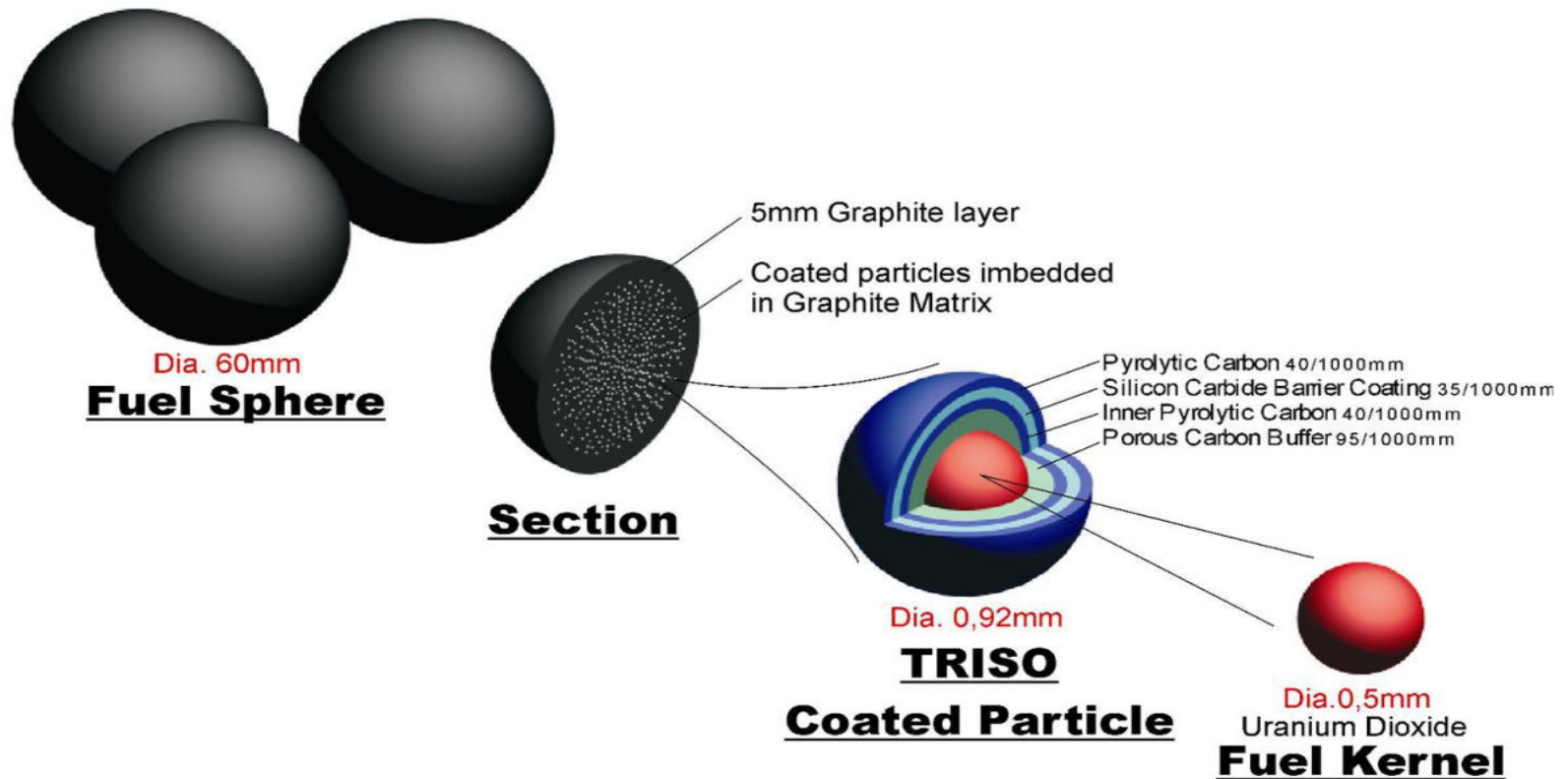

HTGRs Fuel Element (Block)



Brennstoff-Compacts

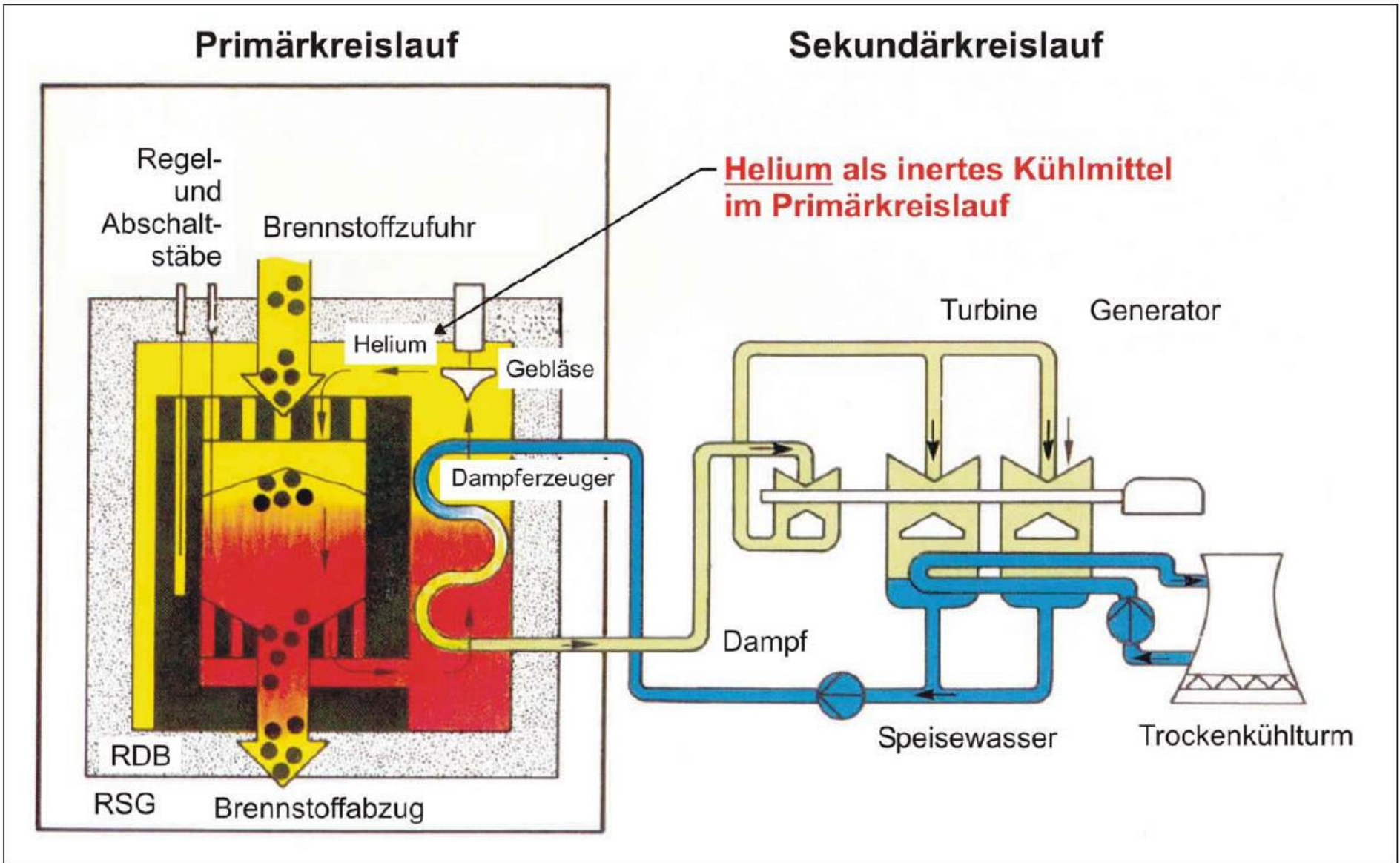

HTR-Applications

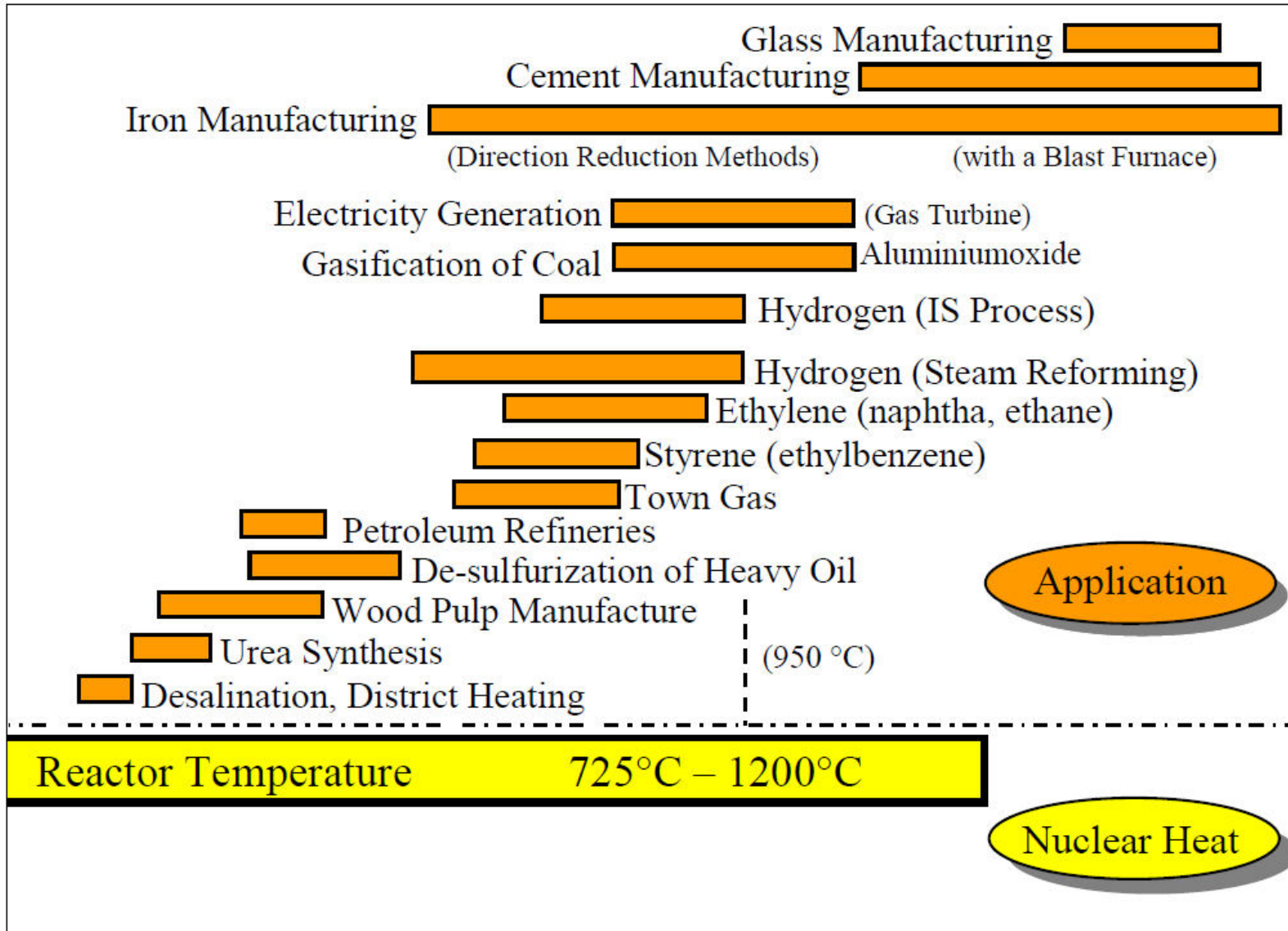

DRAGON Reactor in GB

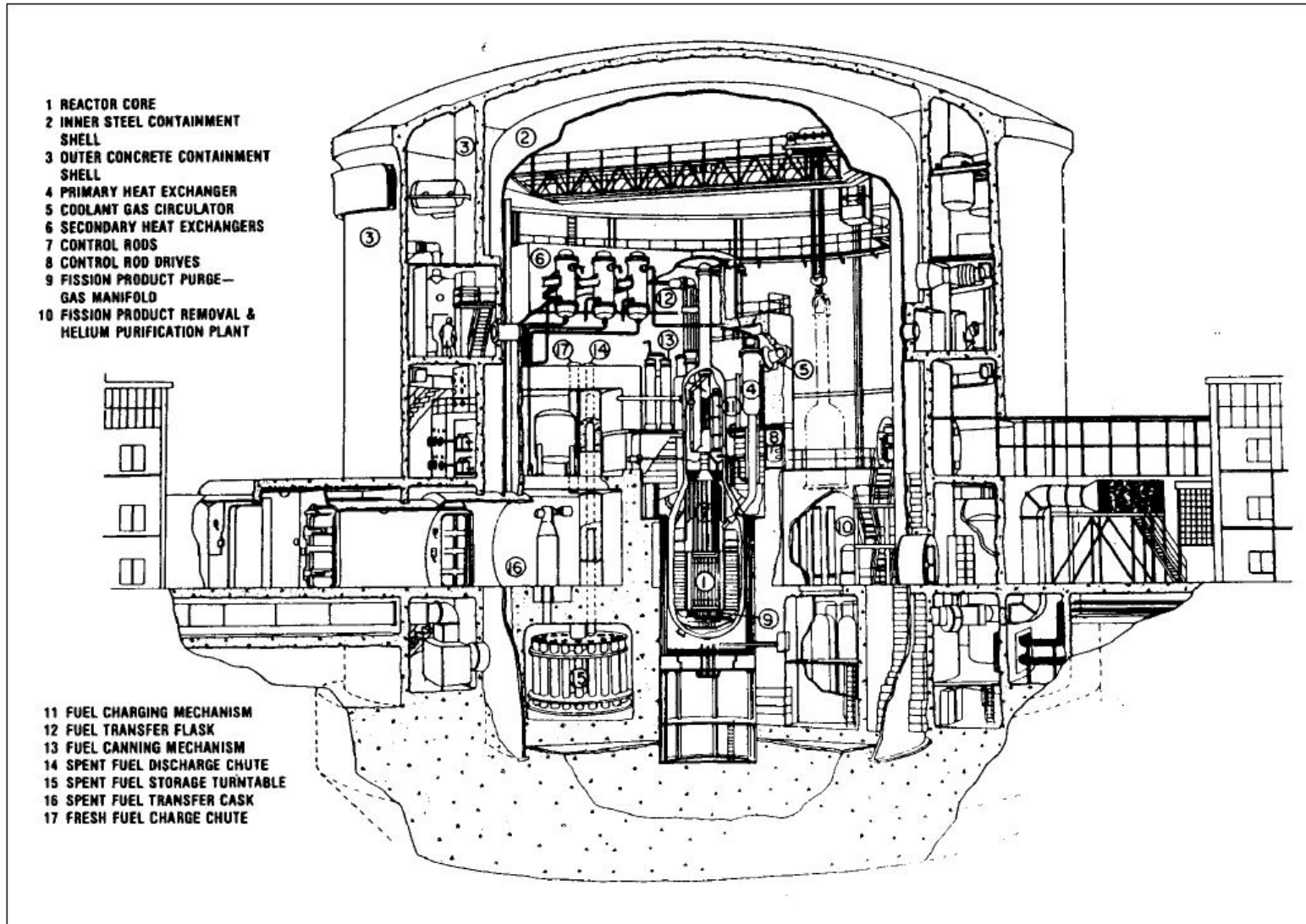

- **OECD Project (1964-1975)**
- **20 MW_{th}**
- **Helium outlet temperature 750 °C**
- **Block fuel design**
- **Test bed for fuel irradiation and performance test**

Peach Bottom HTR-Prototype in USA

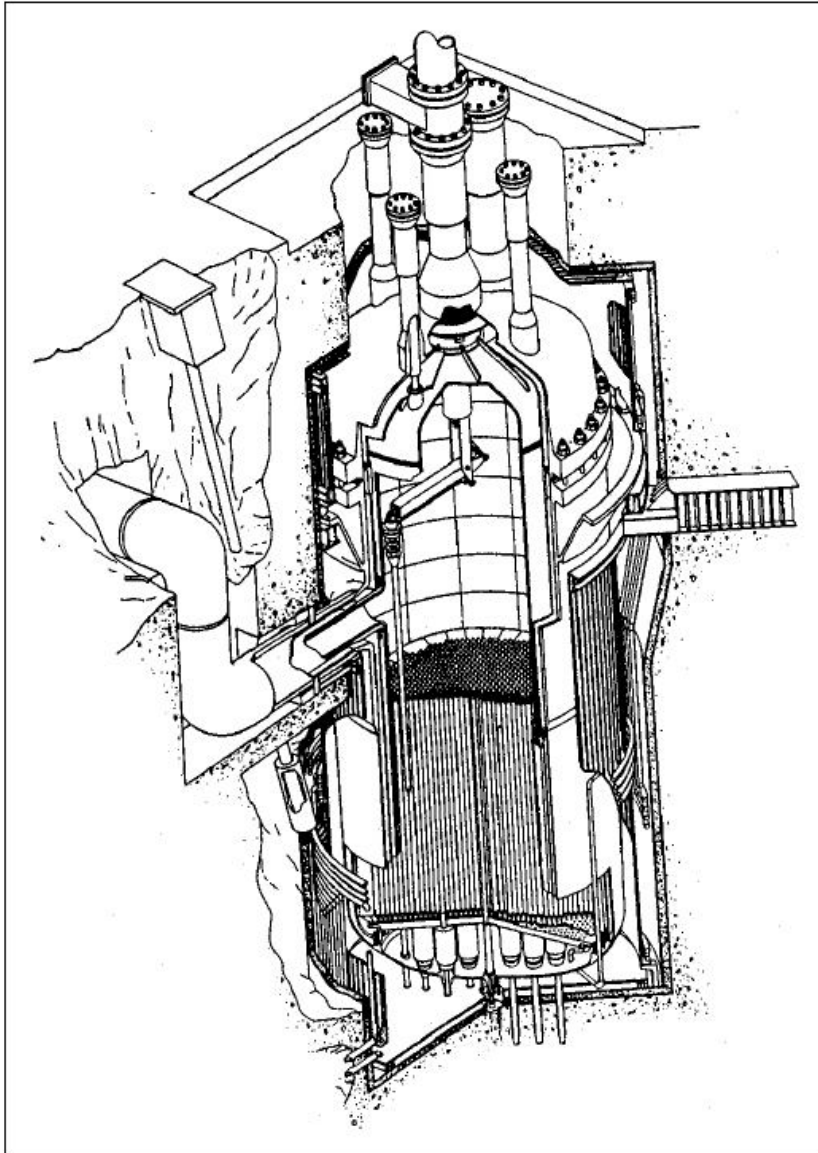

- ***115 MW_{th} / 40 MW_{et} steam circuit (1967 – 1974)***
- ***Block fuel design***
- ***Single coating fuel problematic (Core 1)***
- ***Biso coating fuel improved performance***

Fort Saint Vrain (FSV) HTR in USA

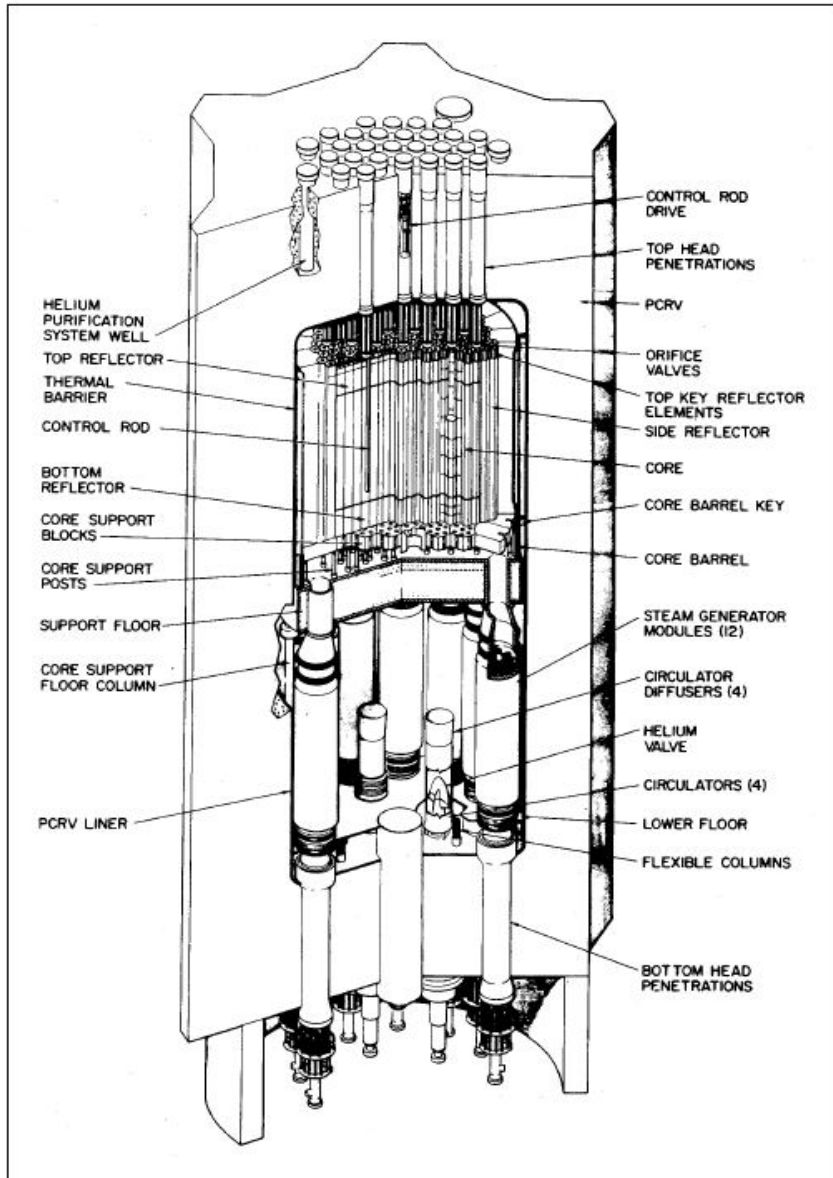

- **300 MW_e**
(1981 – 1988)
- **Followed Beach Bottom block fuel design**

Arbeitsgemeinschaft Versuchs-Reaktor (AVR) in Germany

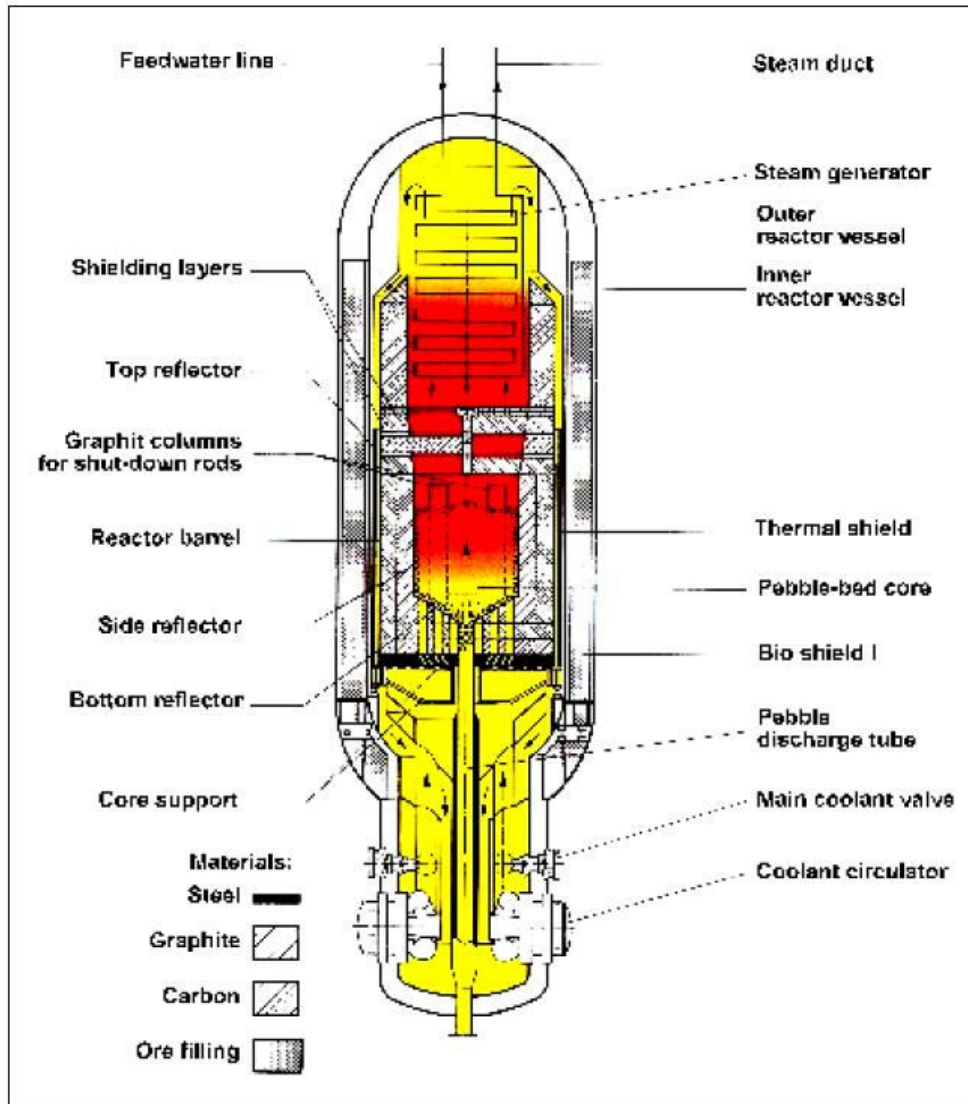

- **15 MW_e**
(1966 – 1988)
- **Bebble Bed concept**
- **Online refueling**
- **Helium outlet temperature up to 950 °C**
- **Demonstration of fuel particle confinement**

Thorium High Temperature Reactor (THTR-300) in Germany

Nuclear Power Plant Hamm-Uentrop THTR 300

- | | |
|--|---|
| 1 Reactor Core | 21 Reactor Hall Crane |
| 2 Graphite Reflector | 22 Control Rod Removal Cask |
| 3 Thermal Barrier | 23 Crane |
| 4 Prestressed Concrete Reactor Vessel | 24 Compressed-Air Plant |
| 5 Prestressing Cables | 25 High-Pressure Steam Pipes |
| 6 Steam Generator | 26 Ventilation Plant |
| 7 Helium Circulator | 27 Control Helium Pressure Tank
(in Building 32) |
| 8 In-Core Rod | 28 Helium Purification System |
| 9 Reflector Rod | 29 Helium Storage |
| 10 Start-Up Instrumentation | 30 Workshop |
| 11 Hot Gas Temperature Instrumentation | 31 High-Pressure Safety Valves |
| 12 n-Flux Distribution Instrumentation | 32 Access and Security Building |
| 13 Fuel Element Discharge Pipe | 33 Main Control Room |
| 14 Fuel Element Loading Facility | 34 Circulator Turbopump |
| 15 Burn-Up Measurement Reactor | 35 Auxiliary Feed Water Tank |
| 16 Fuel Element Loading Tubes | 36 Turbine Building Crane |
| 17 Fresh Fuel Element Storage | 37 Turbine |
| 18 Fuel Element Loading Facility | 38 Generator |
| 19 Fuel Element Discharge Facility | 39 Primary Cooling Water Pump |
| 20 Spent Fuel Element Storage | 40 Rotary Transformer |

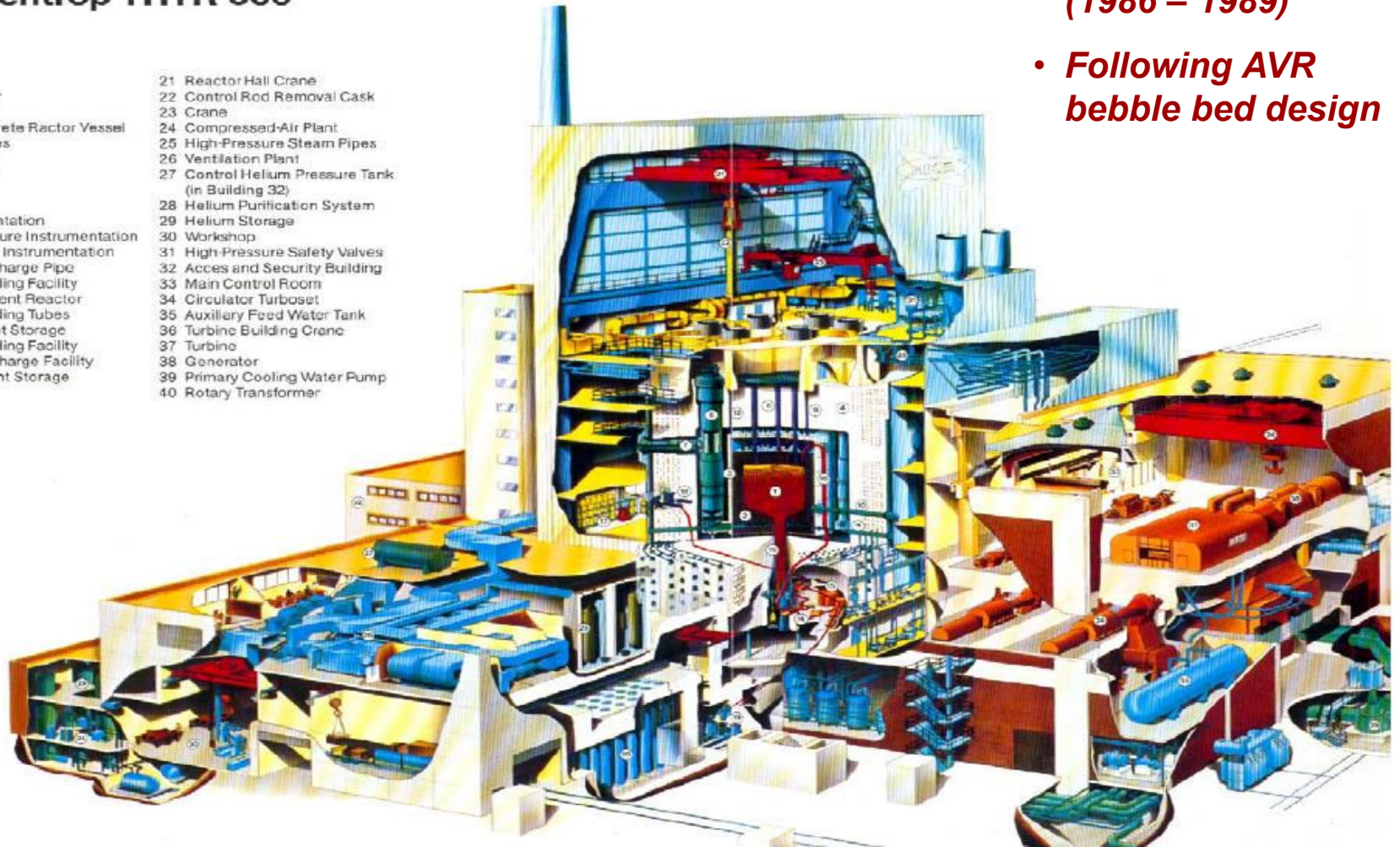

- 296 MW_e
(1986 – 1989)
- *Following AVR
bebble bed design*

HTR-10 in China



- *10 MW_e*
- *Bebble bed design*
- *First criticality in 2000*
- *In operation*

HTR-10 in China

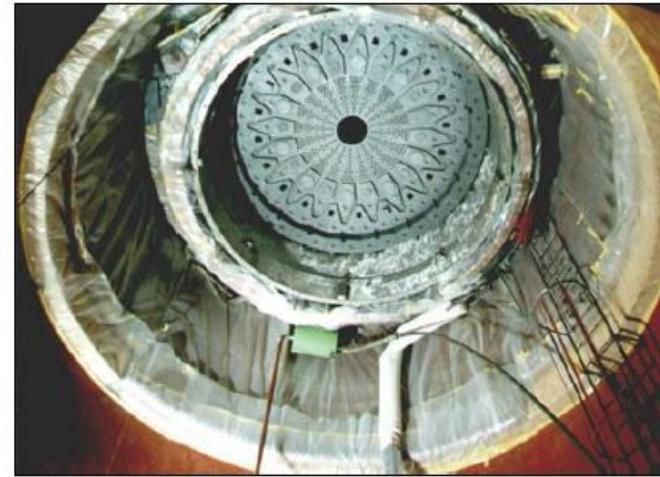
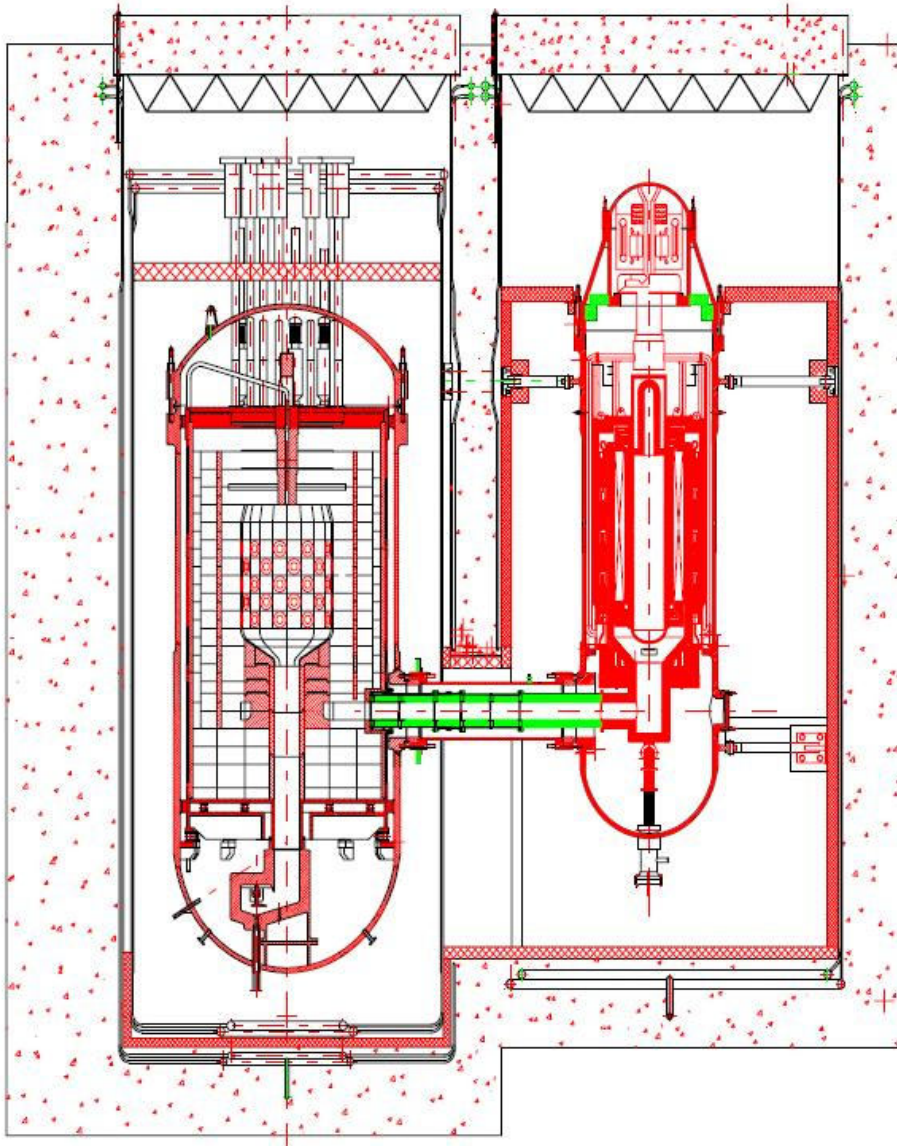

Top Reflector

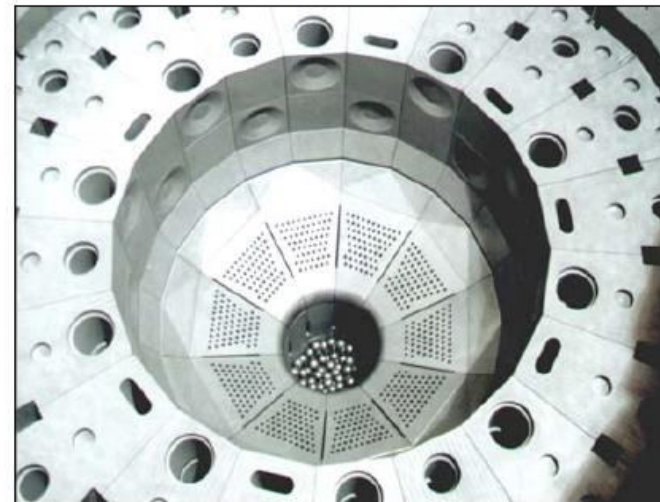

Bottom Reflector

HTR PM in China

In operation

Pebble Bed Design

Thermal capacity 2x250 MW

Electrical capacity 210 MW

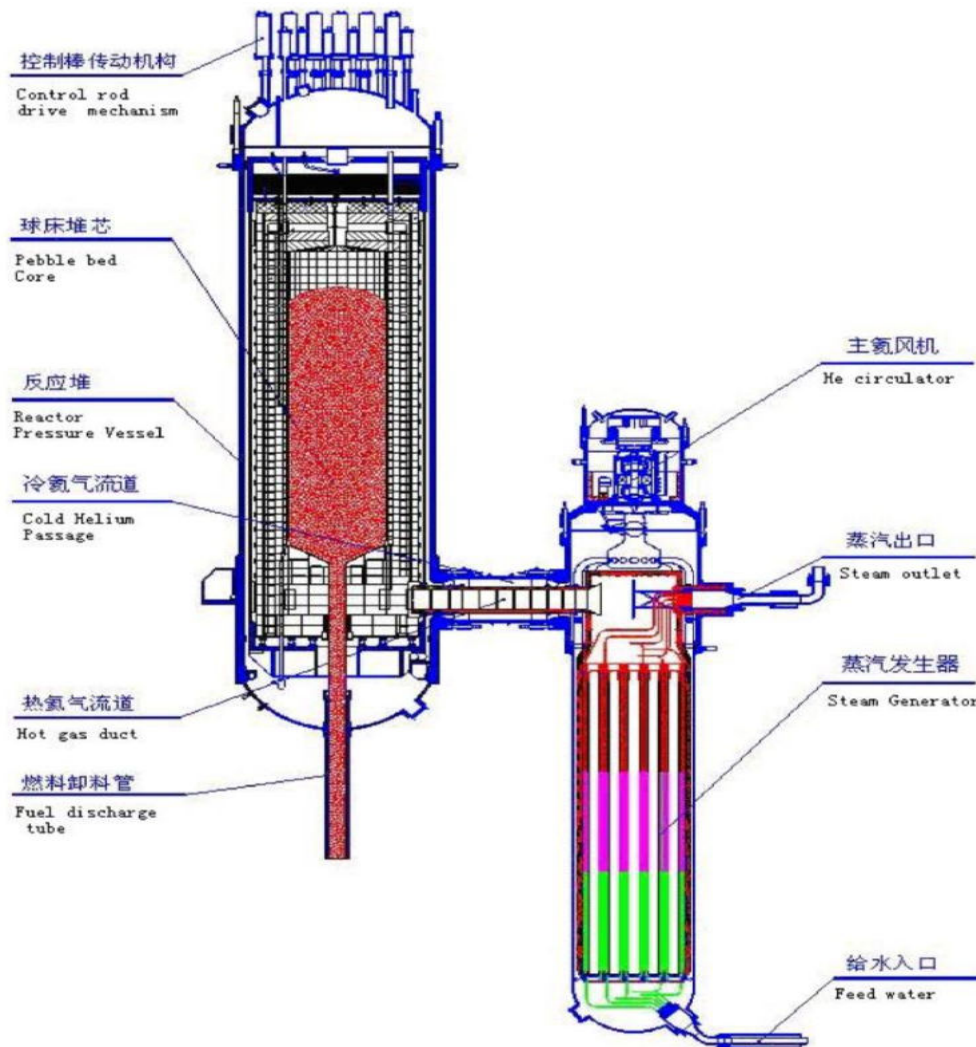

HTTR in Japan



- 30 MW_e
- *Block design*
- *First criticality in 1998*
- *In operation*

HTTR in Japan

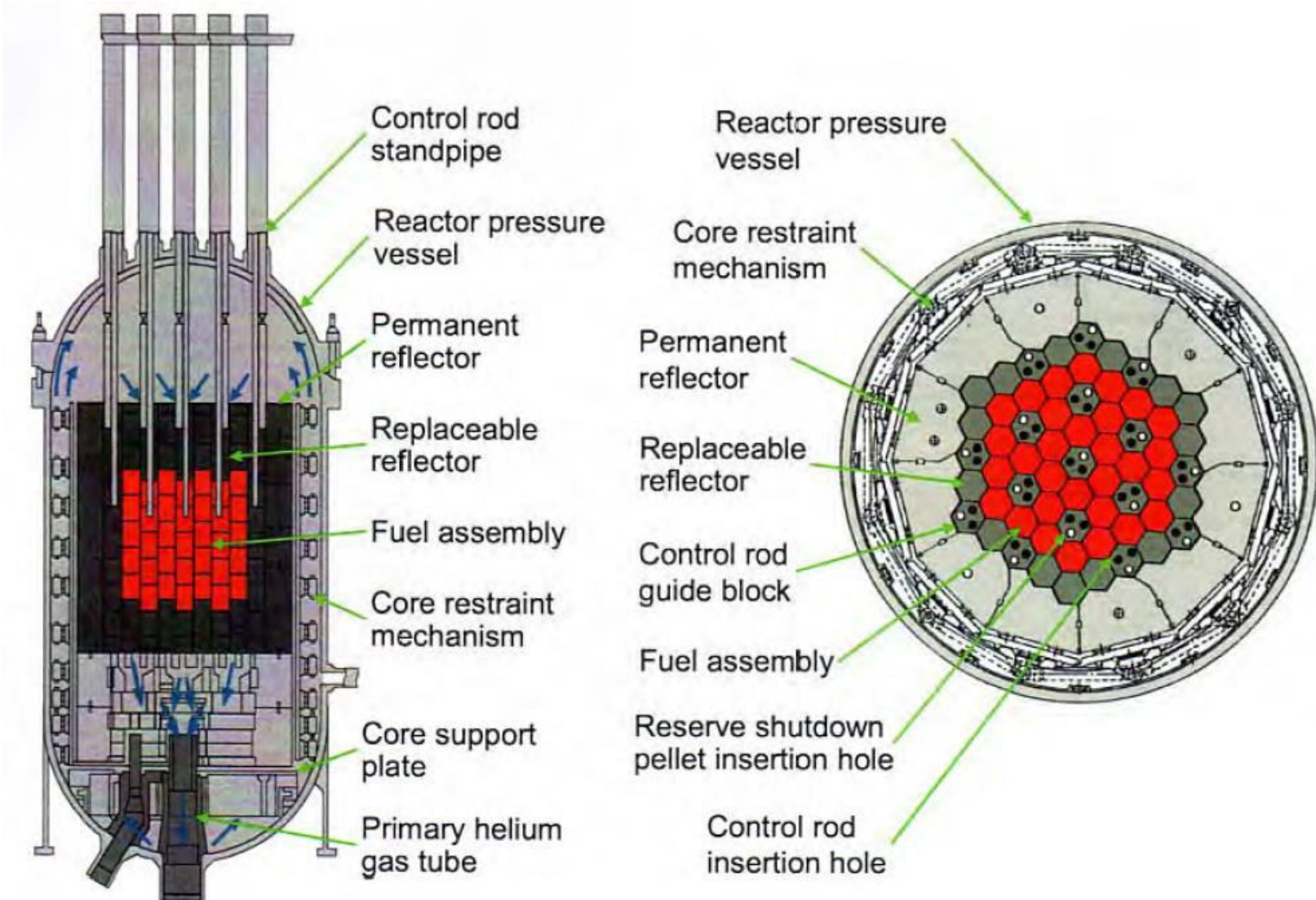

HTR-Module in Germany (Siemens / INTERATOM)

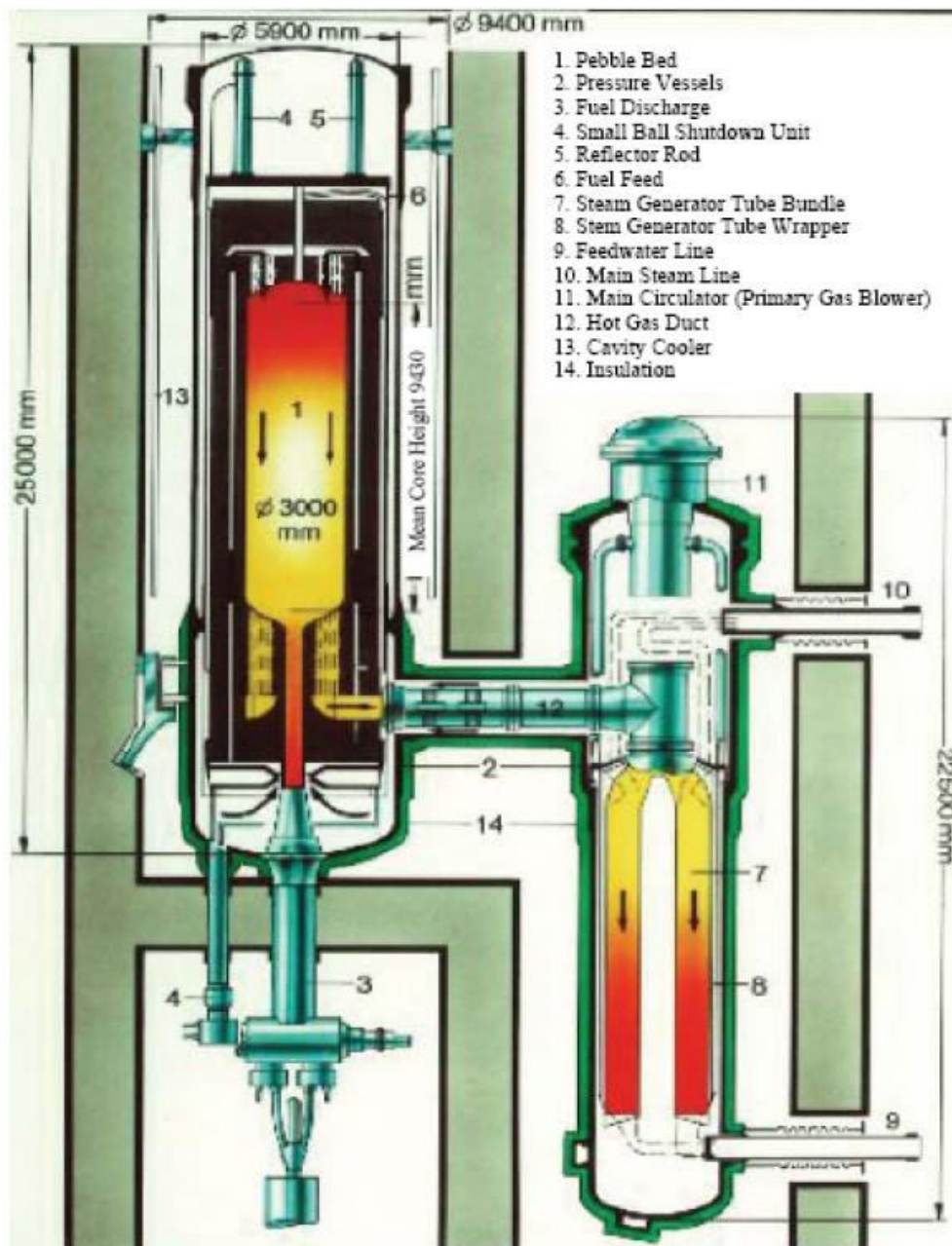

- 200 MW_{th}
- *Bebble bed design*
- *Designed with*
 - *steam generator*
 - *intermediate heat exchanger*
 - *steam reformer*

MHTGR in USA (General Atomic)

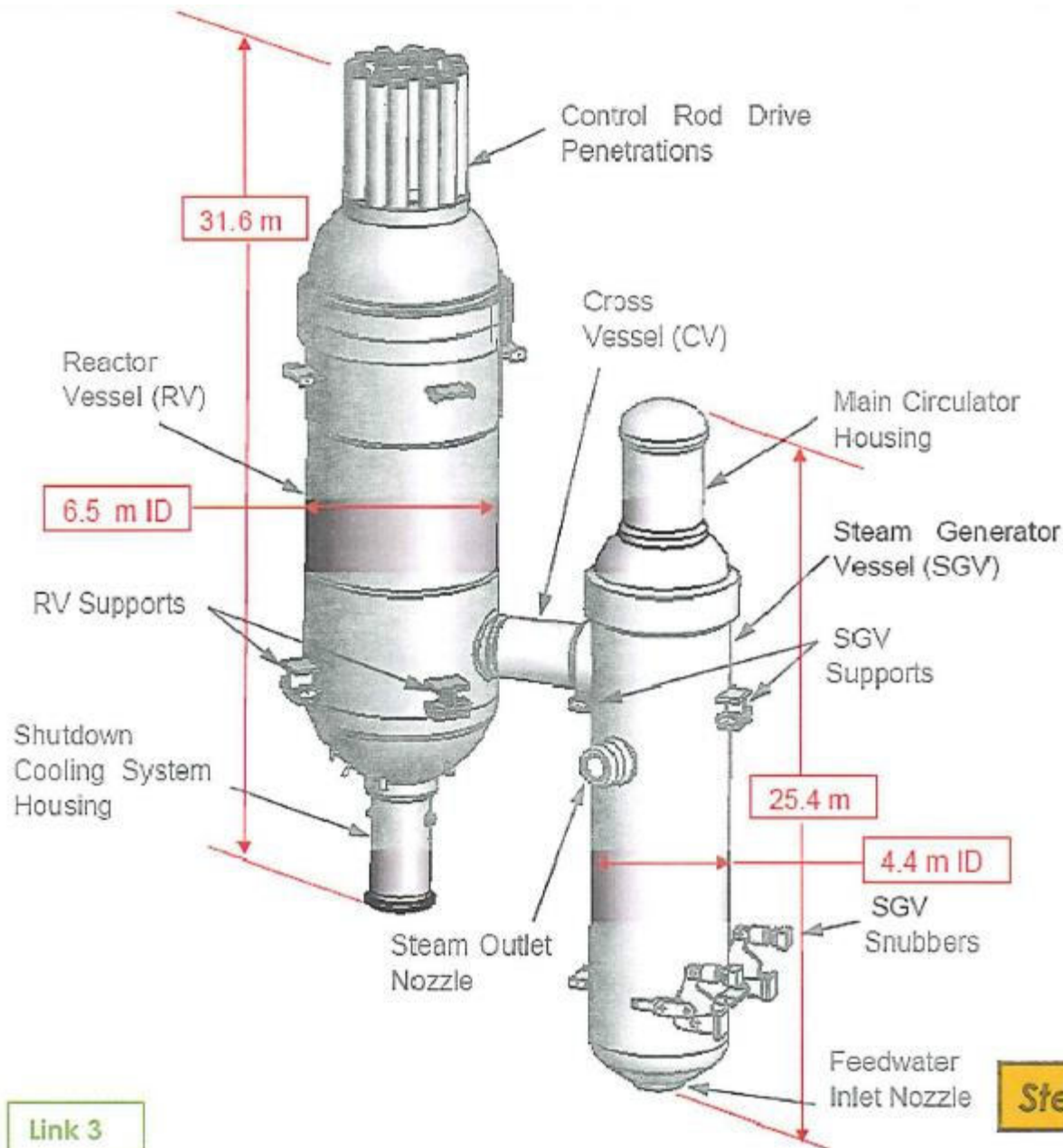

- **350 - 450 MW_{th}**
- **Block design**
- **Designed with steam generator**

Link 3

Reactor Designs / Projects

Pebble Bed Reactors (based on HTR-Module):

<i>PBMR:</i>	<i>FIRST: about 400 MW_{th} , annular core, direct cycle, helium-turbine</i>
	<i>LATE: 250 MW_{th} , one core zone, indirect cycle (steam generator)</i>
<i>HTR 10</i>	<i>10 MW_{th} , one core zone, indirect cycle (steam generator)</i>
<i>HTR-PM:</i>	<i>2 x 250 MW_{th} , one core zone, indirect cycle (steam generator)</i>
<i>NGNP:</i>	<i>Pebble Bed Reactor in analogy to PBMR LATE</i>
<i>RDE</i>	<i>10 MW_{th}, one cone core, indirect cycle</i>
<i>X-Energy</i>	<i>200 MW_{th} , one core zone, indirect cycle (steam generator)</i>

Block Reactors (based on MHTGR):

<i>GTMGR:</i>	<i>600 MW_{th} , annular core, direct cycle, helium turbine</i>
<i>ANTARES:</i>	<i>600 MW_{th} , annular core, indirect cycle, intermediate heat exchanger, gas turbine</i>
<i>NGNP:</i>	<i>Block Reactor in analogy to MHTGR or ANTARES (steam generator)</i>
<i>Korea</i>	<i>Block Reactor, now with 350 MW_{th}, in analogy to MHTGR</i>

SafeG GFR Summer School

Husinec-Rez, Czech Republic, 29.08.-01.09.2022

HTR Systems and Components

Dr. Gerd Brinkmann

**BriVaTech Consulting
Andreas-Sapper-Str. 15
91334 Hemhofen**

phone: +49 9195994747

mail: gerd.brinkmann@gmx.de

Pebble Bed Reactor

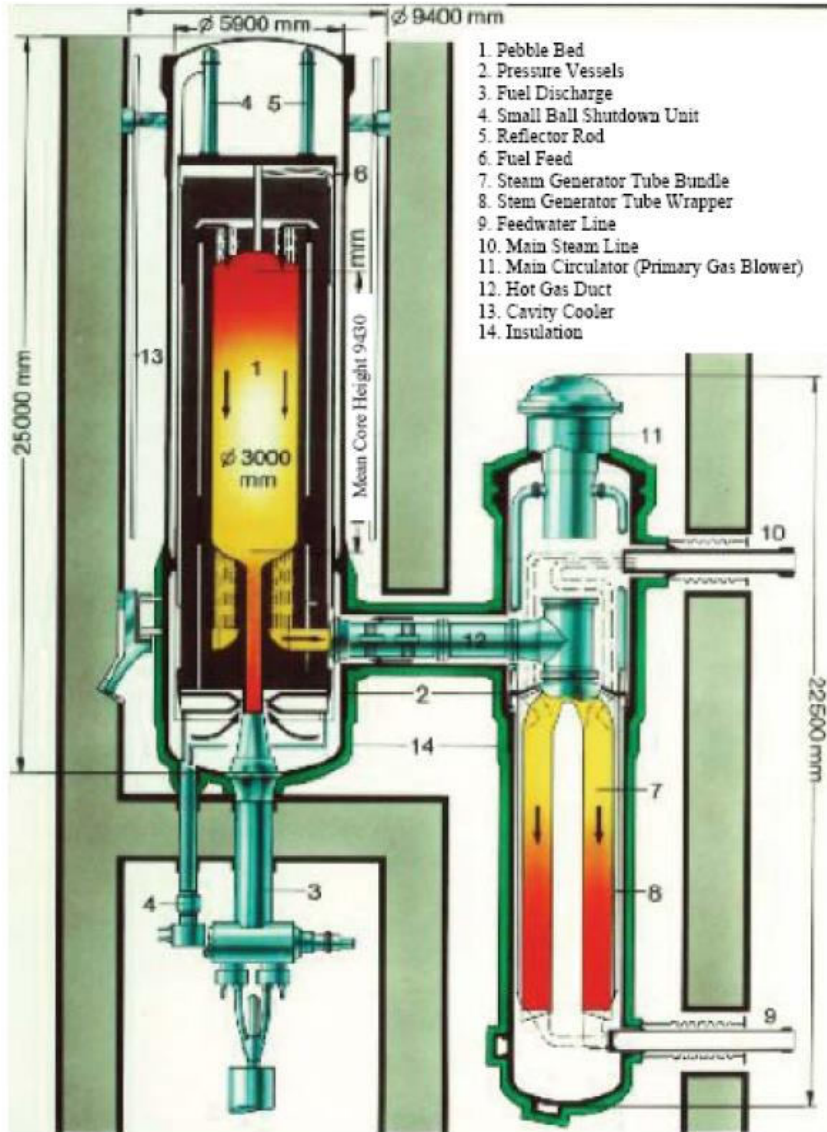

Block Reactor

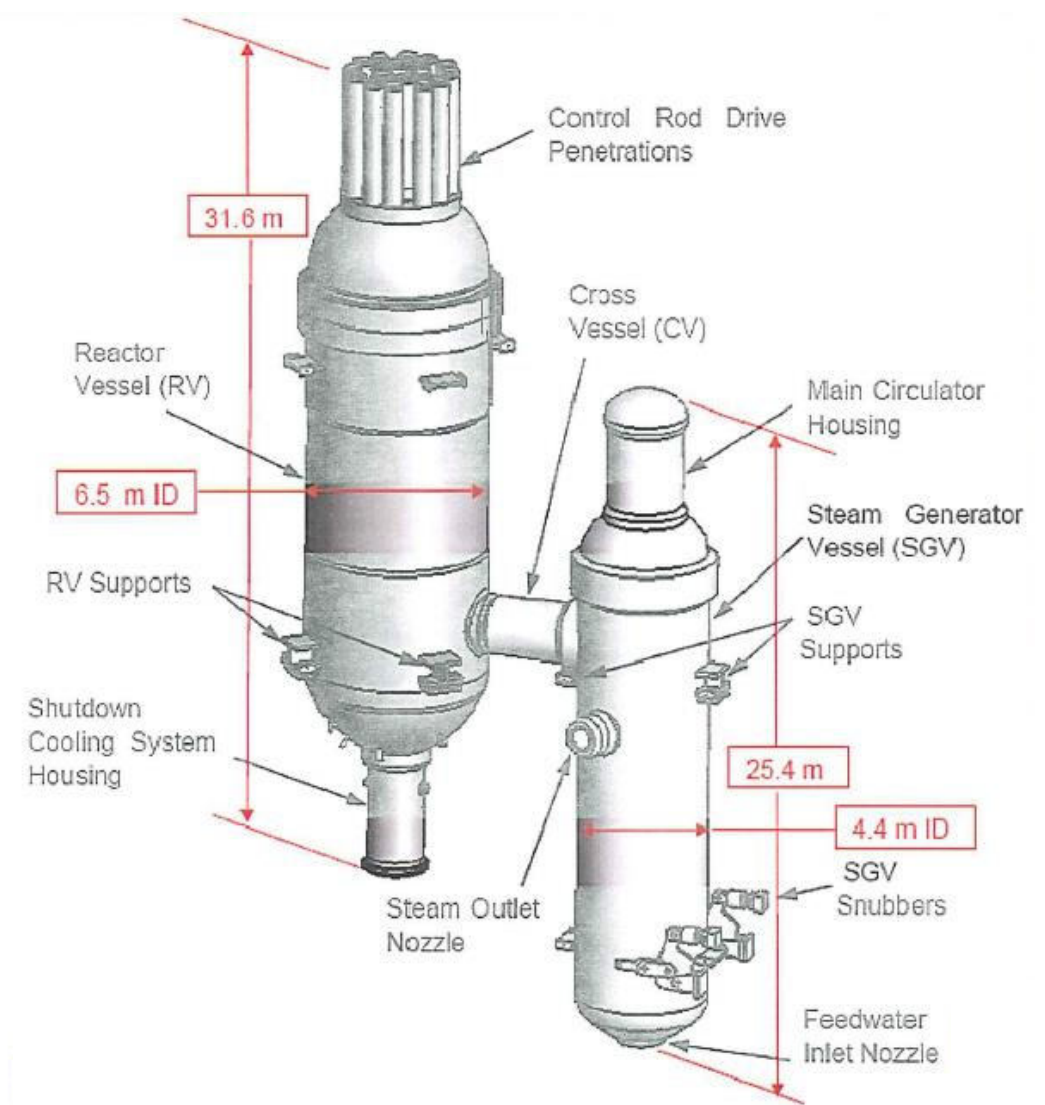

HTR with Steam Generator/IHX

Pebble Bed Reactor and Bock Reactor with SG

Common: RPV, Cross Vessel, SG Vessel
Steam Generator (more or less)
Circulator (more or less)
Rods (more or less)
Cavity Cooling System (more or less)
Helium Auxiliary Systems (more or less)
Hot Gas Duct (more or less)

Different: Fuel Handling Systems
Shut Down Cooling System

Pebble Bed Reactor and Bock Reactor with IHX

IHX and Isolating Valve

Block Diagram He Supporting Systems

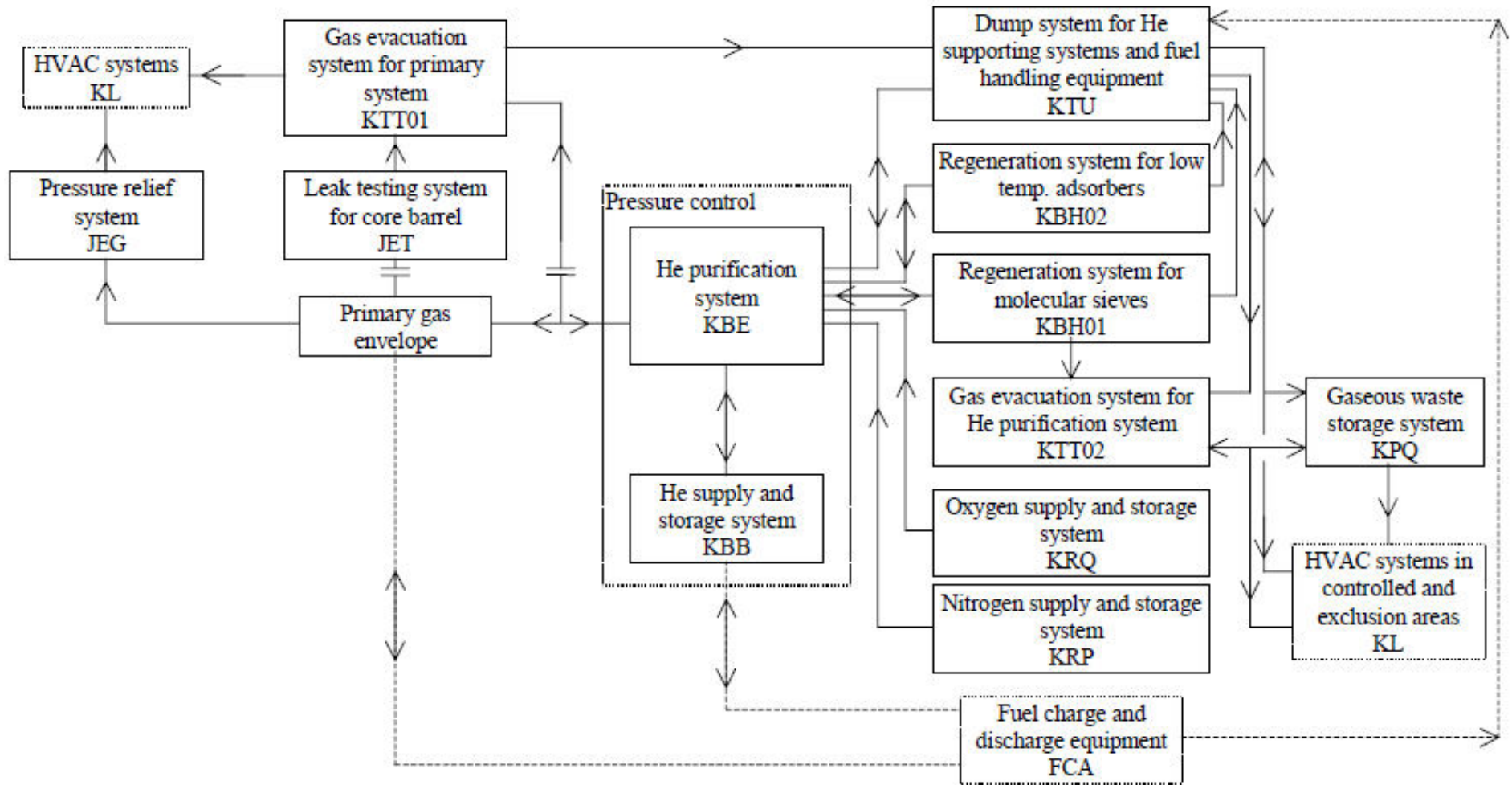

Requirements of Helium Auxiliary Systems(1)

> Operational Requirements:

- * Purification of the primary coolant to remove entrained dustlike and gaseous impurities
- * tritium removal
- * removal of other radioactive impurities (Xe, Kr, Ar)
- * start-up purification of the primary circuits
- * purification of newly delivered helium
- * removal of water after a water ingress accident

> No Safety Requirements

(Systems are necessary only for operation)

Requirements of Helium Auxiliary Systems(2)

Helium Auxiliary Systems are **not safety relevant** (except lines of Hepur up to isolation valves).

- *During normal operation the primary circuit can be operated, depending on the design, for hours or days without reaching limits of values above the stated specification data for the circuit materials.*
- *During DBAs the isolation valves of the Hepur are closed.*

So there can't be no safety relevance. This understanding is in line with the IAEA requirements for HTR.

He-Purification System KBE

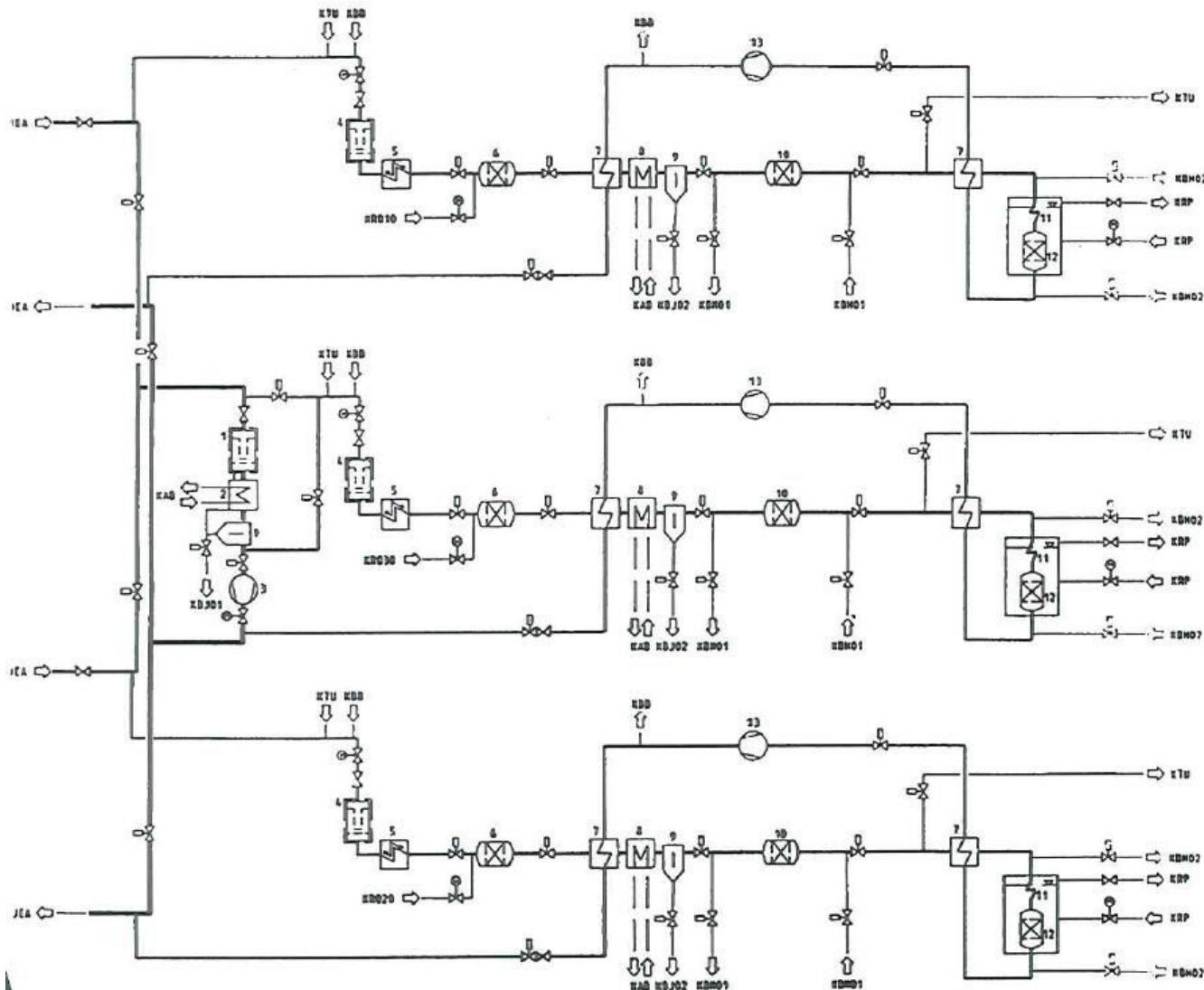

- 1 Commissioning filter
 - 2 Post-accident cooler
 - 3 Post-accident blower
 - 4 Dust removal filter
 - 5 Heater
 - 6 CuO catalytic converter
 - 7 Recuperative heat exchanger
 - 8 Water-to-helium heat exchanger
 - 9 Water separator
 - 10 Molecular sieve
 - 11 Nitrogen-to-helium heat exchanger
 - 12 Activated-carbon absorber
 - 13 Helium blower
-
- JEA Steam generator pressure vessel
 - KAB Operational component cooling system
 - KBB Helium supply and storage system
 - KBHO1 Regeneration system for molecular sieves
 - KBHO2 Regeneration system for low-temperature adsorber
 - KBJO1 Water extraction system for helium supporting system (post-accident)
 - KBJO2 Water extraction system for helium supporting system (normal operation)
 - KRQ10 Oxygen supply and storage system
 - KRQ20 Oxygen supply and storage system
 - KRQ30 Oxygen supply and storage system
 - KRP Nitrogen supply and storage system
 - KTU Dump system for helium supporting systems and fuel handling equipment

Components for retention of impurities

- Dust Removal Filter for Dust
- Copper Oxide Bed for H_2 , CO , CH_4
 - Water Separator for H_2O
- Molecular Sieve for CO_2 , H_2O (Moisture)
- Low Temp. Cooler for residual H_2O , CO_2 , CH_4
- Activated-carbon Adsorber for N_2 , noble gases

Anticipated values for normal operation

- $\text{H}_2\text{O} < 0.1 \text{ vpm}$
- $\text{CO} < 2 \text{ vpm}$
- $\text{N}_2 < 1 \text{ vpm}$
- $\text{H}_2 < 55 \text{ vpm}$
- $\text{CH}_4 < 1 \text{ vpm}$

After accidents

the following short term maximum values can result :

$\text{H}_2\text{O} \sim 3 \text{ vpm}$, $\text{H}_2 \sim 70 \text{ vpm}$, $\text{CO} \sim 100 \text{ vpm}$, $\text{CH}_4 \sim 5 \text{ vpm}$ and $\text{N}_2 \sim 100 \text{ vpm}$

Purified helium returned to the primary circuit $< 0.1 \text{ vpm}$ in general over all impurities

Parameters for design selection:

- Maximum heat loss for the hot gas ducts
- Helium flow rate inside the hot gas ducts
- Geometric dimensions of the pressure vessel
- Maximum differential pressure for the support pipe
- Maximum depressurization rate for the hot gas side
- Maximum temperature variations
- Movements to be compensated in the axial and vertical directions
- Planned inspections
- Concept for disassembling and assembling after start of nuclear operation

Hot Gas Duct: metallic version

Radial layout:

- Liner as a closed metal cylinder
- Depressurization gap for controlled discharge of gas volume from fibrous fill on decompression
- Perforated pipe with mesh cover enclosing the insulant space
- Wrapped fiber mat insulation made of 95% alumina and 5% silica
- Intermediate layer of metal foil to reduce free convection volume
- Wrapped fiber mat insulation made of 95% alumina and 5% silica
- Support pipe housing the internals and serving as pressure boundary between hot and cold gas channels

Axially this arrangement is interrupted approx. every 1000 mm by a vee-shaped spacer. These metallic thermosleeves have the task of supporting the internal flow guides and preventing axial flow through the insulation. The insulant is packed in the region of the vee-shaped spacers. The layout has been qualified by test components with original dimensions in the component testing facility KVK.

Hot Gas Duct: metallic version

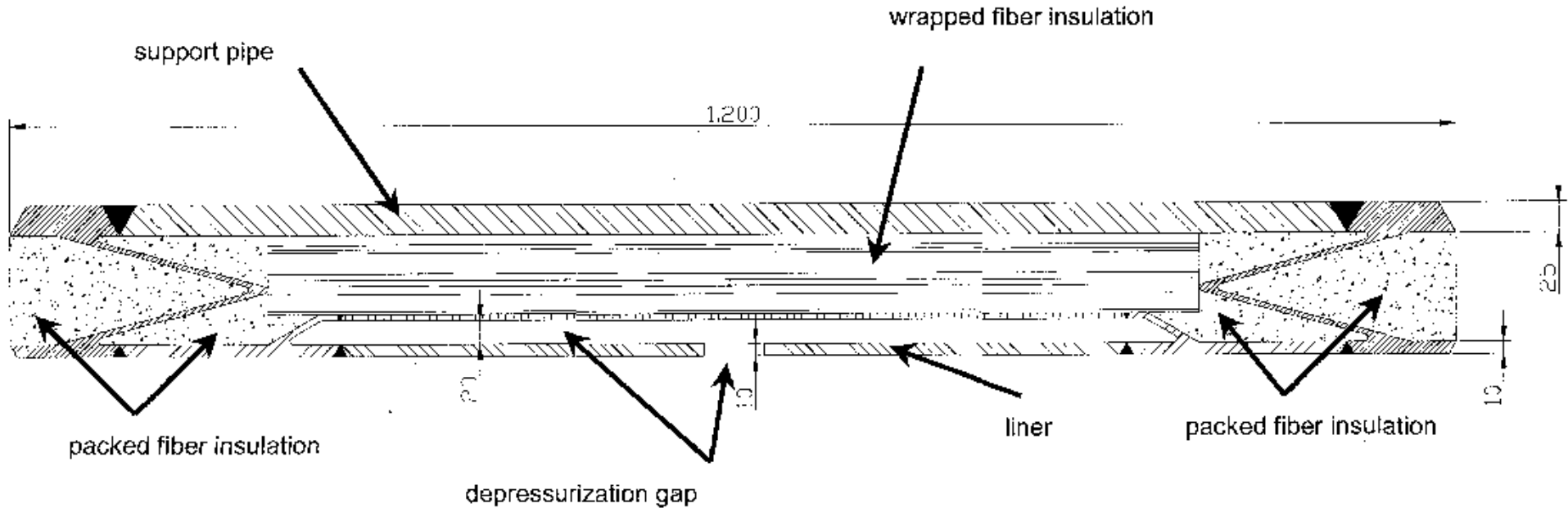

Material Specifications:

Liner, hot side of vee
and depressurization gap tube
Support pipe and cold side of vee
Packed fibre insulation
Wrapped fibre insulation

1.4876 (X10NiCrAlTi32-21 / X10NiCrAlTi32-20)

1.4571 (X6CRNIMOTI17-12-2) with specified cobalt content of maximum 300 ppm
pads made of long fibre mats with 95% Al_2O_3 + 5% SiO_2
fibre-mats made of long fibre with 95% Al_2O_3 + 5% SiO_2

Hot Gas Duct: metallic version

Pictures from manufacturing

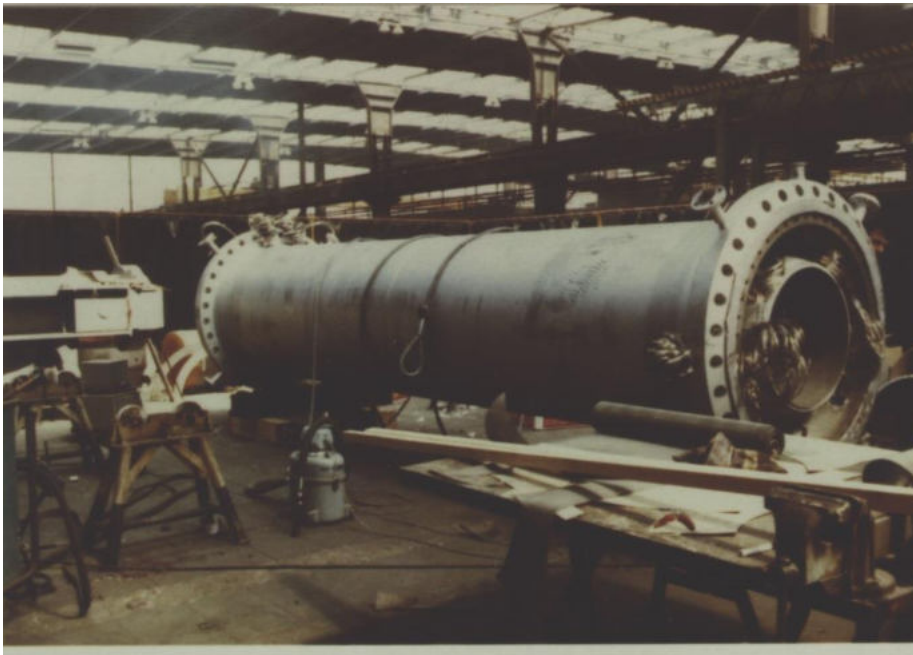

***Horizontal test tube
outer diameter 1220 mm
wall thickness 30 mm
flow diameter 700 mm***

***90° elbow test tube
outer diameter 1320 mm
wall thickness 50 mm
flow diameter 700 mm***



Hot Gas Duct: ceramic version

Radial layout :

- Liner as a closed graphite or cfc cylinder
- No depressurization gap because the liner can withstand about 90 bar differential pressure
- Wrapped fiber mat insulation made of 95% alumina and 5% silica
- Intermediate layer of graphite foil to reduce free convection volume and axial flow through the insulation
- Wrapped fiber mat insulation made of 95% alumina and 5% silica
- Support pipe housing the internals and serving as pressure boundary between hot and cold gas channels

Axially this arrangement is interrupted approx. every 1000 mm of maximum liner-tube length. Because there are no thermosleeves to preventing axial flow through the insulation such as are used in the metallic version, several graphite foils (approx. every 10 mm) in the insulation provide a large pressure drop in the axial direction. The insulant is packed in the region of the ceramic spacers. The layout has been qualified by test components with original dimensions in the test facility KVK

Hot Gas Duct: ceramic version

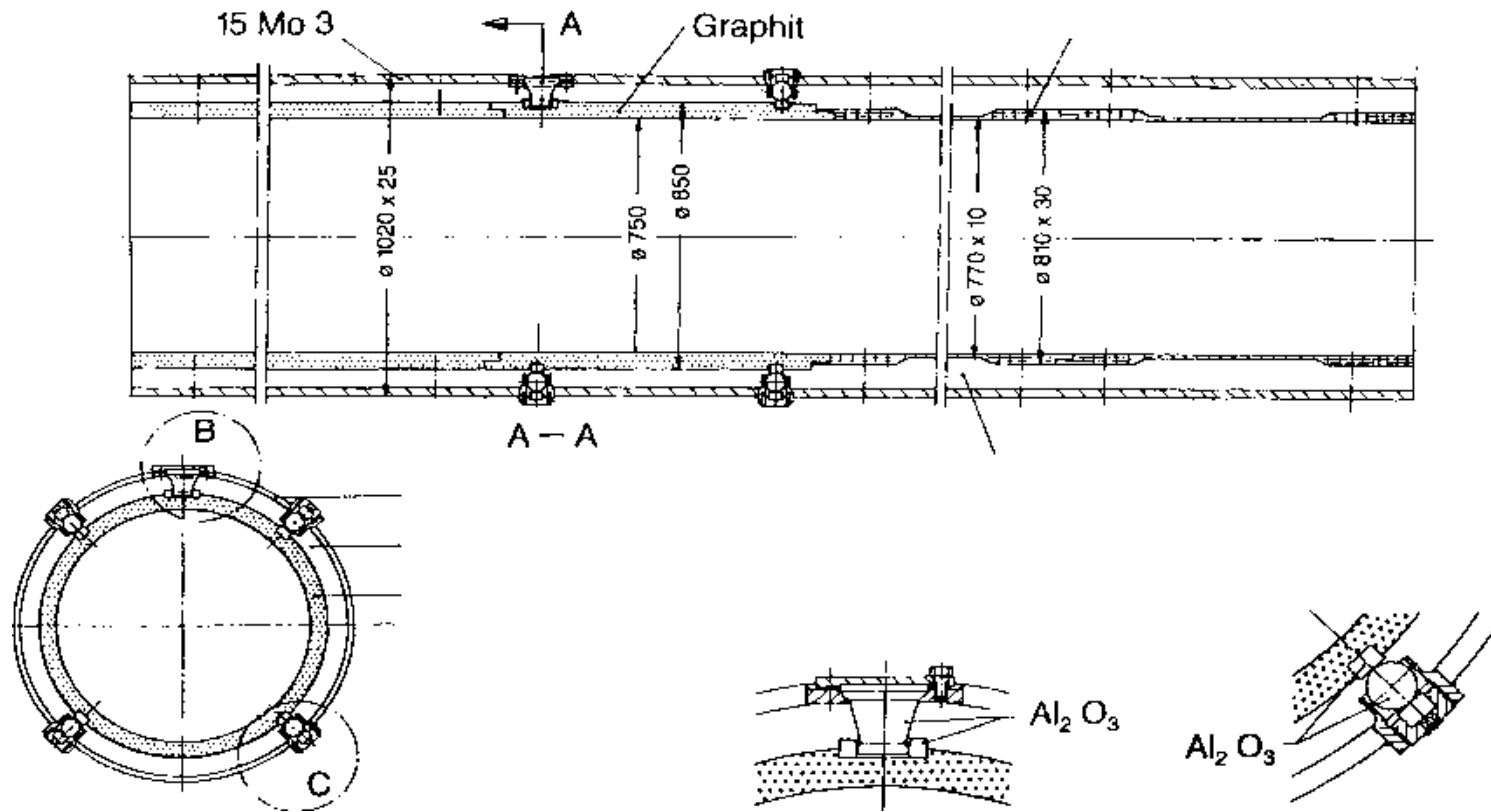

Material Specifications:

Liner
Radial and axial ceramic spacers

Packed fibre insulation
Wrapped fibre insulation
Support pipe

Graphite type ASR-1RG, carbon fibre composite (CFC)
 Al_2O_3 ceramic, under pressure from all sides

pads made of long fibre mats with 95% Al_2O_3 + 5% SiO_2
fibre-mats made of long fibre with 95% Al_2O_3 + 5% SiO_2
1.4571 (X6CrNiMoTi17-12-2) with specified cobalt content
of maximum 300 ppm

Hot Gas Duct: ceramic version

Pictures from manufacturing



***Horizontal test tube
outer diameter 1020 mm
wall thickness 20 mm
flow diameter 700 mm***

***Core Connection
System test tube
flow diameter 700 mm***



Cavity Cooling System

Function

- *Protection of the Reactor Cavity Concrete Structure from overheating*
- *To protect the reactor cavity concrete structure from overheating during all modes of operation.*

Decay Heat Removal

To provide an alternate means of reactor core heat removal from the Primary Circuit to the environment when neither the Main Heat Transport System nor the Shutdown Cooling Helium System JED (SCS)/Shutdown Cooling Water System KAE is available.(SCS only in block type reactors)

Accordingly, the Secured Component Cooling System KAA decay heat removal function ensures safety protection. Since the KAA is expected to be relied upon to meet safety criteria, the components of the system are classified as "safety-related". To fulfil these safety-related function the Secured Component Cooling System KAA has a system structure with two independent cooling trains, each of them being able to reject 100% of the maximum thermal load, which it is exposed to, depending on the reactor operating mode.

Active Cavity Cooling System (Water)

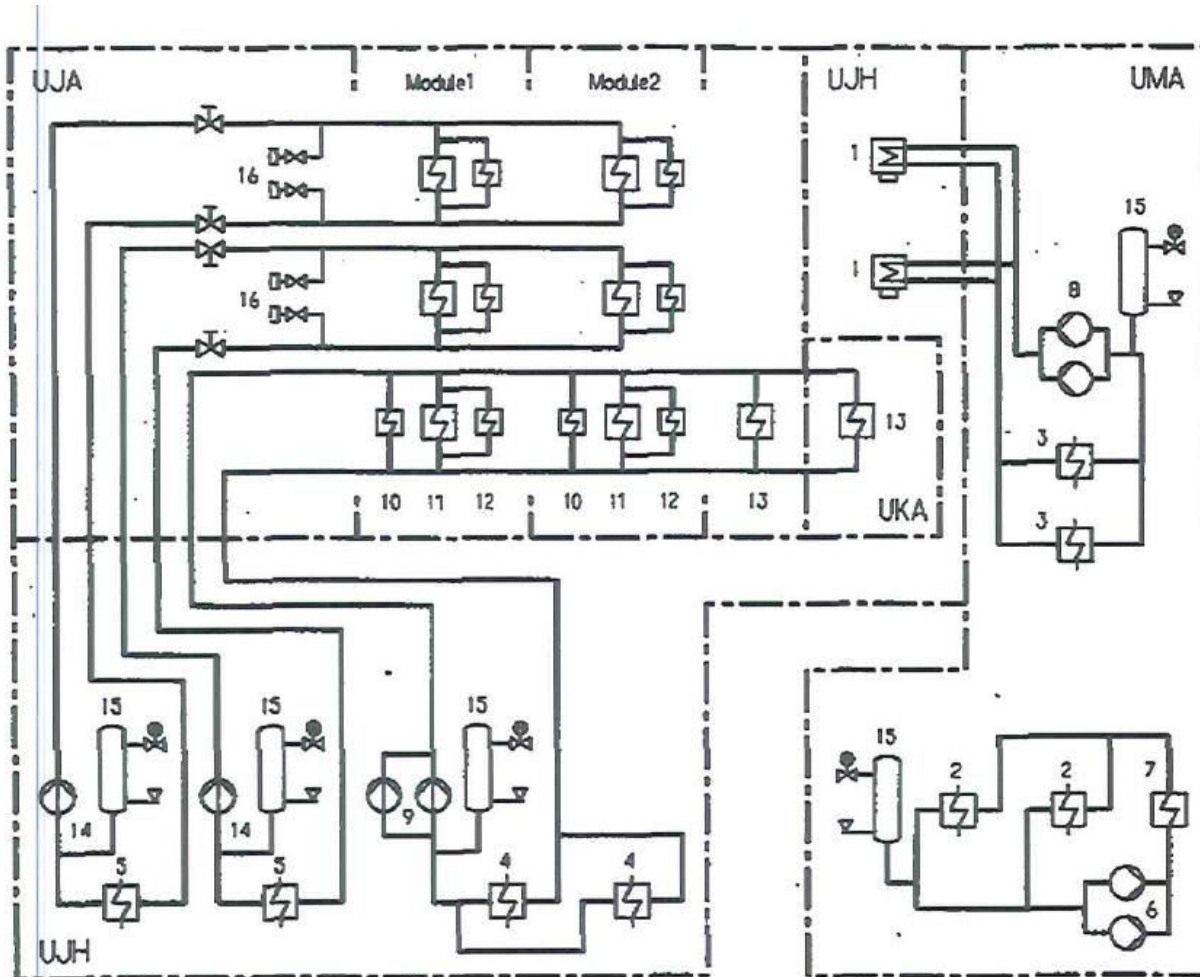

- 1 Condenser/coolers
- 2 Conventional closed cooling water system heat exchangers
- 3 Closed cooling water system heat exchangers for start-up and shutdown circuits
- 4 Operational component cooling system heat exchangers
- 5 Secured cooling system heat exchangers
- 6 Conventional closed cooling water pumps
- 7 Conventional closed cooling water loads
- 8 Component cooling pumps for start-up and shutdown circuits
- 9 Operational component cooling pumps
- 10 Primary gas blower
- 11 Cavity cooler
- 12 Supports for pressure vessel unit and nozzles on RPV bottom head (fuel discharge tube)
- 13 Operational component cooling water loads
- 14 Secured cooling pumps
- 15 Surge tank
- 16 Fire brigade connections

UJA Reactor building
 UJH Reactor building annex
 UKA Reactor auxiliary building
 UMA Turbine building

Active Cavity Cooling System (Water)

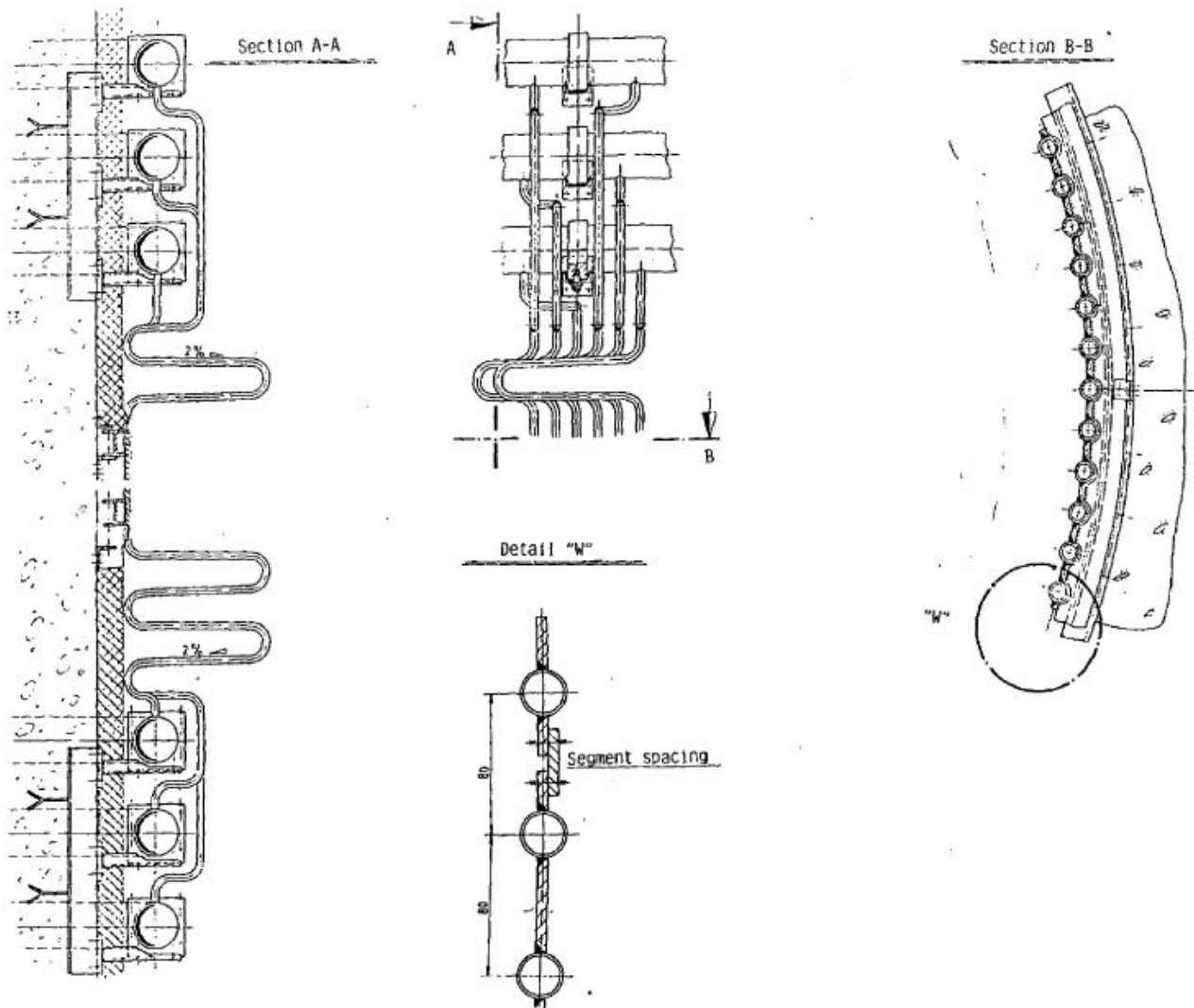

Passive Cavity Cooling System (Water)

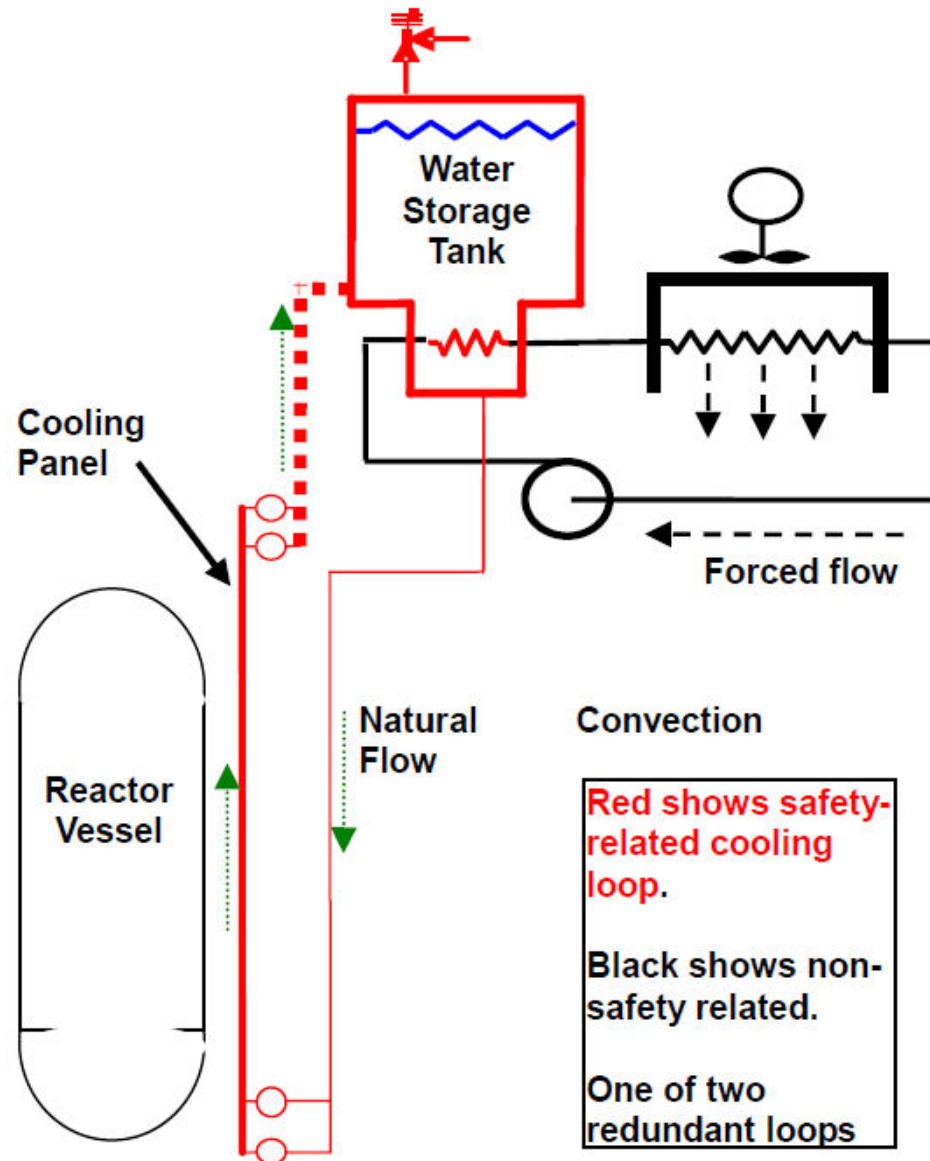

US design, earthquake not a DBA. Otherwise the recooling system becomes safety related

Passive Cavity Cooling System (Air)

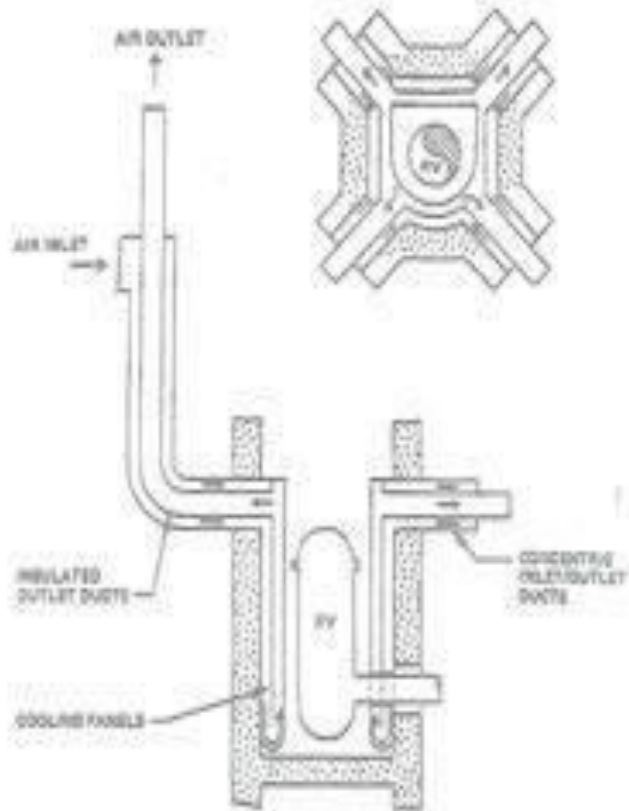

- The RCCS transfers heat from the Reactor Vessel to the atmosphere during:
 - Normal operation
 - Loss of Forced Circulation
- Heat transfer - natural convection in tubes containing outside air
- Heat is transferred from reactor vessel side wall to the RCCS cooling panels mostly by radiation
- Reactor vessel side walls not insulated to provide a passive decay heat removal path to atmosphere
- Reactor silo concrete maintained at acceptable temperatures during normal operation & LOFC CCDs

Fuel Handling Equipment for Pebble Bed Reactors

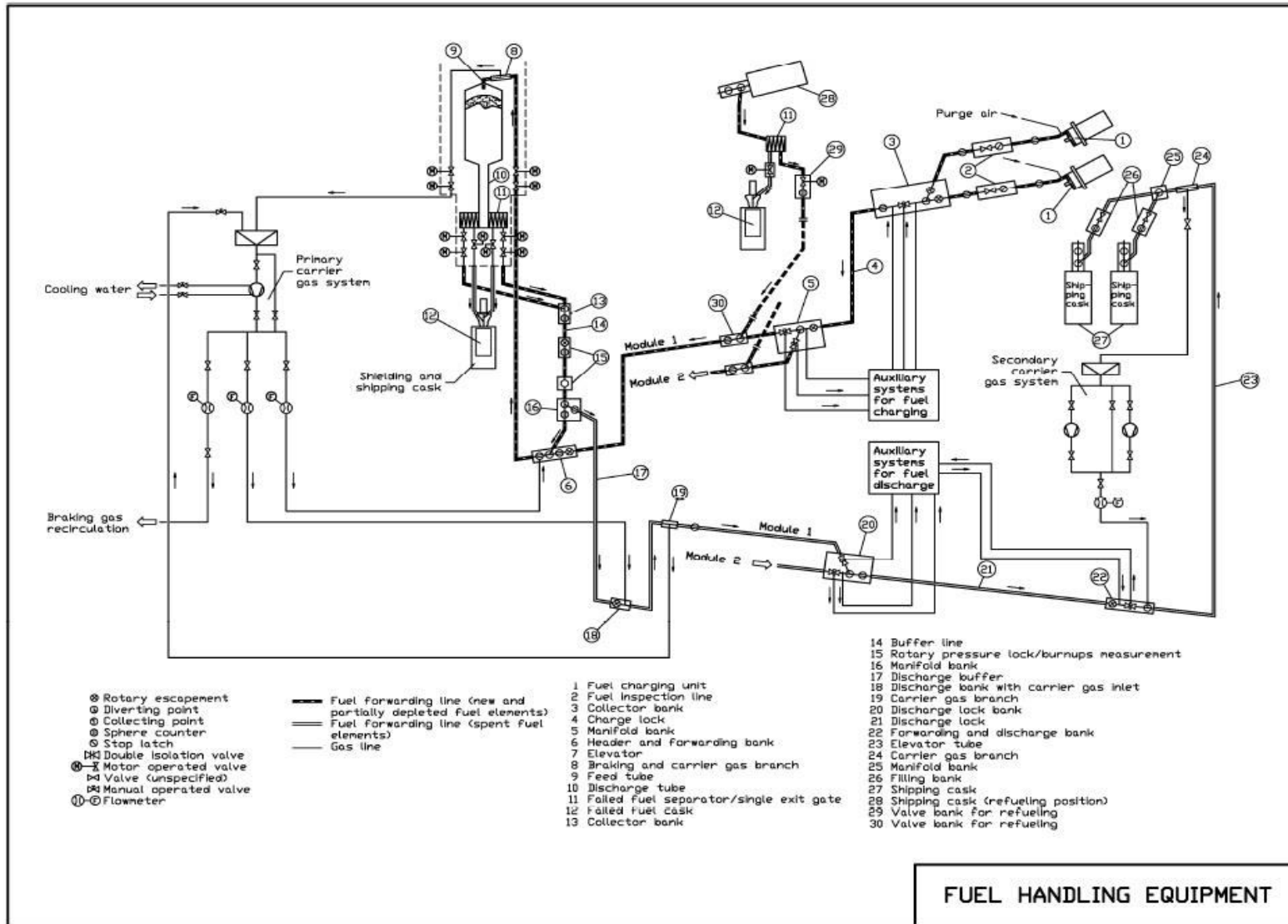

Fuel Handling Equipment for Pebble Bed Reactors



Test facility of core discharging device



On-site test of outside fuel counter

Fuel Handling Equipment for Block Reactors

- Specialized fuel handling machinery includes:
 - Fuel handling machine
 - Fuel transfer cask
 - Fuel handling equipment positioner
- Fuel removed and replaced using robotic manipulators that enter the reactor vessel through neutron control penetrations
- Half of reactor core is refueled every 18-20 months
- Fuel residence time in core is 3 years
- Surface dose rate from an irradiated fuel element $\sim 10^7$ R/hr, requiring substantial shielding
- Initial heat rate ~ 1540 W/ block (3-day)
- Out-of-pool heat rate ~ 626 W/ block (100-day)

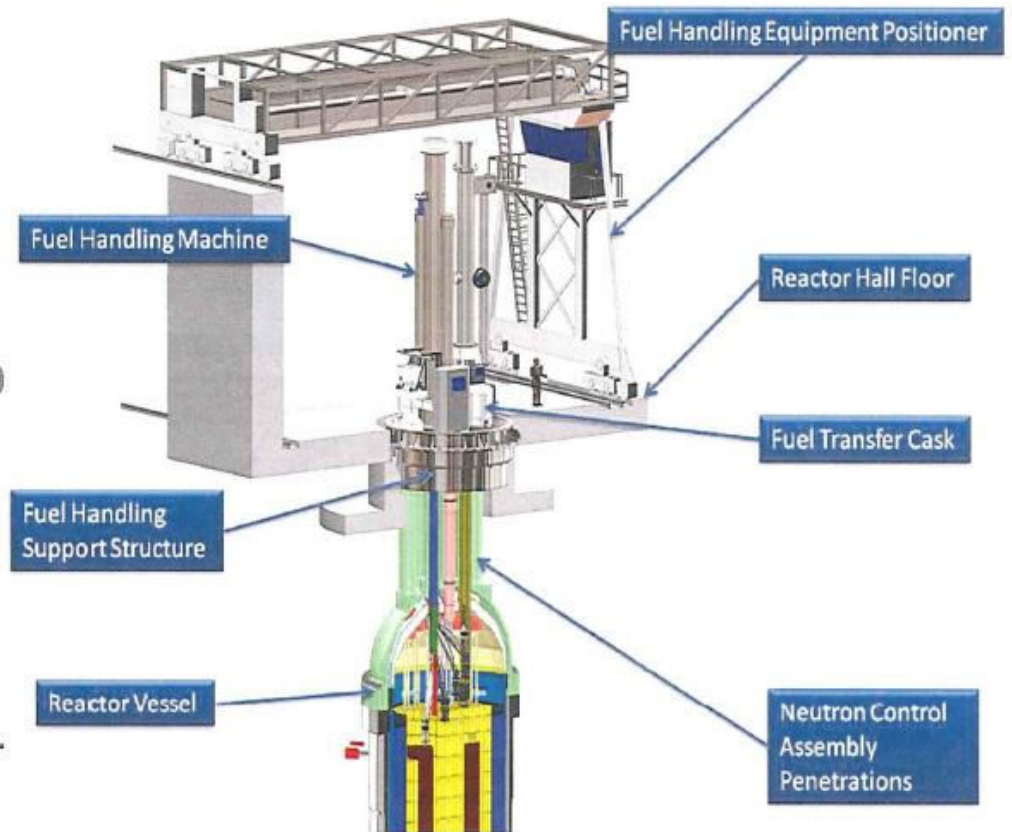

Fuel Handling Equipment for Block Reactors

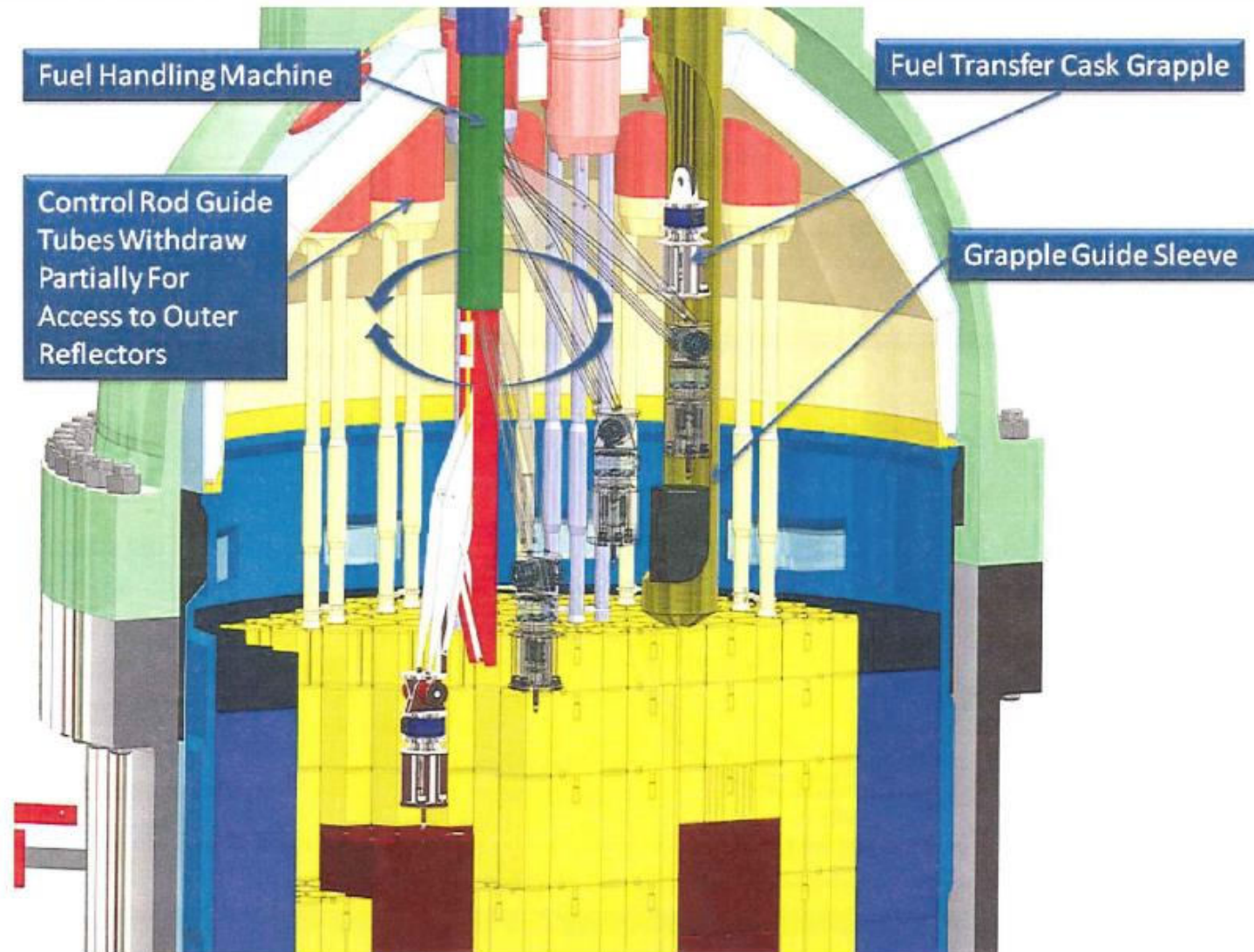

Intermediate Heat Exchanger (IHX)

- 1 Pressure boundary
- 2 Outer liner
- 3 Outer insulation
- 4 Primary cold gas gap
- 5 Tube spacer system
- 6 Support system
- 7 Inner secondary tube
- 8 Insulation of inner secondary tube
- 9 Core
- 10 Cavity cooler
- 11 Tube bundle (helix)
- 12 Blower
- 13 Primary hot gas duct
- 14 Secondary loop

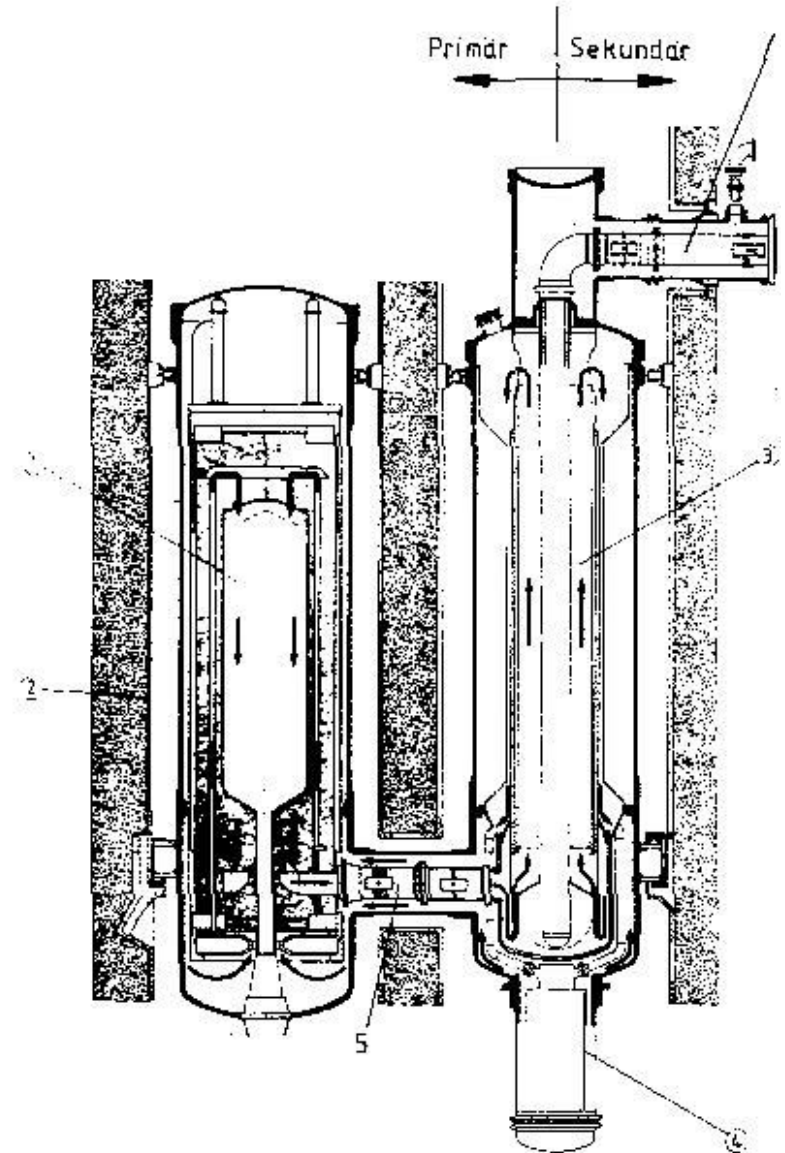
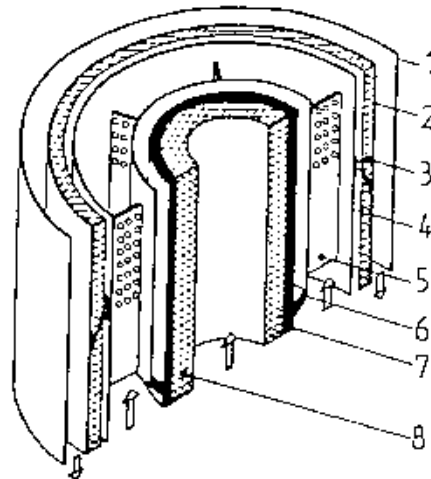

Test Facility KVK



<i>Thermal power</i>	10 MW
<i>He-temperature</i>	950 °C
<i>Operating-pressure</i>	40 bar
<i>He-flow</i>	3 kg/s
<i>He-velocity</i>	60 m/s
<i>Temperature transients</i>	± 200 K/min
<i>Pressure-transient</i>	- 5 bar/s

<i>Operation time:</i>	
> 900 °C	~ 7.000 h
> 700 °C	~ 12.000 h

Test Facility KVK, flow sheet with test positions

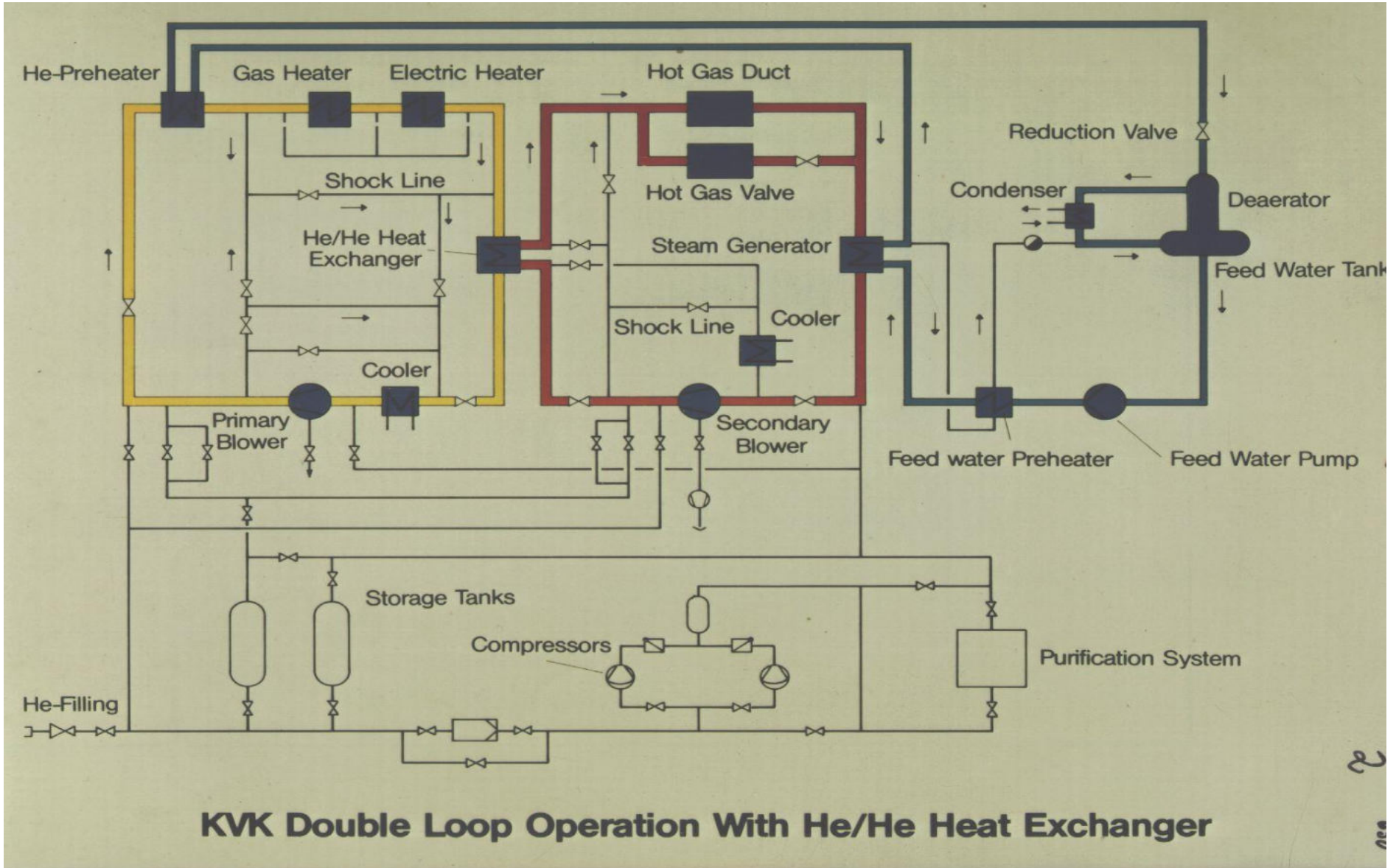

Intermediate Heat Exchanger (IHX)

The helium gas intermediate heat exchanger is subject to a maximum helium inlet temperature of 950°C on the primary side and 900°C on the secondary side. The differential pressure across the tube wall in operation is approx. 2 bar; the secondary-side pressure is maintained above that on the primary side to prevent leakage of contaminated helium.

Only during a sudden loss of secondary-side pressure accident could the tube wall be exposed to full primary-side pressure for a brief period of time.

The helical tube heat exchanger is to be kept as compact as possible and should have an economical design lifetime of 10^5 h. The following data are possible:

<i>Thermal duty</i>	<i>170 MW</i>
<i>Number of tubes</i>	<i>2000</i>
<i>Tube dimensions</i>	<i>22 mm x 2 mm</i>
<i>Tube length</i>	<i>100 m</i>
<i>Bundle length</i>	<i>17,700 mm</i>
<i>Bundle diameter</i>	<i>3,000 mm</i>

Intermediate Heat Exchanger (IHX)

Flow through the helical tube heat exchanger is with primary gas passing through the exterior of the tube bundle and secondary gas passing through the helically wound tubes. The tubes are held by the upper tubesheet which also forms the channel head for the cold secondary helium. A central return channel (in principle a vertical hot gas pipe) is shaped at the bottom like a header (hot gas header). All heat exchanger tubes are welded into this header. Support stars which provide variable tube guidance are arranged at several vertical levels within the tube bundle. The primary hot helium passes from below into the component and exits at a relatively low temperature (approx. 300°C) between the pressure vessel and an inner gas guide and is returned to the blower.

This compact design permits heat fluxes of about 50 kW/m². The maximum tube wall temperature is approx. 920°C and therefore material IN 617 can be used for the hot piping and also for the header.

A prototype heat exchanger with a thermal duty of 10 MW was constructed and tested at the KVK test rig; the hot gas header was modeled full scale, i.e. for 170 MW.

Intermediate Heat Exchanger (IHX)

Helix type, pictures from manufacturing

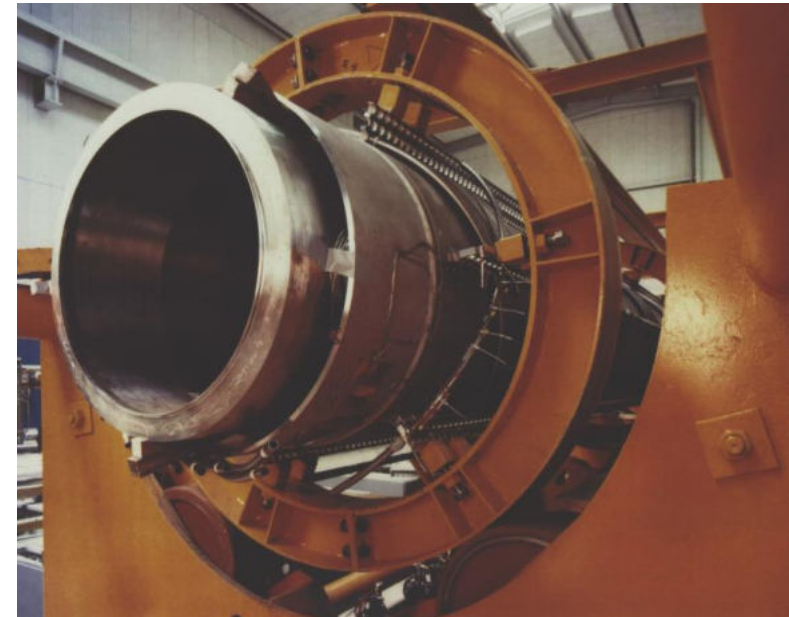
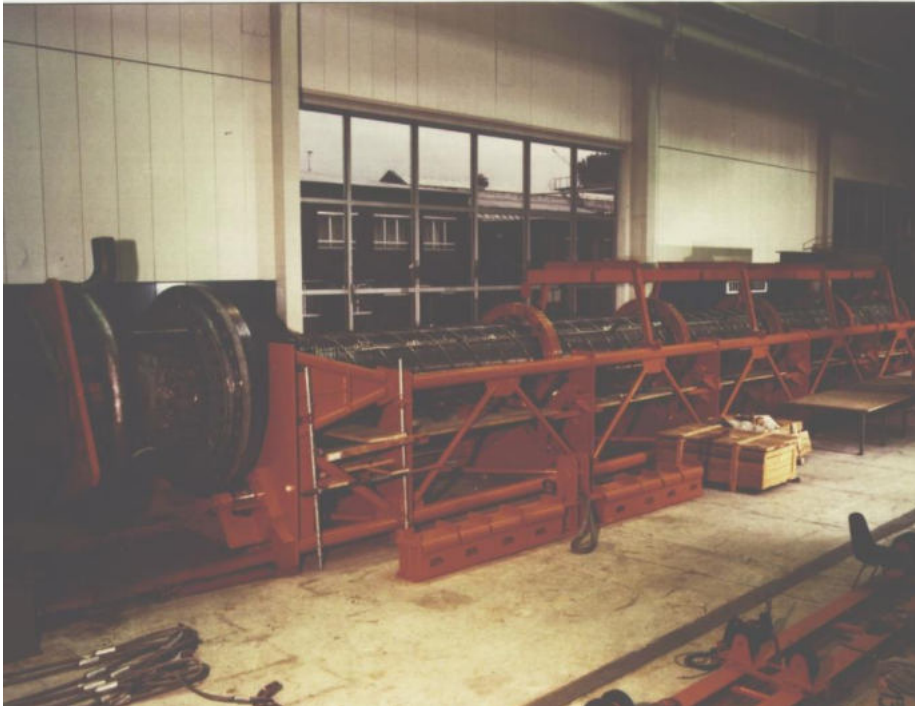

Isolation Valves (secondary side)

In indirect-cycle units the nuclear-generated heat is extracted from the coolant by a gas-filled secondary cycle comprising plant equipment which is independent from the reactor plant (e.g. intermediate heat exchanger). For this purpose the secondary gas must be forwarded from the reactor system to the connected heat sink through an internally insulated pipe and returned by way of an externally insulated pipe.

In the case of the larger-diameter secondary-side piping both the cold-leg and the hot-leg piping have to be run within the reactor plant to the intermediate heat exchanger. As a result of this configuration the requirement exists that isolation of this piping must be possible in the area of the confinement penetrations so as to ensure safe confinement of radioactivity.

The valves needed for the cold-leg piping (approx. 350°C) are not discussed as these are essentially conventional items. However, no commercially available valves are capable of fulfilling the specific requirements applicable to the hot-leg valves. For this reason the axial valve adopted as preference by Siemens in the course of HTR Module development.

Isolation Valves (secondary side)

Design Features of RCS Isolation Valves

In the course of the above-mentioned development project the following main design data and operating data were established for the secondary-side hot gas valves. Most of these specifications can be applied unchanged to new projects:

Operating pressure	41.9 bar
Hot gas temperature	900 ±18°C
Body design temperature (pressure boundary)	400°C
Helium mass flow	47.3 kg / s
Temperature transient (startup and shutdown)	± 2 K / min
Total closing time	≤ 5 s
Max. Δp across seat	42 bar
Max. Δp during opening and closing	3.5 bar (maximum backpressure to be overcome)
Leakage rate from both seats	1 mbar·l / s (cf. Section 3.5)
Design lifetime	140,000 h
Prototype dimensions:	
Pressure-retaining pipe	Dia. 1,120 mm, t = 30 mm
Free flow cross section	Dia. 700 mm
Total length	2,400 mm

Isolation Valves (secondary side)

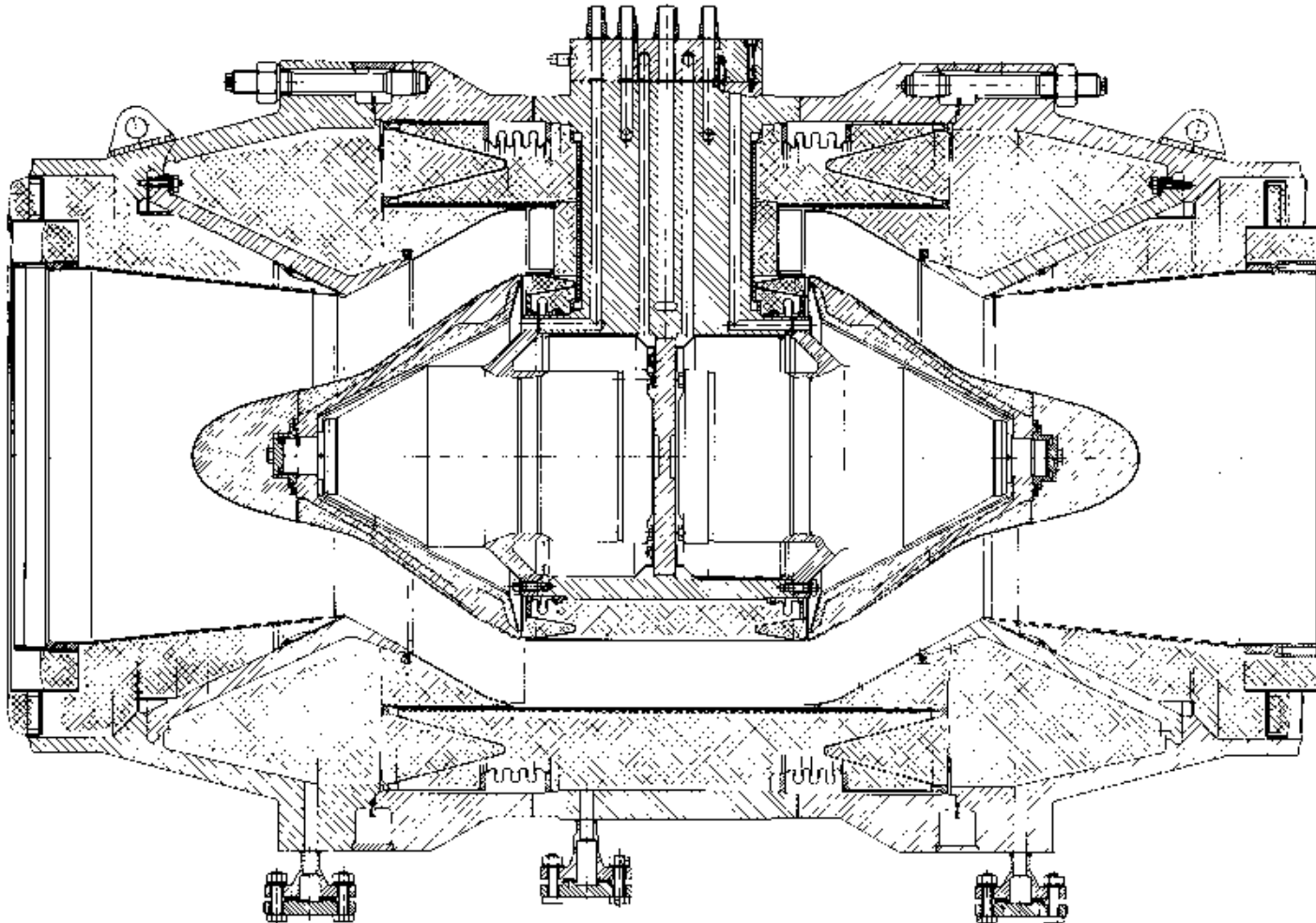

Isolation Valves (secondary side)

**Axial valve type,
pictures from
manufacturing**



SafeG GFR Summer School

Husinec-Rez, Czech Republic, 29.08.-01.09.2022

**Safety Analysis
of
High Temperature Gas Cooled Reactors**

Dr. Gerd Brinkmann

BriVaTech Consulting

Andreas-Sapper-Str. 15

91334 Hemhofen

phone: +49 9195994747

mail: gerd.brinkmann@gmx.de

High Temperature Gas Cooled Reactors

Modern HTGRs:

Coolant: Helium (inert noble gas, no heat transfer or phase change, very little effect of density on reactivity)

Moderator: Graphite

Reflector: Graphite (high heat capacity)

Fuel: Coated Particles (low failure fraction during normal and accident conditions)

No Core Melt

HTGR Development

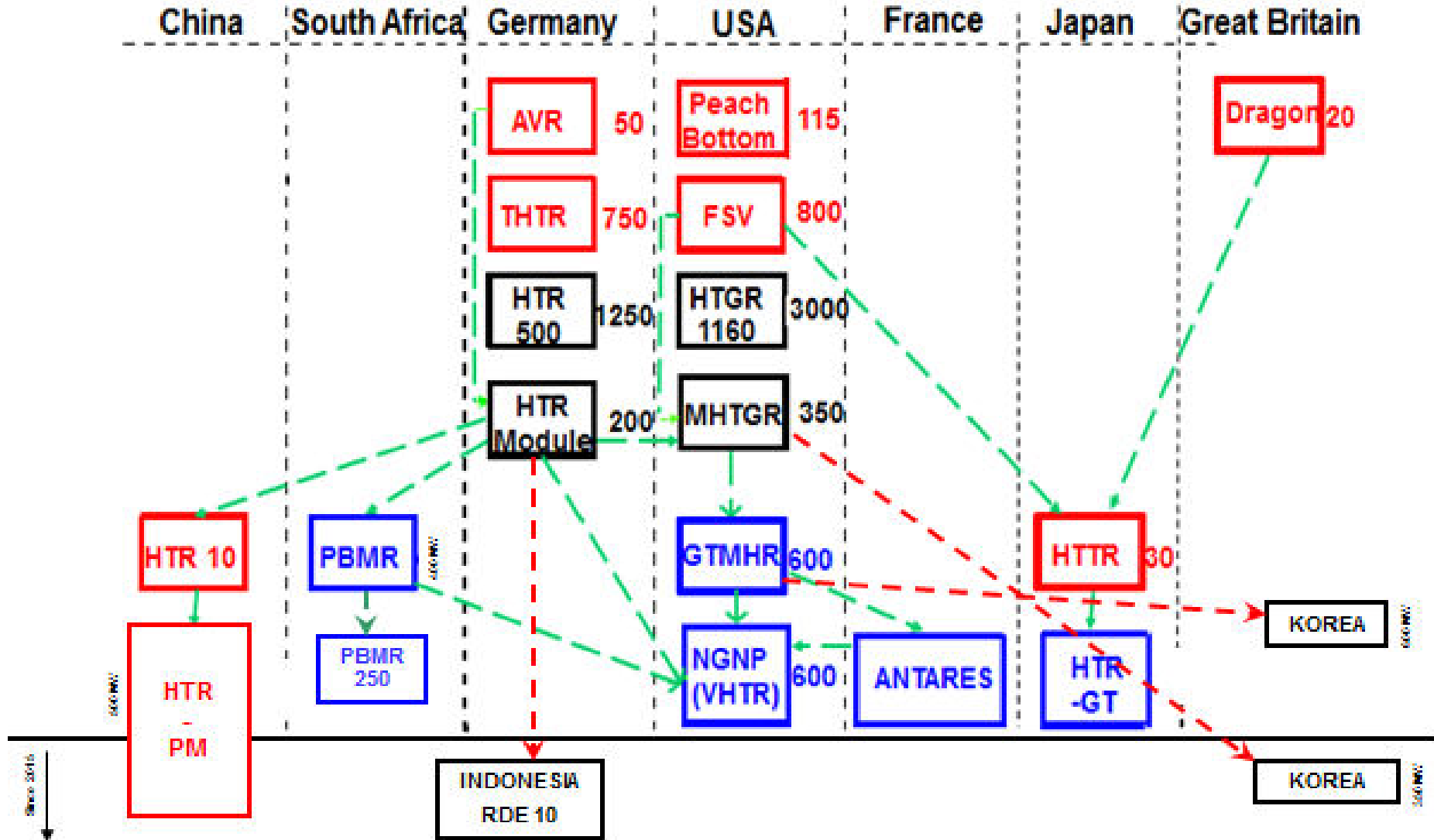

Modular HTGRs

means several of „small“ reactors instead of one „big“

What is the **advantage** based on the great goals of nuclear power plants?

Radioactive Release: low due to low fuel temperature

Shutdown: low safety demands on shutdown systems due to the high negative temperature coefficient

Decay Heat Removal: passive systems outside of the reactor vessel, mainly for the structures and not for the fuel temperature

Radioactive Release

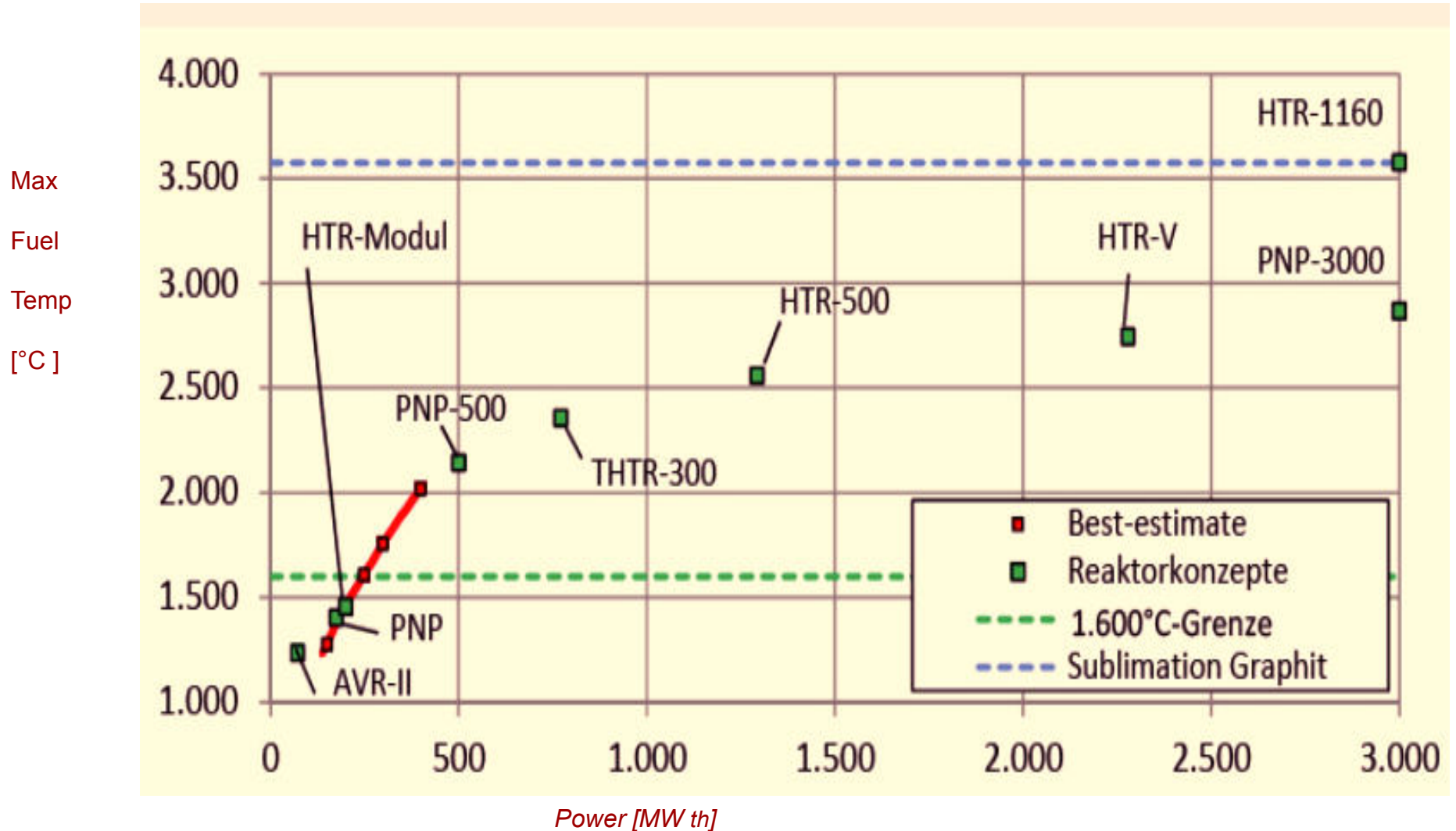

Radioactive Release

FRACTIONAL FISSION PRODUCT RELEASE OF COATED PARTICLES VS. TIME AND TEMPERATURE

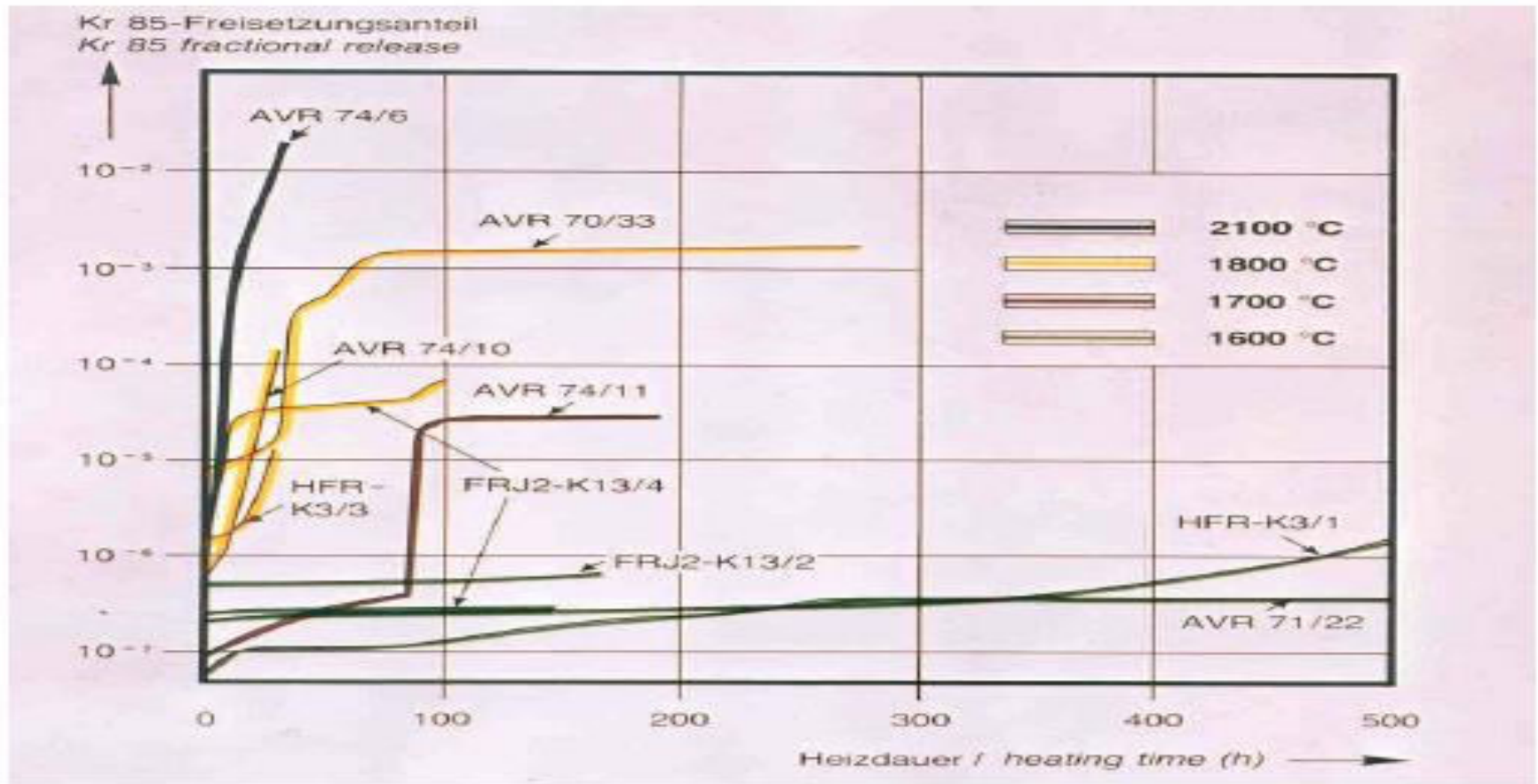

HTR-10: Reactor SCRAM without rods EXPERIMENT in 2004

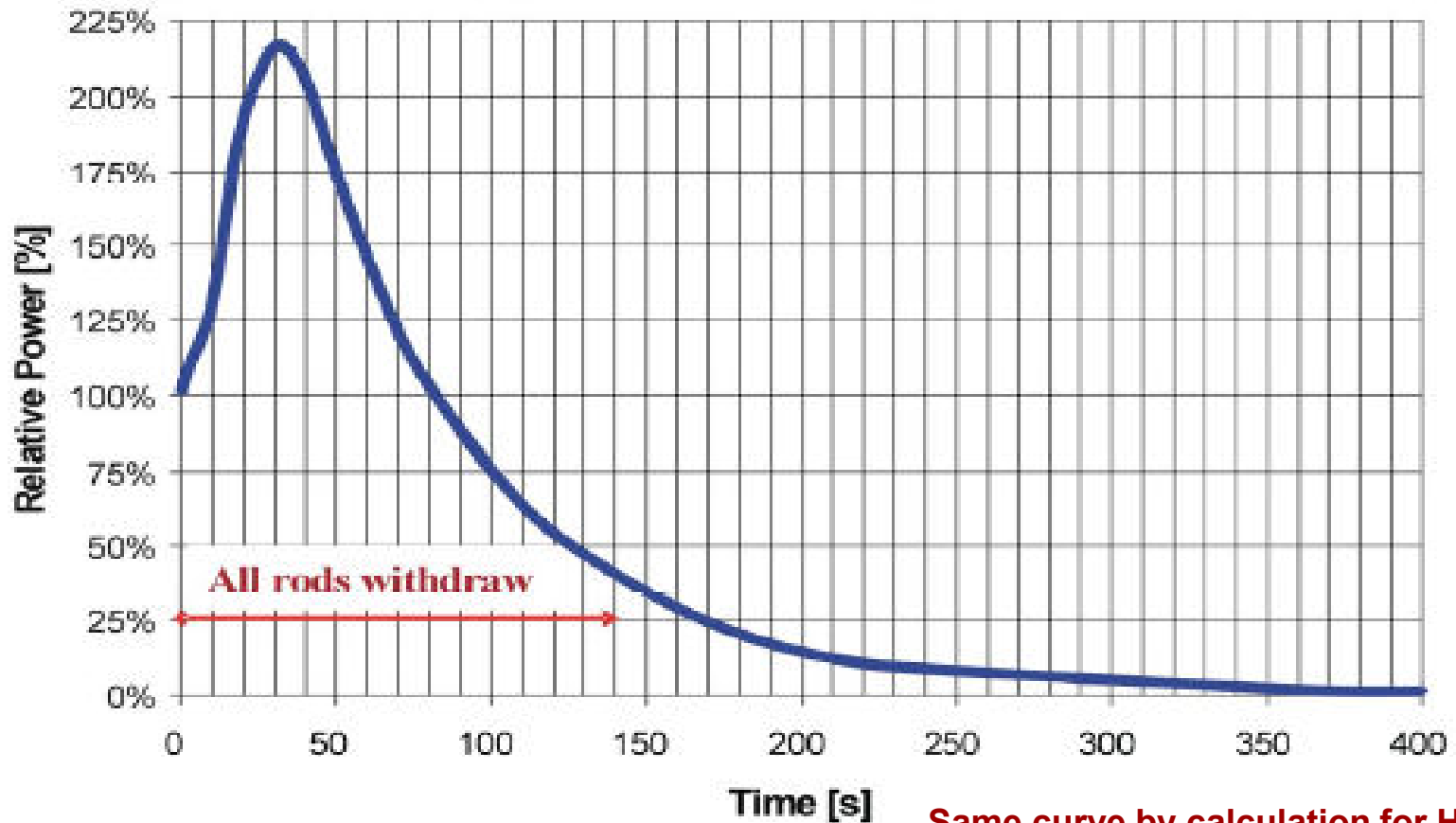

Same curve by calculation for HTR-MODULE

Recriticality of the HTR-10 EXPERIMENT

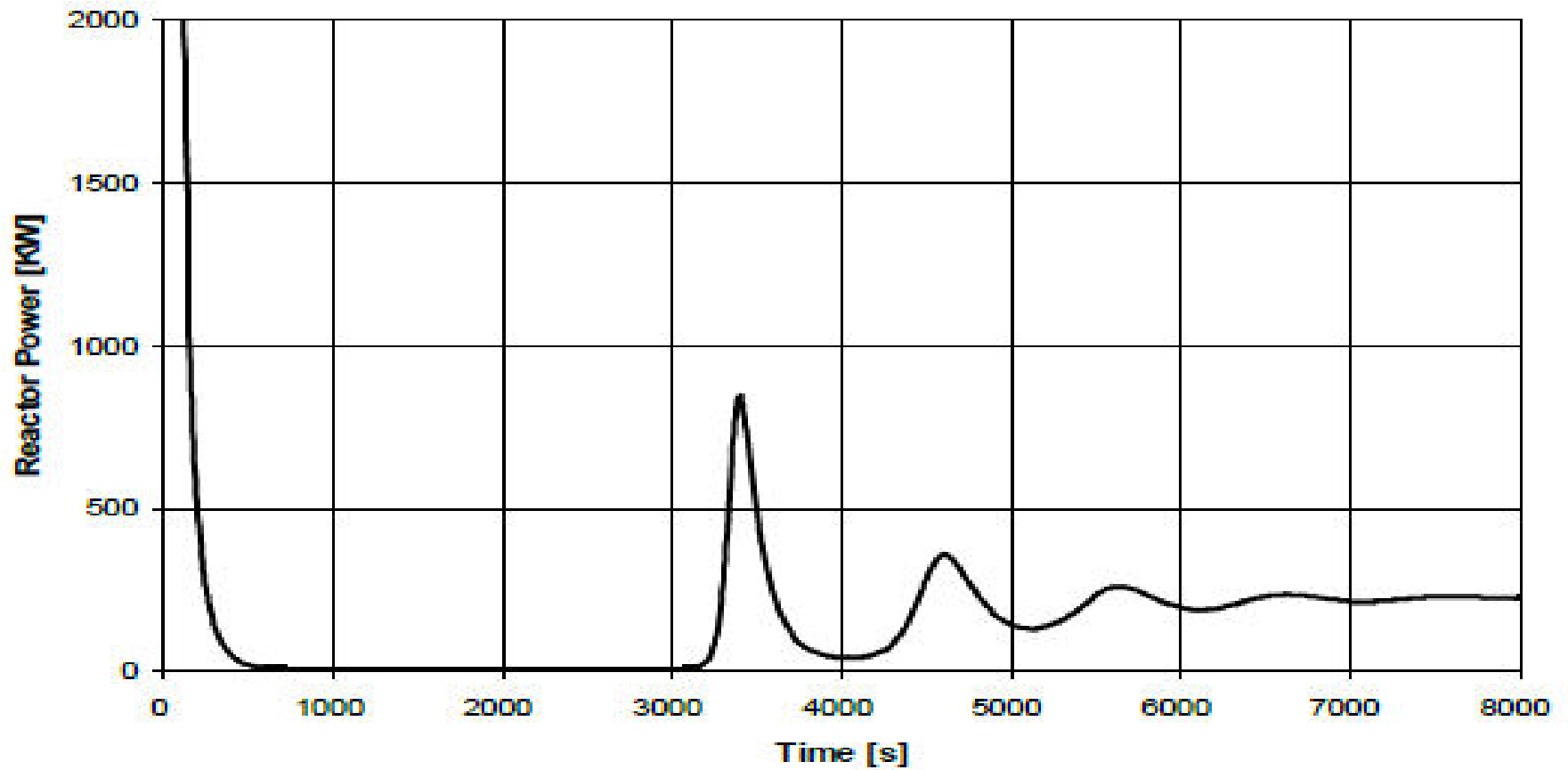

Same curve by calculation for HTR-MODULE

DECAY HEAT VS TIME

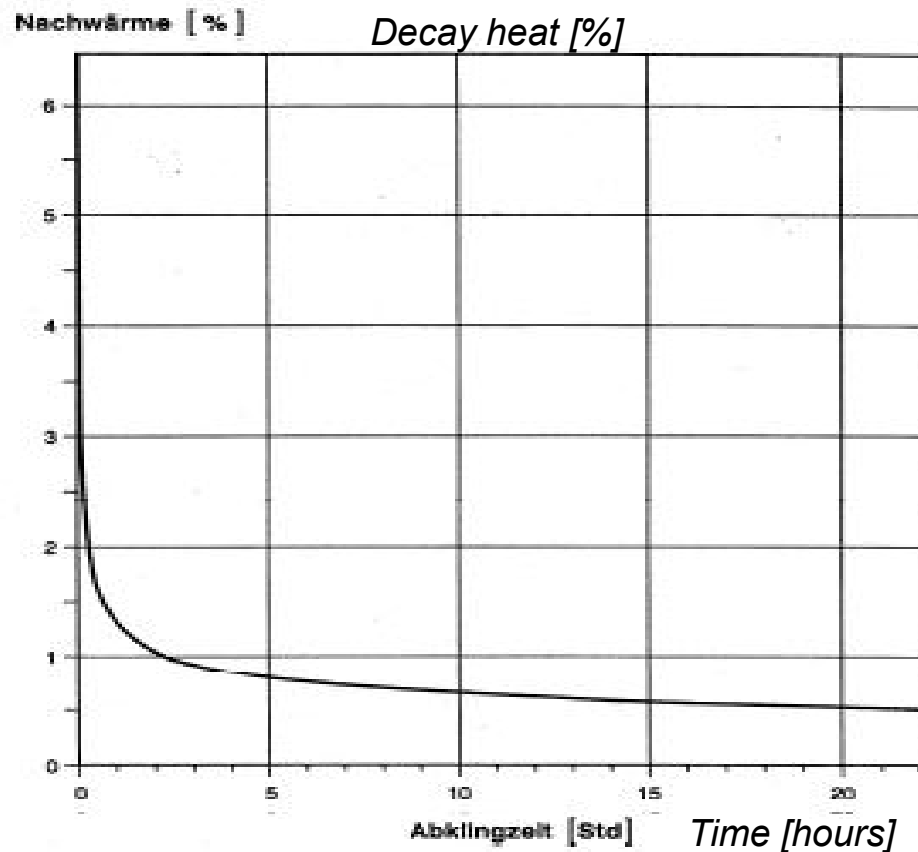

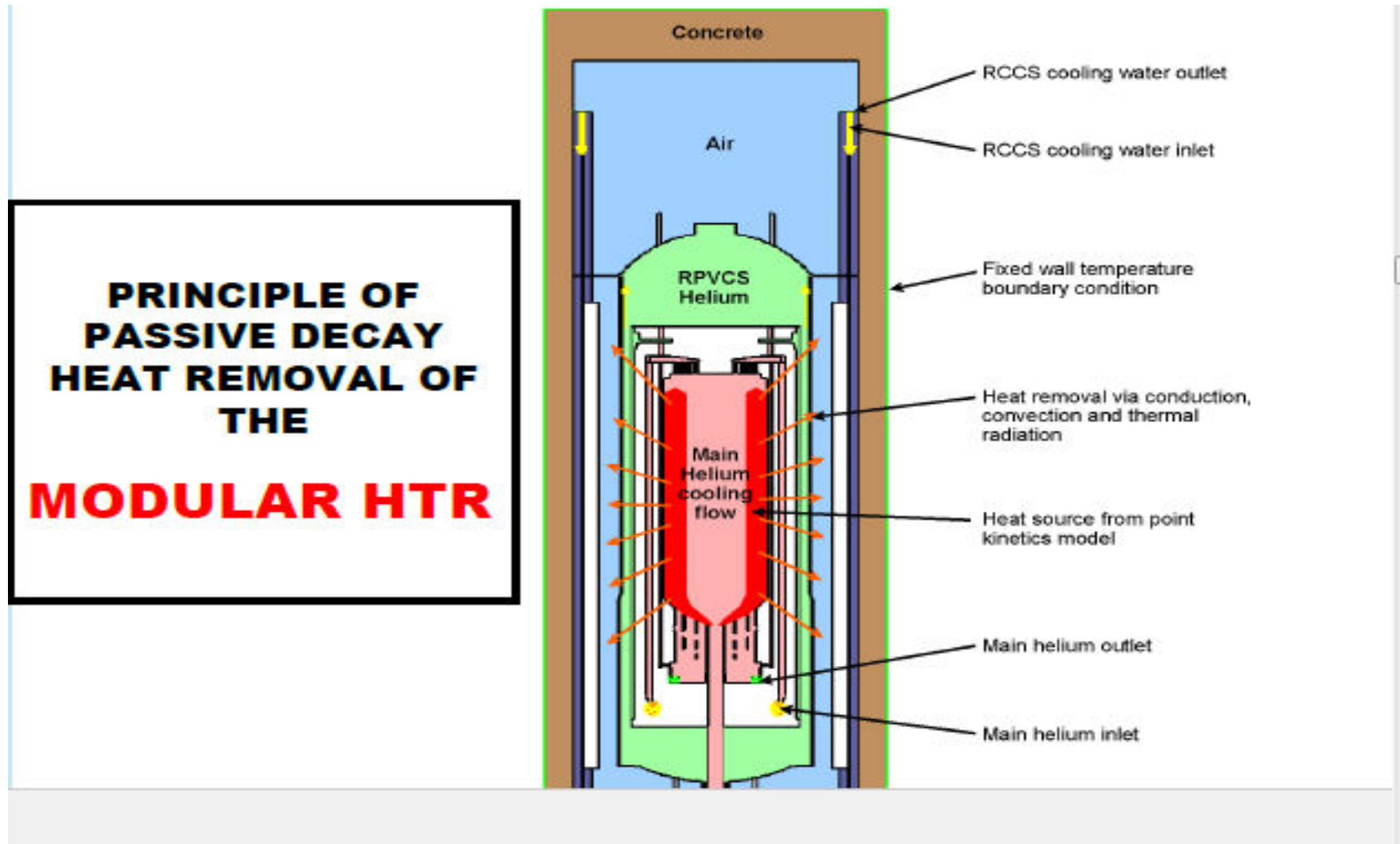

Decay Heat

MAXIMUM FUEL TEMPERATURE VERSUS TIME (p= 1bar)

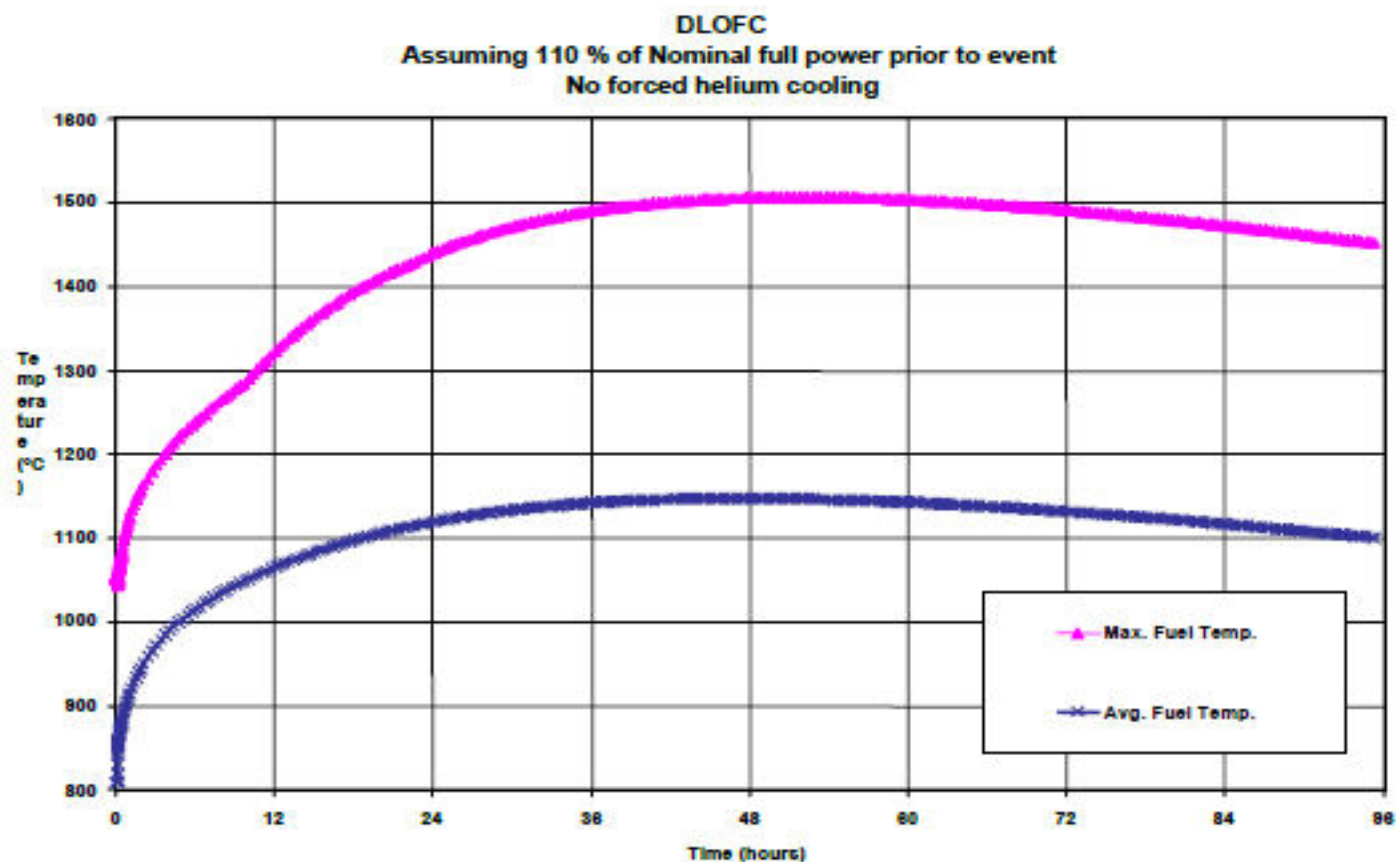

*HTR-MODULE
200 MWth*

- Even without cooling by the cavity cooler the fuel temperature is only increased 10 to 20 °C

SafeG GFR Summer School

Husinec-Rez, Czech Republic, 29.08.-01.09.2022

Safety Analysis – Radiological Accidents HTR-MODULE

Dr. Gerd Brinkmann

**BriVaTech Consulting
Andreas-Sapper-Str. 15
91334 Hemhofen**

phone: +49 9195994747

mail: gerd.brinkmann@gmx.de

The aim of design using barriers is:

- **The minimization of radioactive releases during normal operation and accidents.**
- **Knowing the design of an HTR the accident analyses have to demonstrate with adequate safety margins that the radioactive releases are far below the governmental dose limits.**
- **So the question is:
What is the quality of each barrier and the quality of all together against radioactive releases?**

(Here: the confinement question is not a question of barriers against external events)

First Barrier:

Fuel particles:

More or less a safe confinement of radioactivity
(depending on burn up and temperature)

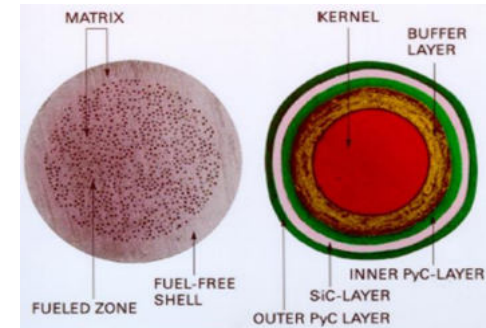

Quality of this first barrier is given by the failed Particle Fraction Curve

In general during licensing procedures the data for calculation are about one magnitude higher than the expected values.

So this curve is the starting point for the discussion confinement/
containment.

For HTR Module (Siemens design) the curve was based on the German fuel tests.

HTR-Module Siemens Design - Maximum Failed Particle Fraction as a Function of Fuel Temperature

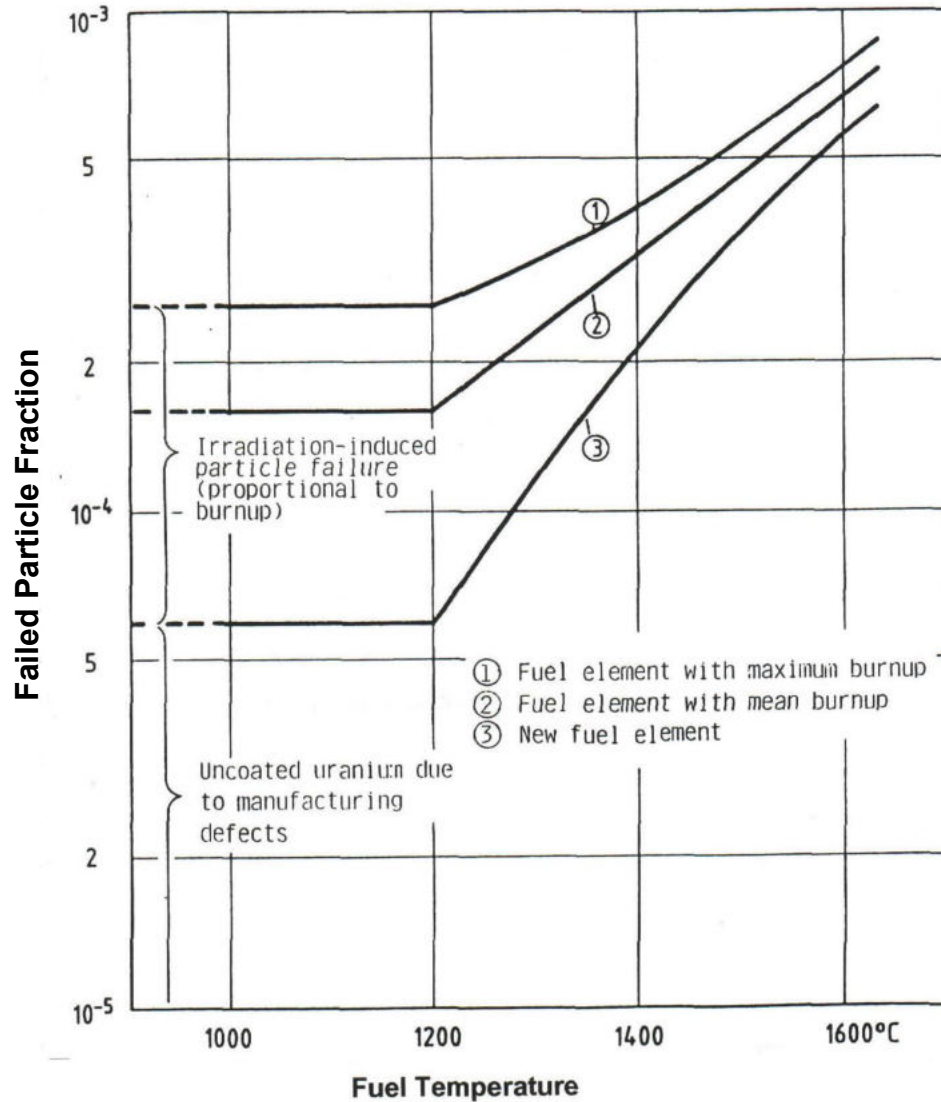

HTR-Module Siemens Design - Peak Temperature versus Time Diagram

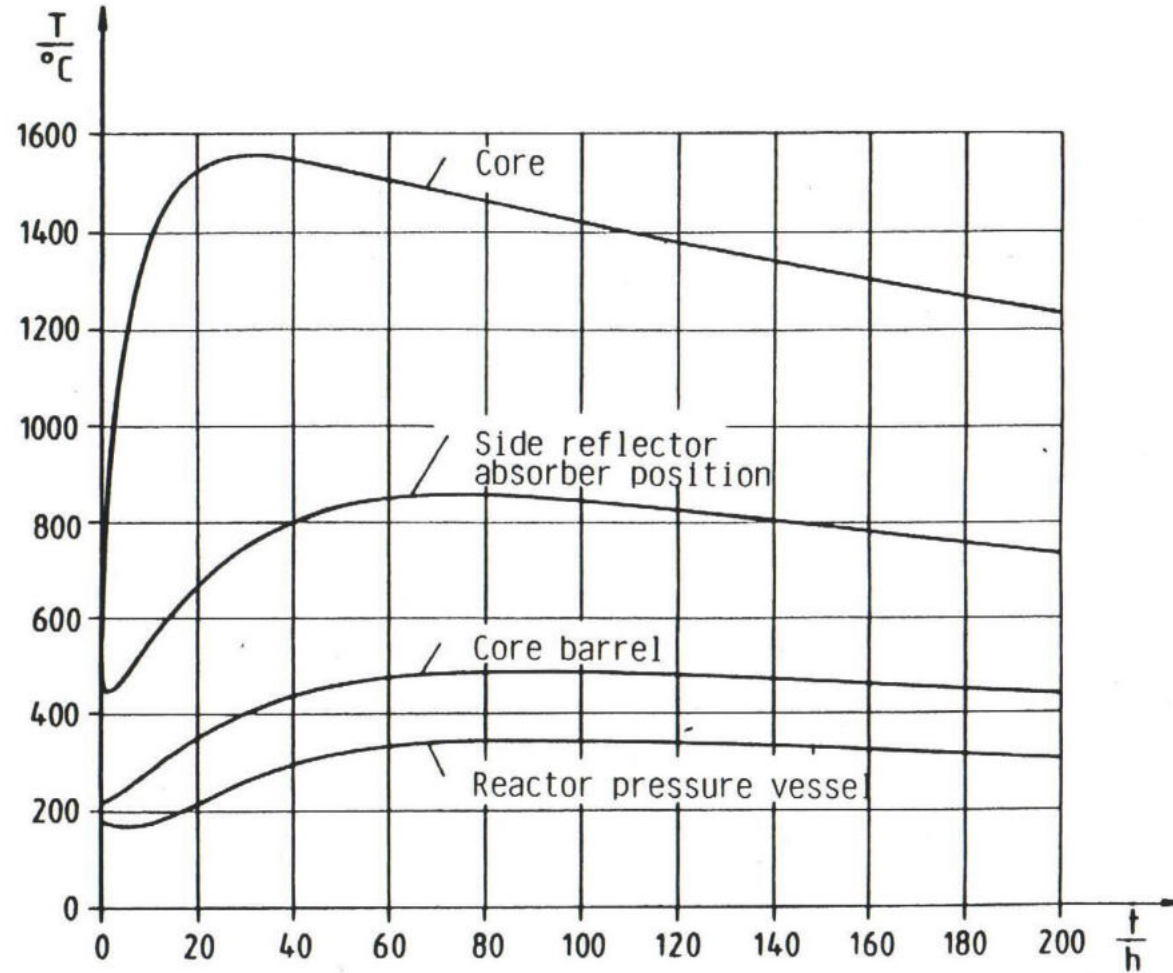

HTR-Module Siemens Design - Volumetric Fractions of Core at certain Temperatures, Core Heat-up Phase

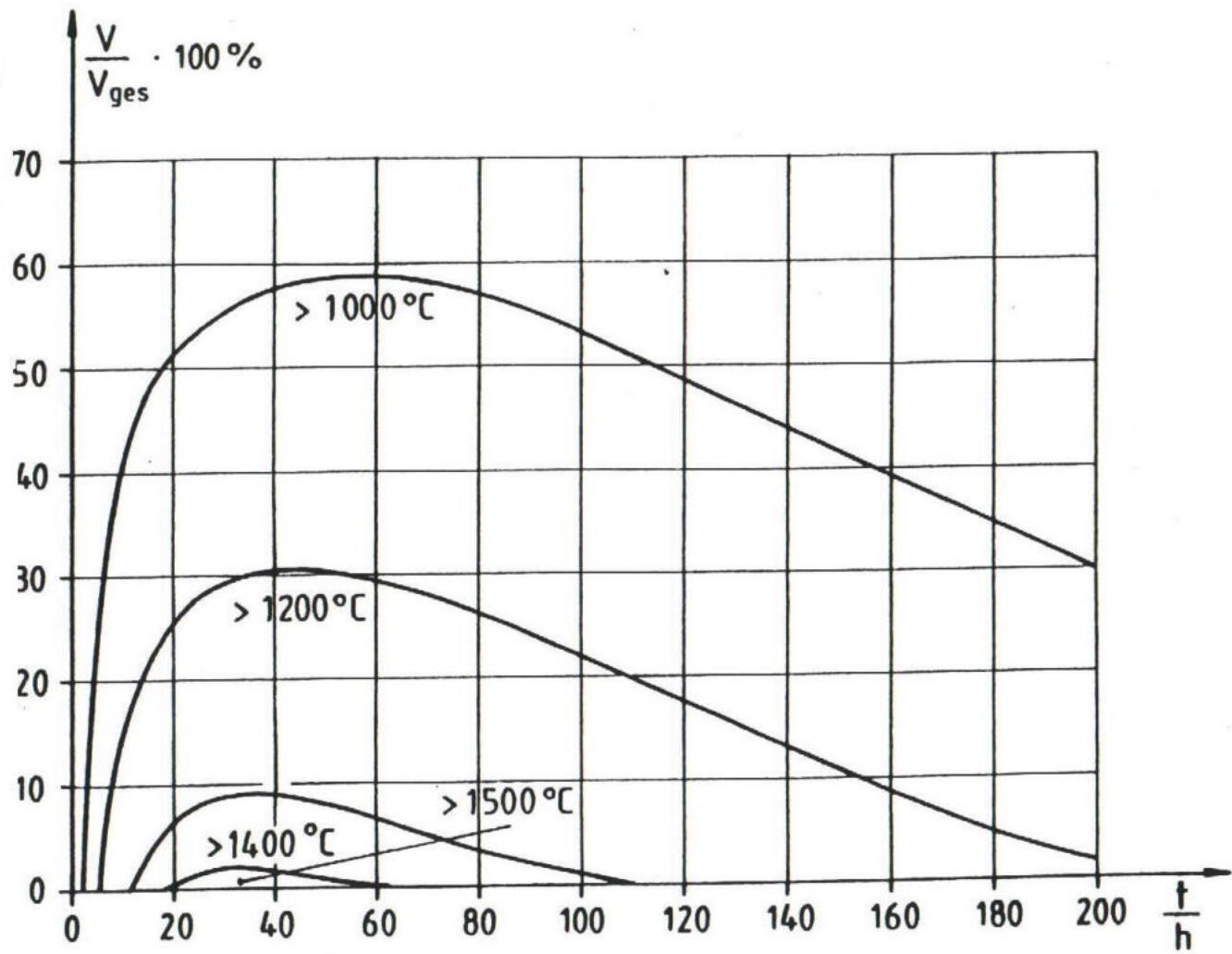

Second Barrier:

Primary gas envelope (primary boundary):

More or less a good confinement of radioactivity (depending on the quality of the components and pipings)

Using the quality of LWRs (nucl. grade class 1 - whatever that means in different countries):

You can use the break postulations (state of the art):

- **no through wall cracks in vessels**
- **2A breaks in pipings with known probability**

If you change the quality of the second barrier, you have to strengthen the first or the third barrier.

HTR-Module - Second Barrier:

For the HTR Module it was postulated (like PWRs in Germany)

- **small breaks (DN10) - unisolable (Quality class for small piping)**
- **large breaks (DN65) - isolable (Quality class 2)**
- **large breaks (DN65) - unisolable (Quality class 1)**
 - **low probability**
 - **only a few connections to the vessel**

Event Classification for HTR-Module Power Plants

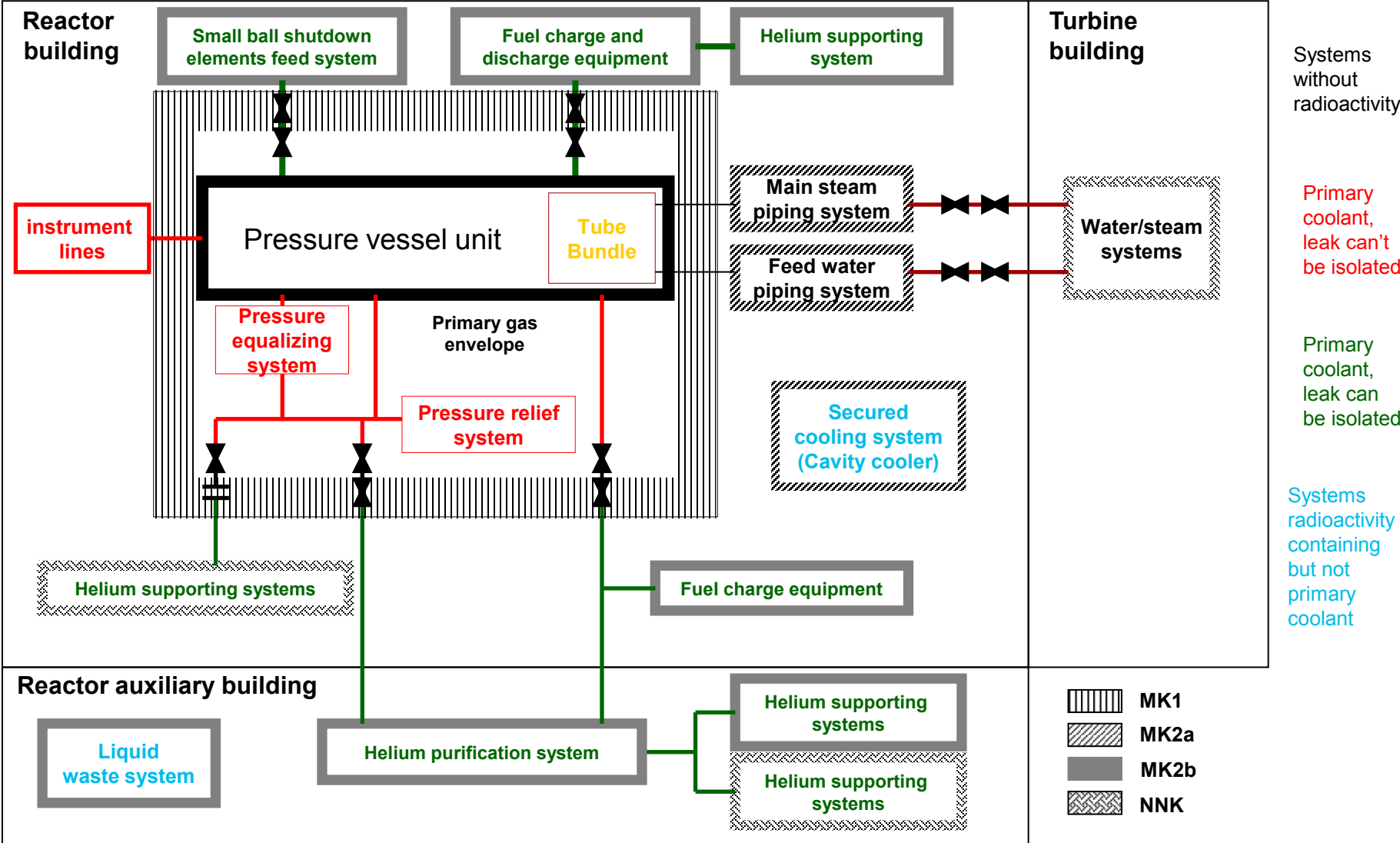

HTR-Module - Small Breaks (DN10)

Assumptions:

**Scram signal delayed to the break.
Time of pressure loss several hours.
No dust release out of the core.
No pressure build up in the building.
Release by the stack (normal path).**

Radioactive release:

	filtered	unfiltered	
noble gases	6.2 E+11	6.2 E+11	(Bq)
iodine	3.4 E+7	3.4 E+9	(Bq)
Sr, Ag, Cs	3.3 E+3	3.3 E+6	(Bq)

HTR-Module - Small breaks (DN10) (cont.)

Radiological Impact (dose)

	filtered	unfiltered		limit
whole body (adult)	8.42 E-7	2.43 E-6	0.05	(Sv)
thyroid (child)	5.70 E-6	4.88 E-4	0.15	(Sv)

Result:

Impact far below the limits

Decision:

Filters are not safety related, so in the licensing procedure the reference case is the unfiltered one.

HTR-Module - Large Breaks (DN 65) - isolable

Assumptions:

Direct counter measures of reactor protection system (scram, actuation of isolation valves).

Pressure build up in the building relatively low.

Release by the stack (normal path).

Radioactive Release:

Depending on the broken system, the helium purification system is covering all other systems.

HTR-Module - Large Breaks (DN 65) - isolable (cont.)

Radiological Impact (Dose)

	unfiltered	limit
whole body (adult)	6.68 E-6	0.05 (Sv)
thyroid (child)	2.63 E-4	0.15 (Sv)

(Values coming from calculations for a break in the auxiliary building).

Result:

Impact far below the limits

Decision:

Filters are not safety related, so in the licensing procedure the reference case is the unfiltered one.

HTR-Module - Large Breaks (DN 65) - unisolable

Depressurization Phase:

Assumptions:

Direct counter measures of reactor protection system.

Depressurization time of about 3 minutes.

Pressure build up in the building.

Relief dampers to the stack open.

Radioactive Release

- **Content of the primary circuit**
- **Content of helium purification system incl. desorption of filters**
- **Desorption of surface activity in the primary circuit**
- **Dust (1 kg)**
- **No plate out in the building**

HTR-Module - Large Breaks (DN 65) - unisolable (cont.)

		<i>Factor: design / expected</i>	
Noble gases	3.3 E+12	Bq	~ 3
Iodine	9.1 E+09	Bq	~ 100
Sr, Ag, Cs	5.3 E+06	Bq	~ 50
Tritium	5.6 E+12	Bq	~ 2
C14	6.0 E+10	Bq	~ 10
<u>Radiological impact (dose):</u>		<i>unfiltered</i>	<i>limit</i>
whole body (child)		9.76 E-06	0.05 (Sv)
thyroid (child)		5.45 E-04	0.15 (Sv)

HTR-Module Siemens Design

Contributions to the Source Term “Depressurisation Phase After Unisolable DN65 Pipe Break ” (Design Values)

Nuclide	Contribution in Percent			
	Steady State Coolant Activity	Desorption	Dust Release	Helium Purification System
Kr 88	83.2	-	-	16.8
Xe 133	9.9	-	-	90.1
J 131	23	71	6	-
Cs 137	18.6	57.4	24	-
Sr 90	< 0.1	< 0.3	99.7	-
Ag 110m	9.3	28.8	61.9	-
H 3/C 14	2.0	-	-	98

HTR Module, Siemens Design

Core heat-up phase

Assumption:

- > All operating parameters very high (temperature, power)**
- > Failure of the first protection signal (single failure in reactor protection system - not normal in licensing)**
- > Combination (addition) of uncertainties result: about 130°K to the calculated values.**
- > Gas expansion in the vessel due to temperature increase will end after 160 hours with 9% vol. increase, end of release into the building**
- > No plate out in the building**

HTR-Module - Large Breaks (DN65) - unisolable (cont.)

Radioactive Release in the Building

	<i>Design</i>		<i>expected</i>	
	<i>T (lic.)</i>	<i>T (nom.)</i>	<i>T (lic)</i>	<i>T (nom.)</i>
<i>Iodine</i>	1.3 E+10	5.3 E+09	4.2 E+09	1.5 E+09

Radioactive Release to Environment

	<i>filtered</i>	<i>unfiltered</i>
<i>Xe 133</i>	2.7 E+11	2.7 E+11 (Bq)
<i>I 131</i>	1.3 E+08	1.3 E+10 (Bq)
<i>Ag 110m</i>	1.2 E+06	1.2 E+9 (Bq)
<i>Cs 137</i>	2.0 E+06	2.0 E+9 (Bq)
<i>Sr 90</i>	1.0 E+04	1.0 E+7 (Bq)

HTR-Module - Large Breaks (DN65) - unisolable (cont.)

Radiological Impact (Dose) Depressurization and Heat-up Phase:

	<i>filtered</i>	<i>unfiltered</i>	<i>limit</i>
<i>whole body (adult)</i>	<i>9.8 E-06</i>	<i>2.97 E-04</i>	<i>0.05 (Sv)</i>
<i>thyroid (child)</i>	<i>6.22 E-04</i>	<i>1.23 E-02</i>	<i>0.15 (Sv)</i>

Result:

Impact far below the limits.

Decision:

Filters are not safety related, so in the licensing procedure the reference case is the unfiltered one.

Confinement Envelope consists of:

- > Reactor Building (leak tightness 50Vol.%/day)***
- > Building pressure relief system***
- > HVAC system isolation***
- > Subatmospheric pressure system (filter) as operational system***

***This concept was accepted in the 80ies by TUV
Hanover (expert of Government Lower Saxony) and by
RSK (expert of German Federal Government)***

HTR-Module Siemens Design - Cross Section of Reactor Building

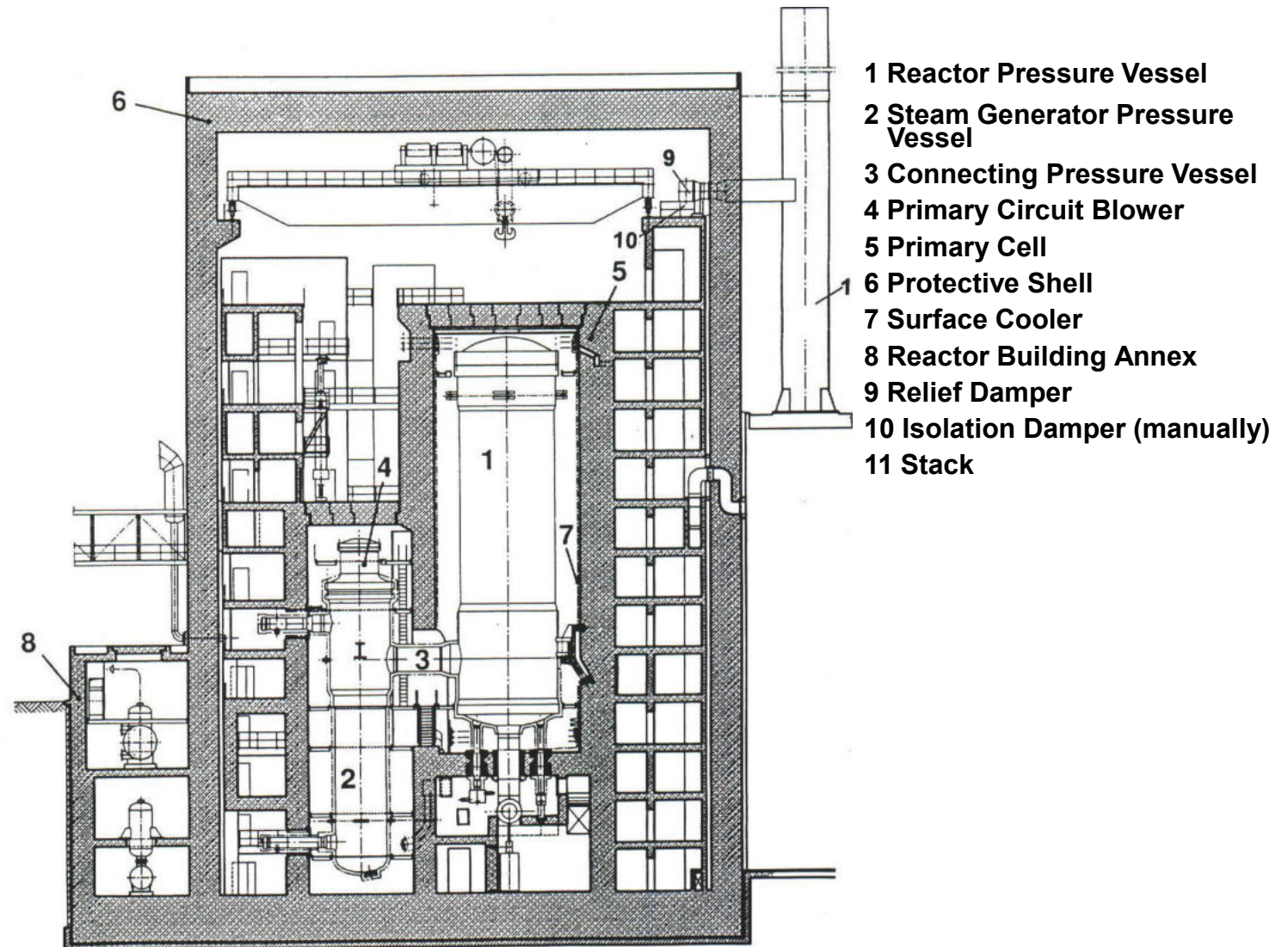

HTR-MODULE SIEMENS Design – Calculations with American Regulations in 2011

Design Basis Accidents	SAR (1988)	Dose (TEDE) Sv	
		EAB (2 hour) ⁽¹⁾	NRC Limit ⁽²⁾
Break of a Large Connecting Pipe (DN 65) - LBLOCA short-term unfiltered release	6.2.3.1.1	unfiltered: 1.361E-04 (13.61 mrem)	2.5E-1 6.3E-2 2.5E-2
Break of a Large Connecting Line (DN 65) - LBLOCA long-term unfiltered release with core heat up	6.2.3.1.2	filtered: 2.858E-06 unfiltered: 2.214E-04 (22.14 mrem)	
Instrument Line Break Pressure release phase (DN <10)	6.2.3.3	filtered: 5.183E-05 unfiltered: 5.782E-05 (5.782 mrem)	
Steam Generator Tube Rupture with response of the Pressure Relief System	6.2.5.2	filtered: 2.245E-06 unfiltered: 3.464E-05 (3.464 mrem)	
Helium Purification System Pipe Break release via stack	6.2.6.1	unfiltered: 1.975E-04 (19.75 mrem)	
Non-Design Basis Accidents			
Leakage of Vessel Containing Radioactive Contaminated Water	6.2.6.2	Unfiltered: 2.443E-06 (0.2443 mrem)	10CFR20
Seismic Effects on the Reactor Auxiliary Building	6.2.7	Unfiltered: 3.961E-04 (39.61 mrem)	

Notes:

- (1) The worst two hour window is used with an atmospheric dispersion factor (X/Q) value of 3.35E-03 s/m³ corresponding to an EAB distance of 0.249 miles (400 m).
- (2) The 0.25 Sv criterion is used for evaluating design basis accidents of exceedingly low occurrence probability and low risk of public exposure to radiation. The criterion for events of moderate frequency is 25% of the 0.25 Sv, or 0.063 Sv. The criterion for events of higher probability of occurrence, the acceptance criterion is 10% of the full limit, or 0.025 Sv

GFR Summer School S-Allegro Facility

Tomas Melichar, Jan Šefl – CVR
31.8.2022



This project has received funding from the Euratom H2020 programme
NFRP-2019-2020-06 under grant agreement No 945041.

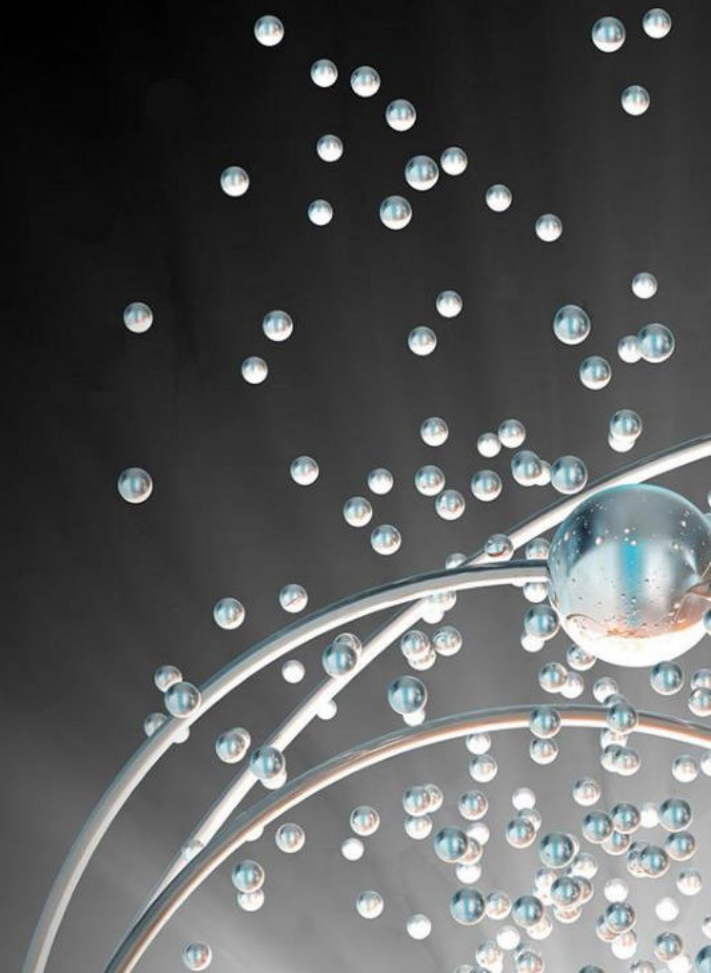

- Introduction of the facility
- Realization phases, components delivery, commissioning
- First experiments
- Current works
- Experimental possibilities

- A large-scale experimental facility S-Allegro has been built in Pilsen, Czech Republic at Research Centre Rez

Purpose

- The scale-down of the GFR concept ALLEGRO → to support development of ALLEGRO or other GFR concepts
- To verify the basic safety features and system behavior of the high-temperature helium systems
- To verify the passive decay heat removal system
- To simulate the accidental conditions
- Testing of components of HTH systems at relevant parameters
- Generation of data for codes validation
- To gain design, construction and operational experience

ALLEGRO Reference
Concept 2010



1/75
THERMAL POWER

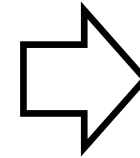

S-Allegro





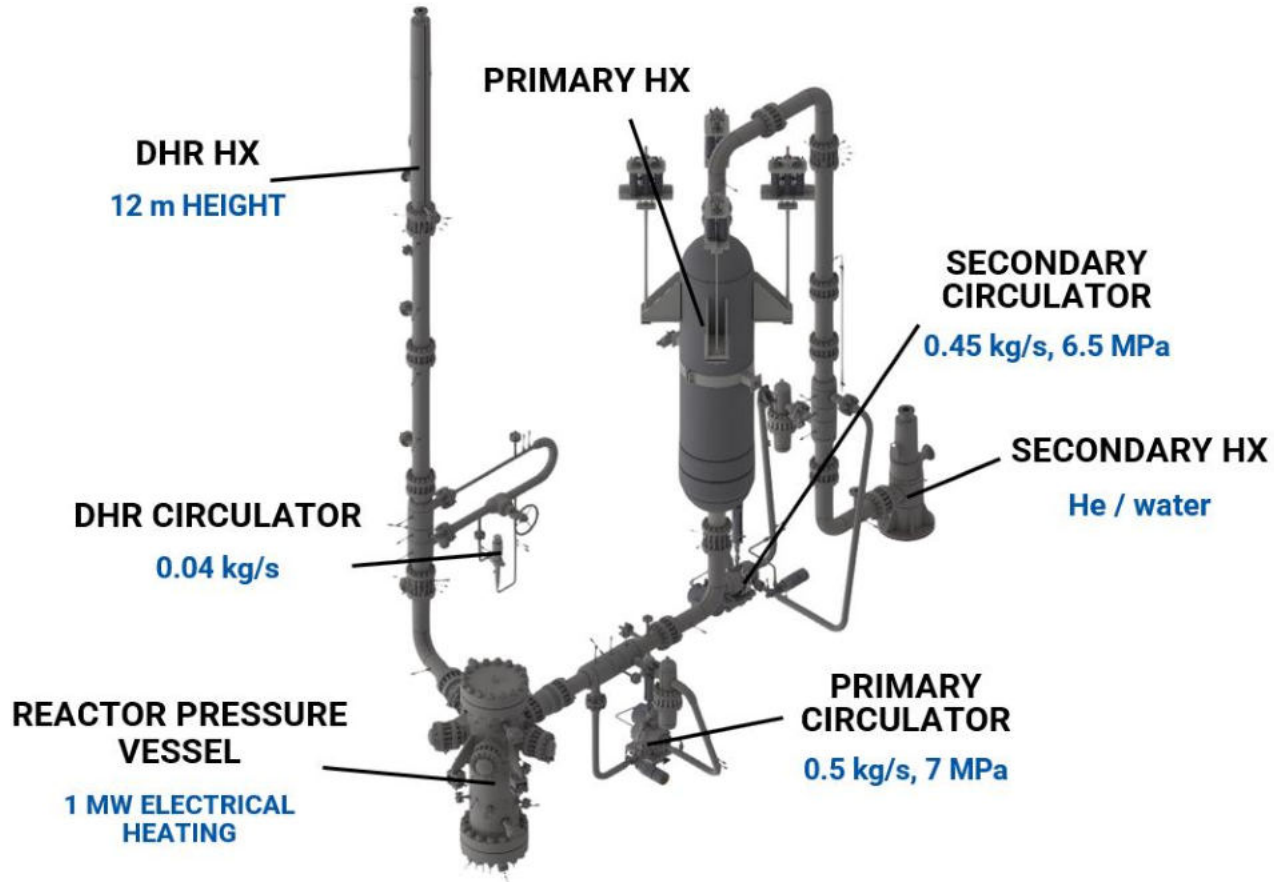

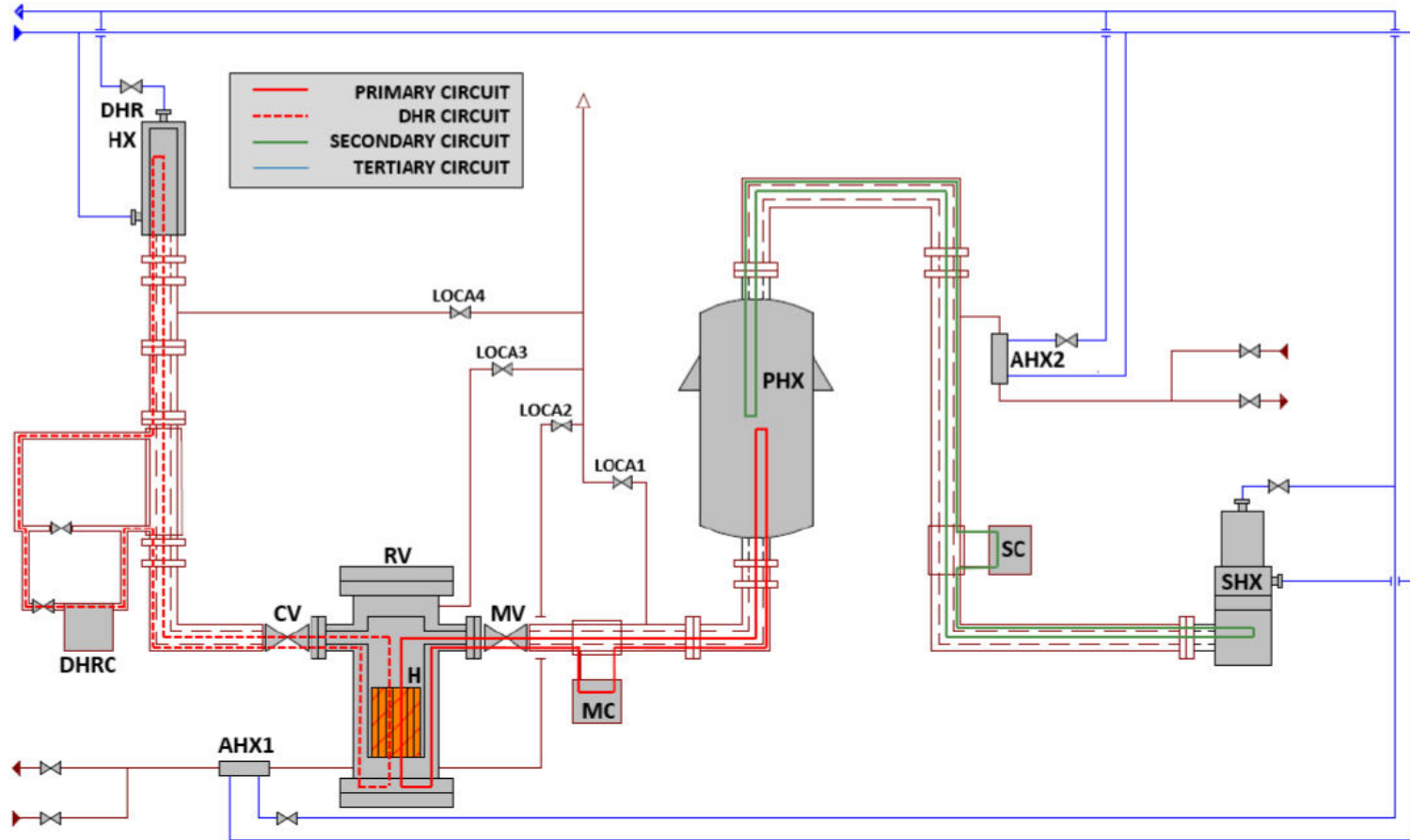

- S-Allegro facility built in the site of CVR in Pilsen, Czech Republic
- Realized within SUSEN project – project focused on building of research infrastructure to extend energy research possibilities
- Technical specification and requirements prepared by CVR
- Contract signed with ATEKO a.s. as the general contractor
 - Basic design, detail design, components fabrication, assembly, commissioning

Main suppliers

- ATEKO a.s. – general contractor, supplier of the mechanical part and circulators
- SUMO s.r.o. – control system
- ÚJV Řež a.s. – heating system
- Centrum výzkumu Řež s.r.o. – coaxial valves

Project Phases

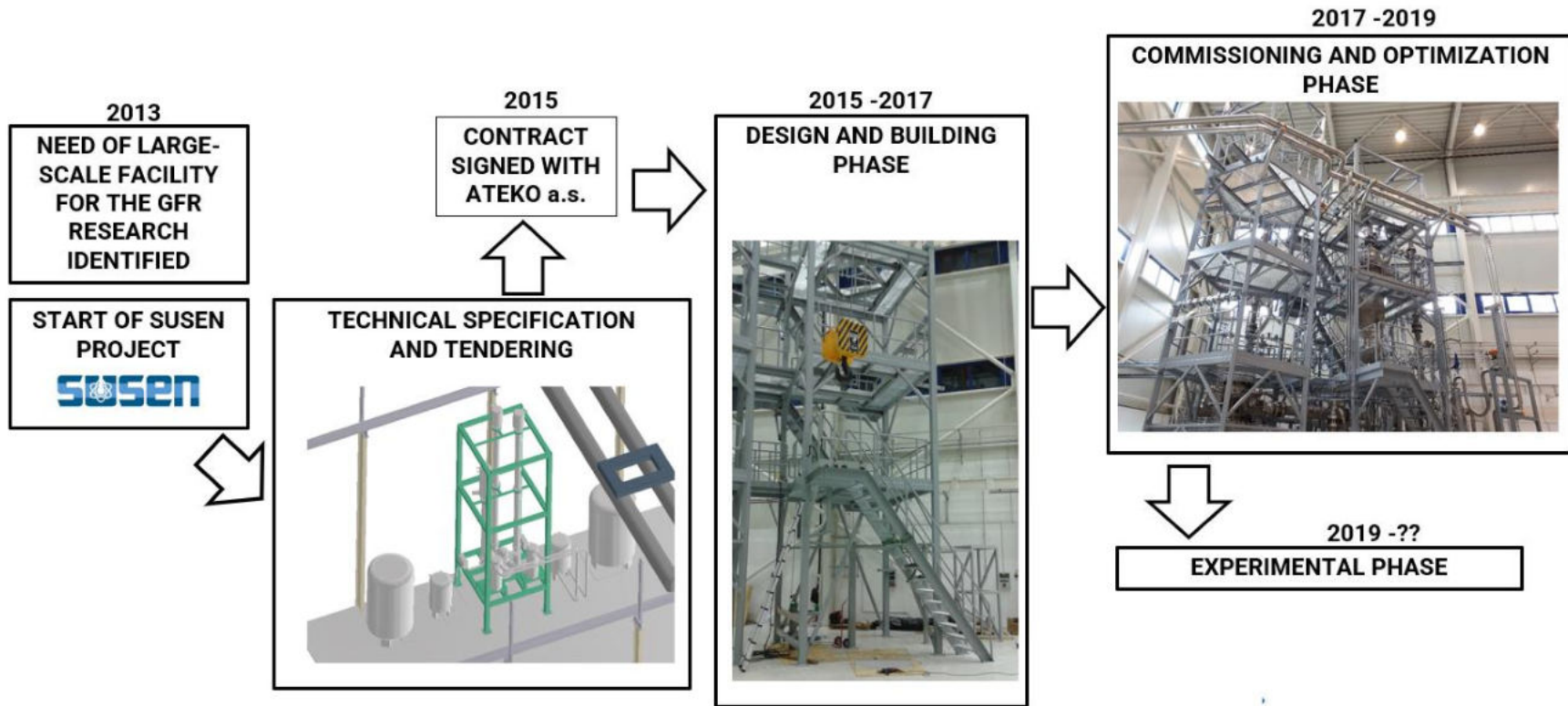

PRIMARY HEAT EXCHANGER



- 1 MW gas (helium / helium) heat exchanger
- coiled tube type
- 268 coiled tubes
- Coiled tubes length 1 300 m



REACTOR VESSEL



DHR LOOP



Primary circuit

Working fluid	Helium
Maximum temperature	850°C
Maximum pressure	7 MPa
Maximum mass-flow rate	0.5 kg/s
DHR loop height	12 m

Components Delivery

- Two coaxial valves developed and patented at CVR
- The function is to allow separation of the primary loop (main coaxial valve) and to allow preconditioning of the DHR circuit (cross-valve)
- Development process
 - Idea and conceptual study
 - Design, computational analyses, materials selection
 - Manufacturing and assembly
 - Installation in the facility
 - Testing and optimization



OPEN STATE

CLOSED/CROSSING STATE

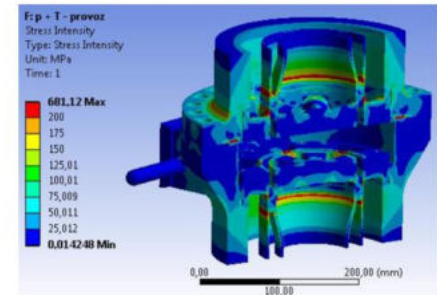
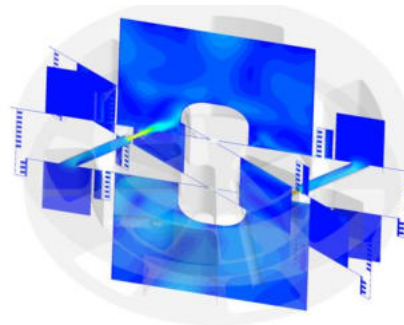

- Once assembled, the commissioning of the facility could started:
- Tightness and hydraulic pressure tests → always challenging in case of He
- Initial controls – pressure equipment, valves, electro, instrumentation
- Function tests – heaters, circulators, control system
- Thermal insulation
- Tests of control system alarms and trips → approx. 200 trips
- Setting of the safety guidelines and regulations
- Training of the operators
- Complex tests at operational parameters



Based on the commissioning tests, several shortcomings were detected → the system optimization was necessary before the complex experiments

- External tightness – optimization of the flanges sealing
- Internal tightness – coaxial joints
- Optimization of the control system and trips
- Optimization of compressors performance
- Geometric optimization of the cross valve
- Improvement of the primary circuit hydraulic resistance

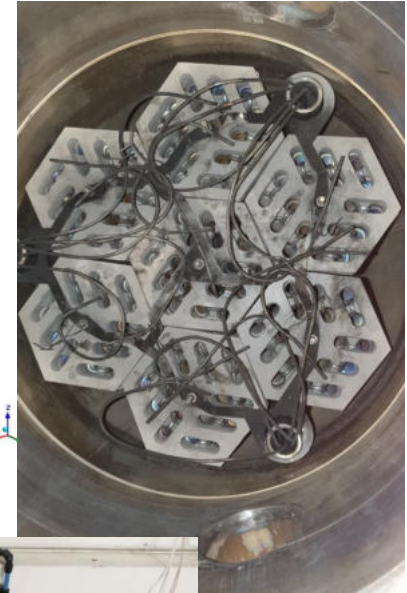
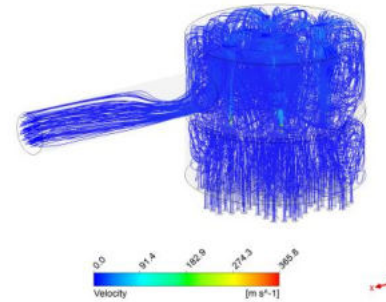

- The first experiments were performed in 2019 – 2021
- Performed within projects R4S LQ1603, TACR TK01030116 and H2020 Safe-G ID945041
 - Evaluation of energy balance and verification tests
 - Gathering of data for computational codes benchmarking

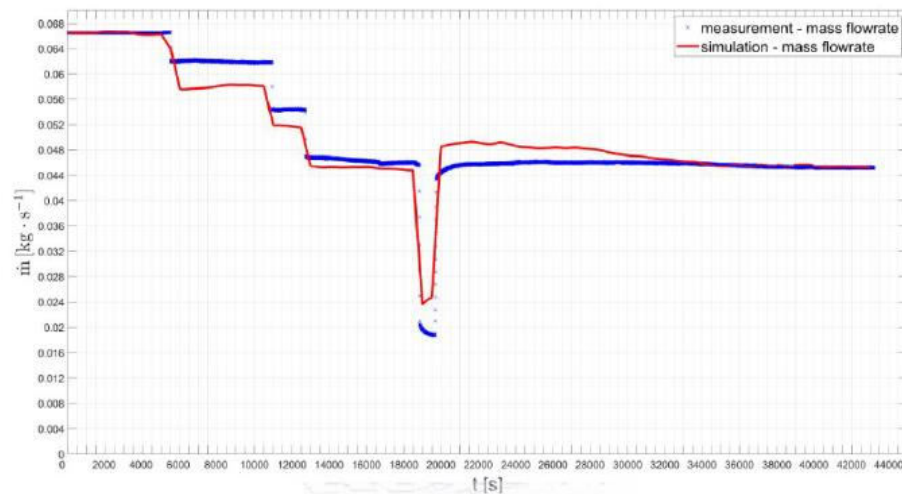
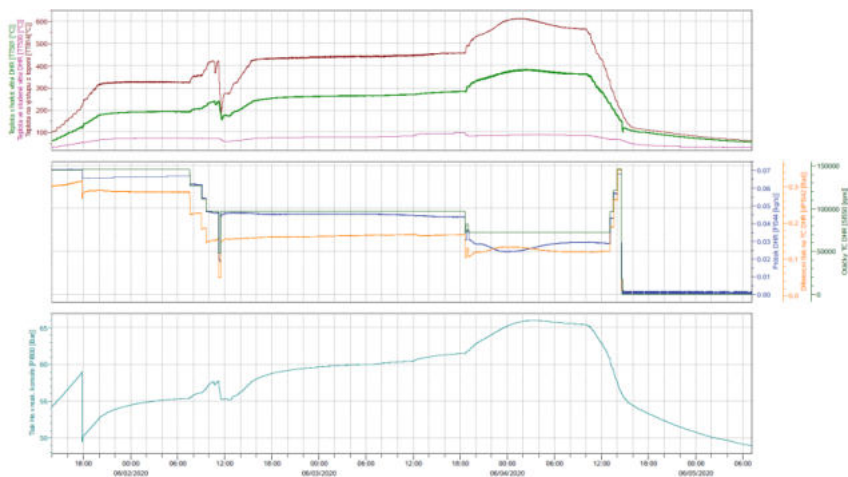

- Performed within projects TACR TK01030116
 - Experimental verification of the cross valve
 - Measurement on bypass of DHR circulator

**DHR
CIRCULATOR
BYPASS VALVE**

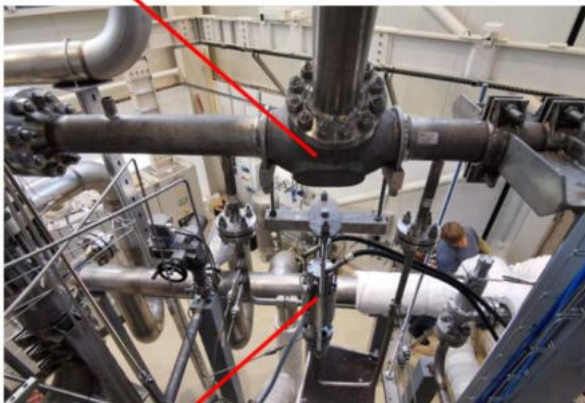

**DHR
CIRCULATOR**

**CROSS
VALVE**

**DHR LOOP
FLANGE**

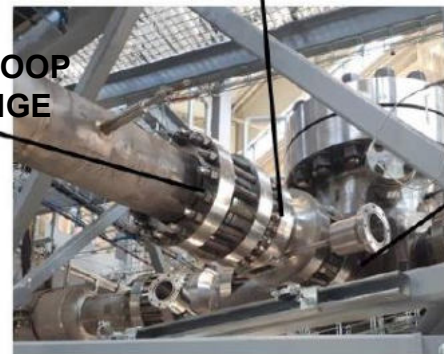

**REACTOR
VESSEL
FLANGE**

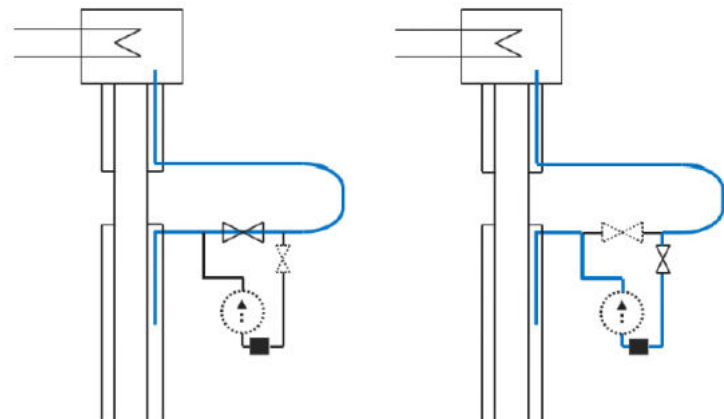

- Damage of the heating assemblies happened in 2021
- Sudden drop of the primary circulator, increase of the heaters temperature, partial damage failure of two heating assemblies
- Improving of the heaters design, delivery of new ceramic elements
- Improvement of the circulator control system
- Cleaning of the primary loop
- Re-assembly of the heating assemblies, insertion in the reactor vessel, operation renewal – before the end of 2022

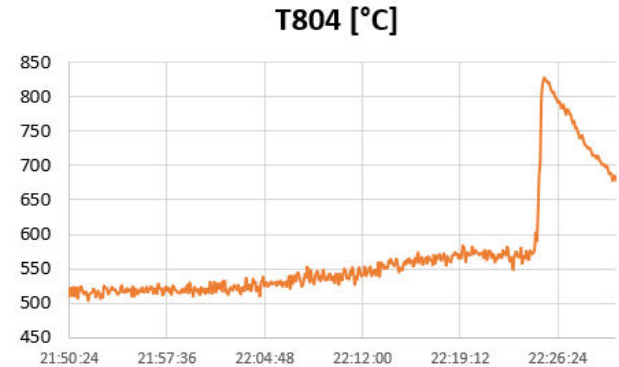

- Various experiments are possible and planned:
 - Normal operational regimes – steady-state operation, start up, shut down
 - Assessment of natural or combined convection in the DHR loop
 - Transition from normal to DHR passive operational regime
 - DHR loop preconditioning experiments
 - Decay heat removal simulation
 - LOHS accidents simulation
 - LOFA accidents simulation
 - LOCA accidents simulation – using special LOCA valves
 - Components failure simulation
 - Heavy gas injection
 - Components testing

Advanced manufacturing technologies (AMT).

Udi Woy, USFD

SafeG

SAFETY OF GFR THROUGH INNOVATIVE MATERIALS,
TECHNOLOGIES AND PROCESSES



This project has received funding from the Euratom H2020 programme
NFRP-2019-2020-06 under grant agreement No 945041.

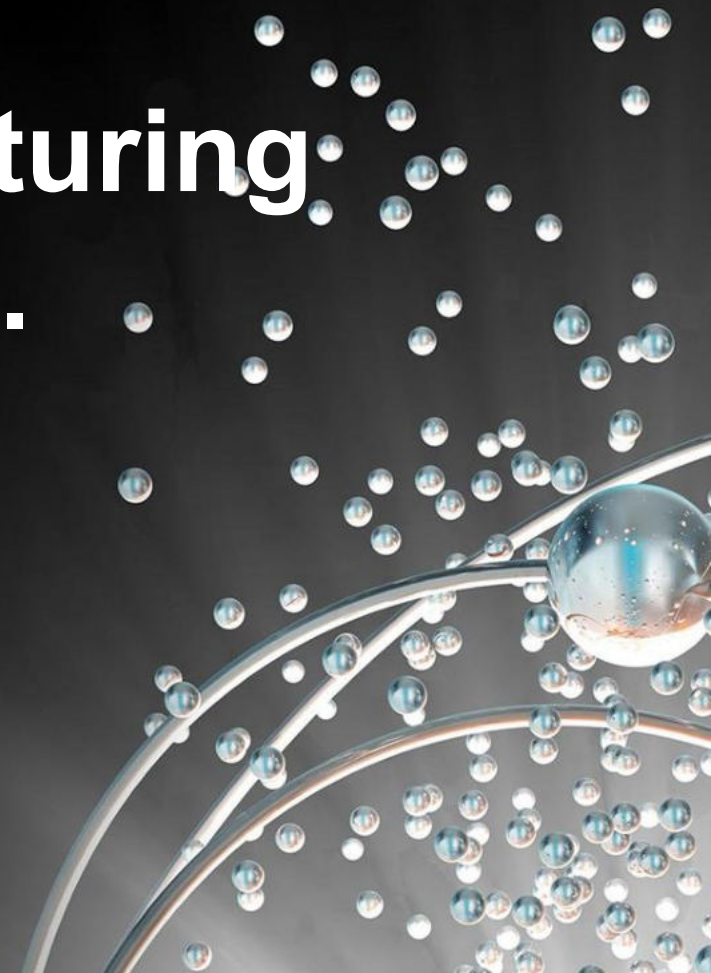

Why AMT?

Advanced Manufacturing Technology:

Technology – *Applied knowledge*

Advanced technology - *Promising new or developing innovation*

Manufacturing technology - *Techniques and processes designed to create or improve*

Promising techniques for processing suitable GFRs materials & components

For temperatures above 800 °C, such as those targeted in GFRs and HTRs, no steel can be employed, except for high Ni austenitic steels, such as the alloy 800. In this case, Ni-based alloys (e.g., Inconel 617, Haynes 230, and Hastelloy XR) are suitable options for components outside the core, particularly heat exchangers (not only for GFRs and HTRs) and power conversion systems. However, these alloys suffer from severe irradiation embrittlement and swelling. Therefore, their use in the core can be critical. Structural material behaviour important for reliable performance includes the following.

Objectives

To propose and assess adequate innovative materials with better performance, and investigate advanced manufacturing processes and technologies.

Approach

- Technical (x4)
- Project management (x1)
- Education & training (x1)
- Dissemination & exploitation (x1)



Task 2.3 Advanced manufacturing processes (USFD, CVR, KU, NCBJ)

- The aim of T2.3 is to assess the suitability of these processes for design and construction of GFRs.
 - Phase 1: establishment of clear definition for critical parts with the development of an approach to overcome challenges of GFR design (component, scale, geometry and material properties).
 - Phase 2: manufacturing of different materials will be performed.

Requirements analysis & material selection

ALLEGRO Design Considerations

Philosophy for the ALLEGRO core design (unique feature)

- Three distinct phases of operation → three different core config
 - STARTING MOX (or UOX) CORE**
 - Design fuel in 55 MOX < 20% Pu) → Physics-based fuel. Fuel Assembly
 - Core outlet temperature limited to 320°C
 - INTERMEDIATE CORE (contains 1 to 3 refractory FAs)**
 - Exp. refractory FA: (2 Pu) carbide pellets in BCC-BCC pins (20-30% inside thermally insulated metallic box, wt)
 - Outlet temperature: Test assembly $400-650^{\circ}\text{C}$ (reduced flow rate w/ average core 430°C)
 - FINAL REFRACTORY CORE**
 - Average core outlet temperature increased to $400-650^{\circ}\text{C}$
- Remark: ALLEGRO must be designed for the high-temperature option

Predominant focus on the higher temperature core design as main technology differentiator/ USP.

Research focus

ALLEGRO CEA 2009 (75 MW Design of I. circuit)

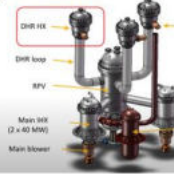

DHR HX used as basis for defining critical design features and related manufacturing parameters

Manufacturing Challenge

The main objective of this study is to evaluate the development of the design of the reactor core, including the design of the fuel elements, the core structure, and the associated systems. The design of the reactor core is a complex task, involving the selection of materials, the design of the fuel elements, and the design of the core structure. The design of the reactor core is a complex task, involving the selection of materials, the design of the fuel elements, and the design of the core structure. The design of the reactor core is a complex task, involving the selection of materials, the design of the fuel elements, and the design of the core structure.

- Operating requirements (Helium/ Water)
- Balancing experimental and testing plans within budget.

Material selection

Ten alloys are identified for use at design temperatures equal to or greater than 870°C (1600°F). They are:

- Alloy 617
- Alloy 602CA
- Alloy 556
- Alloy 800H
- Alloy 800HT
- Alloy 130
- Alloy 230
- Alloy HX
- 255 MA
- Alloy 625

The applicable corrosion environment, and the associated technical data (NHE) is to determine the design of the reactor core, including the design of the fuel elements, the core structure, and the associated systems.

Candidate materials & IN617 focus influenced by design requirements & regulatory (codes) considerations.

Alloys	UNS No.	T _{max} (°C / °F)	No. 1	No. 2	No. 3	No. 4	No. 5	No. 6	No. 7	No. 8	No. 9	No. 10
617	N06617	963(1800)	32	-	-	-	-	-	-	-	-	-
602CA	N06023	963(1800)	62	-	-	-	-	-	-	-	-	-
556	R06050	890(1650)	21	-	-	-	-	-	-	-	-	-
800HT	N08811	890(1650)	13	-	-	-	-	-	-	-	-	-
800H	N08810	890(1650)	33	-	-	-	-	-	-	-	-	-
357	N08330	890(1650)	18	-	-	-	-	-	-	-	-	-
250	N06250	890(1650)	17	2	2	2	-	14	-	-	-	46
HX	N06093	890(1650)	47	20	22	9	-	0.6	0.5	-	-	42
255MA	N08813	890(1650)	11	-	-	-	-	-	-	-	-	21
625	N06625	871(1600)	40	3	22	9	4	-	0.3	-	-	41
C-276	N10276	670(1250)	78	-	16	16	-	4	3.5	-	-	40
C-22	N06022	670(1250)	77	-	22	14	-	3	-	-	-	40

Task implementation

Development strategy

Building blocks (Budget)					
Test level	Coupons	Elements	Critical features	Sub-component	Component
Fabricability	x				
Stability & Repeatability	x	x			
Equivalence	x	x	x	IS or OS?	
Qualification	x	x	x	IS or OS?	IS or OS?

Test	Fabricability	Stability & Repeatability	Equivalence (Demo part)	Qualification (Sub-component/ component)**
Objective	Evaluate representative manufacturability of alloy via AM	- Establish process control/accuracy, reliability, and tolerance (critical flaws and characteristics, incl. fracture & fatigue*)	- Establish geometric criteria can be achieved (product form) - Demonstrate equivalent properties/ structural (base/reference vs AM) material behaviour can be achieved. (product function)	Qualify pre-production considerations for progression to high MRL/TRIL.
Outline	- Visual inspection - NDT (CT scanning/x-ray/ radiography/UT) - Bend test (quality control test to ensure consistency and assess material ductility/soundness)	- Visual inspection - NDT (CT scanning/x-ray, leak test.) - Heat treatment - Chemistry (Ni, Fe, Cr, Mo, Nb, W, Si & N) - Metallography (microstructure, porosity/features, grain characteristics) - Bend test (quality control test to ensure consistency and assess material ductility/soundness) - Hardness test (toughness resistance) - Density test (if powder AM and/or HIP procedure used)	- NDT - Heat treatment - Metallography (microstructure, porosity/features, grain characteristics) - Chemistry (Ni, Fe, Cr, Mo, Nb, W, Si & N) - Bend test (quality control test to ensure consistency and assess material ductility/soundness)* - Tensile test (strain at fracture) - Hardness test (toughness resistance)* - Charpy test (impact energy Charpy V-notch impact tests on representative test samples, at reference/lowest service temperature) - Creep test*	Recommendations on manufacturing route for DHR HX (or Inconel 617 alloy components) used for high temperature applications.
Notes	- Minimum of 4 specimens per test category	- Minimum of 4 specimens per test category, for stability verification - Minimum of 4 specimens per test category, for repeatability verification	- Minimum of 4 specimens per test category to demonstrate equivalence or establish	Out of scope but may be covered in reports based on defined objectives.

AMT focus

- Additive manufacturing (AM)



- Subtractive manufacturing (SM)

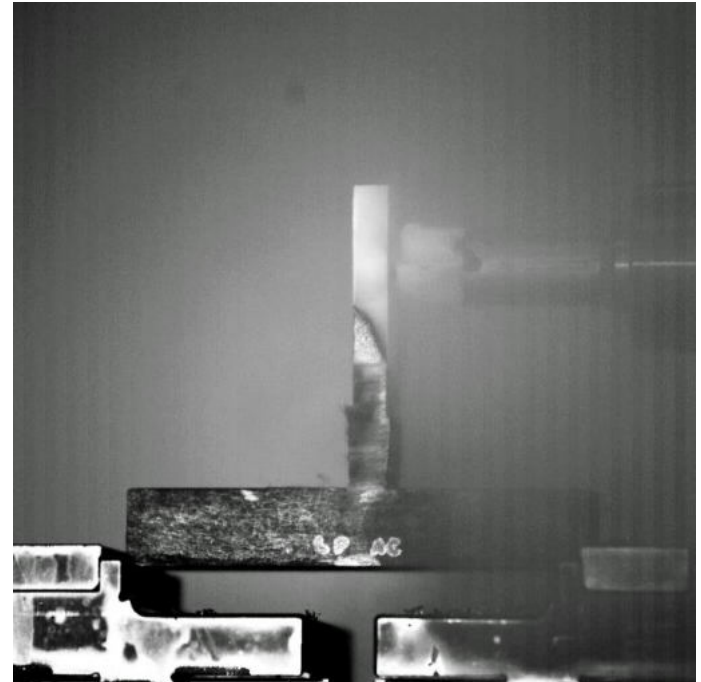

AM: Initial phase

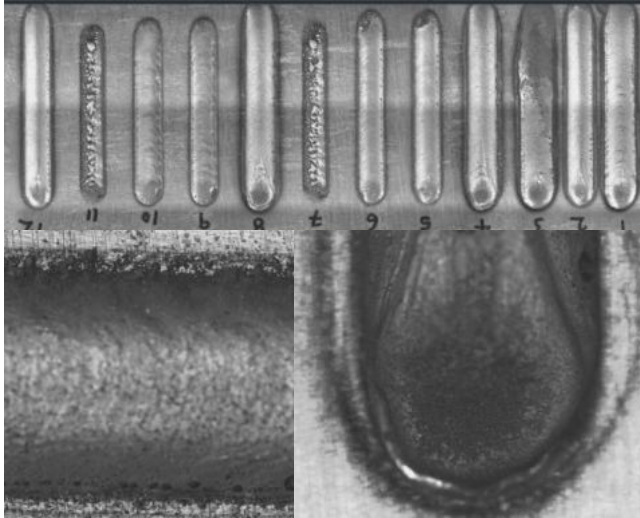

Laser-powder (LP) DED

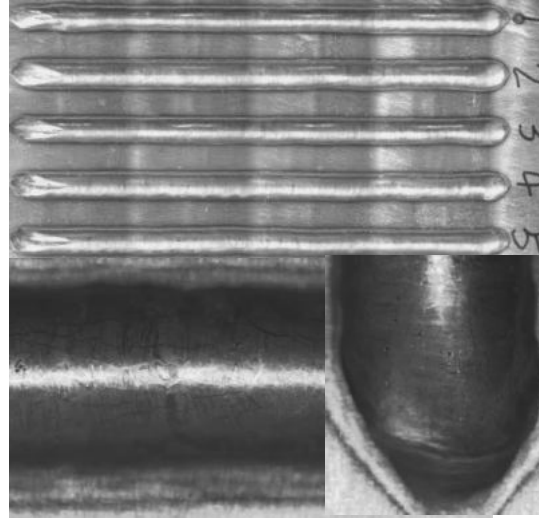

Laser-wire (LW) DED

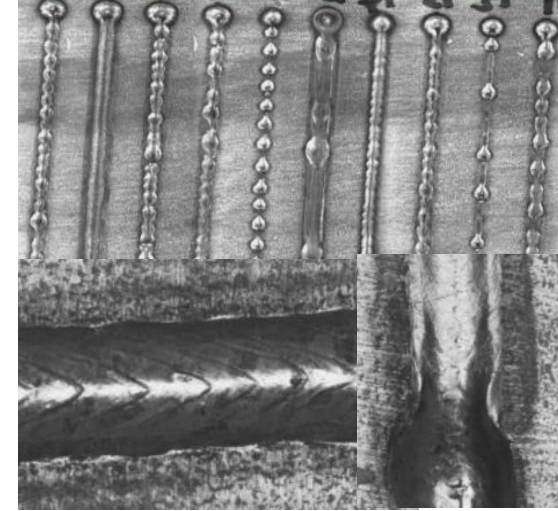

Arc-wire (AW) DED

AM: Intermediate phase

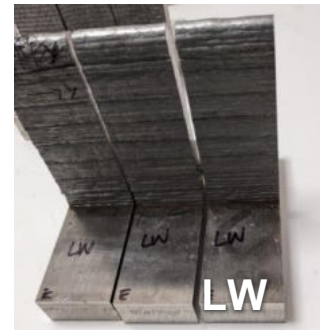
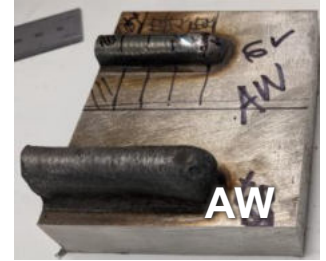

AM: Intermediate phase – heat treatment

Proposed heat treatment (H/T) matrix for IN617						
Phase 1	Objective	Procedure 1	Procedure 2	Procedure 3	Procedure 4	Anticipated output
P1.1	Quantify effects of heat treatment procedure & selection of cooling method.	As deposited	n/a	SEM/EDS	n/a	Observable effects of heat treatment and cooling technique quantified.
		Solution Annealing @ 1177°C	Quenching	SEM/EDS		
		Solution Annealing @ 1177°C	Air cooling	SEM/EDS		
		Solution Annealing @ 1177°C	Oven cooling	SEM/EDS		
Hold (Review SEM/EDS data to inform next step)						
P1.2	Quantify effects of homogenisation + solution annealing procedures.	Homogenisation (1120°C) + Solution Annealing (1160°C)	Cooling method informed by outputs of P1.1	SEM/EDS	n/a	Ideal combination of homogenisation + solution annealing temperatures determined.
		Homogenisation (1120°C) + Solution Annealing (1200°C)		SEM/EDS		
		Homogenisation (1140°C) + Solution Annealing (1160°C)		SEM/EDS		
		Homogenisation (1140°C) + Solution Annealing (1200°C)		SEM/EDS		
Hold (Review SEM/EDS data to inform next step)						
P1.3	Implementation of heat treatment qualification procedure	Procedure informed by P1.2	Stress relieving @ 980 °C	SEM/EDS	SENB (fracture mechanics) on different samples (i.e. LP; LW; AW)	H/T qualification procedure established
Comments/ Clarifications:						
<ul style="list-style-type: none"> - Starting condition: Hot or cold furnace? - 2x each of laser+powder (LP), laser+wire (LW), and arc+wire (AW) AM material samples of dimensions 200mm x 100mm x ~10mm wall thickness will be provided - Sizing requirements: Recommended minimum sample dimensions for heat treatment. - Sizing requirements: Recommended minimum sample dimensions for valid SENB based 1x each of above material samples. 						

AM: Intermediate results – X direction

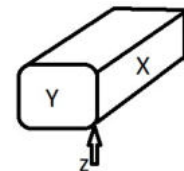

X-Line

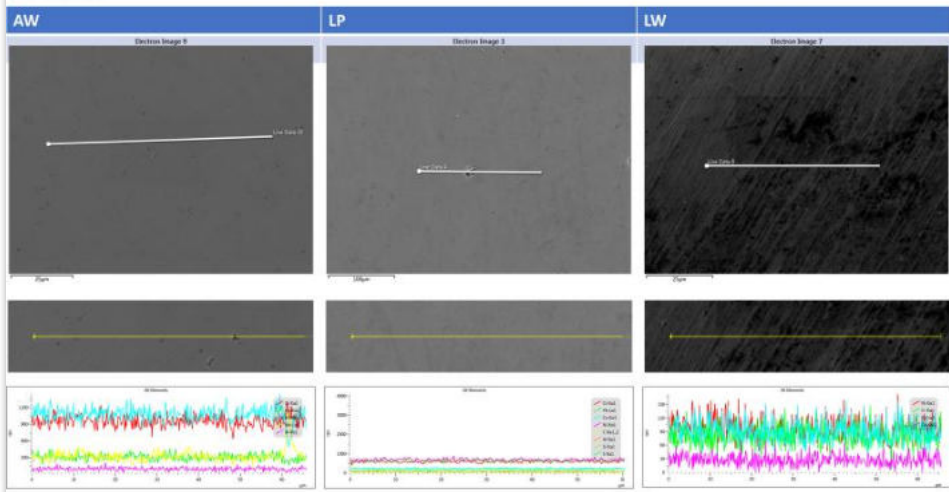

X-Map

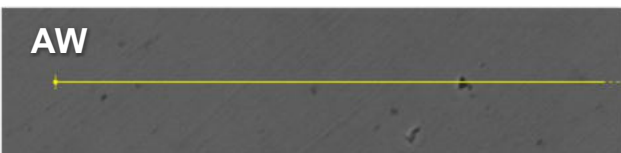
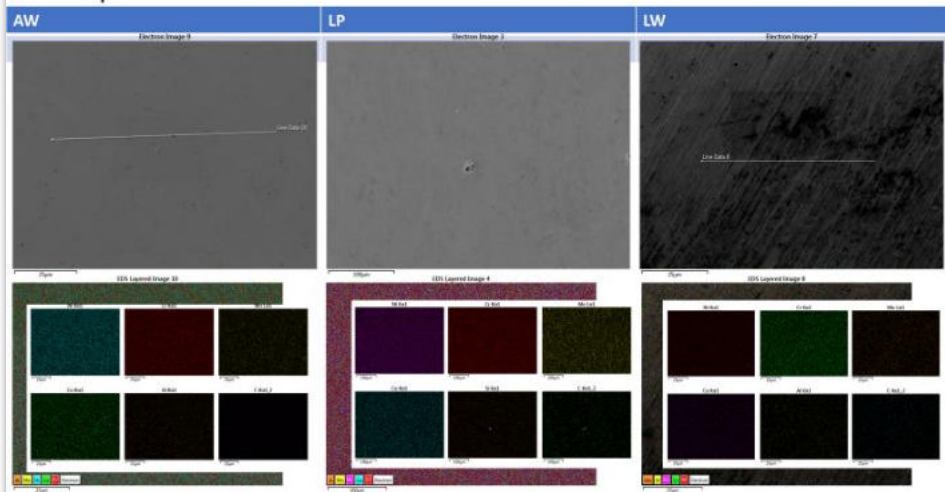

AM: Intermediate results – Y direction

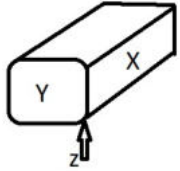

Y-Line

Y-Map

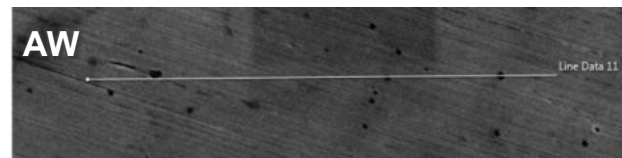
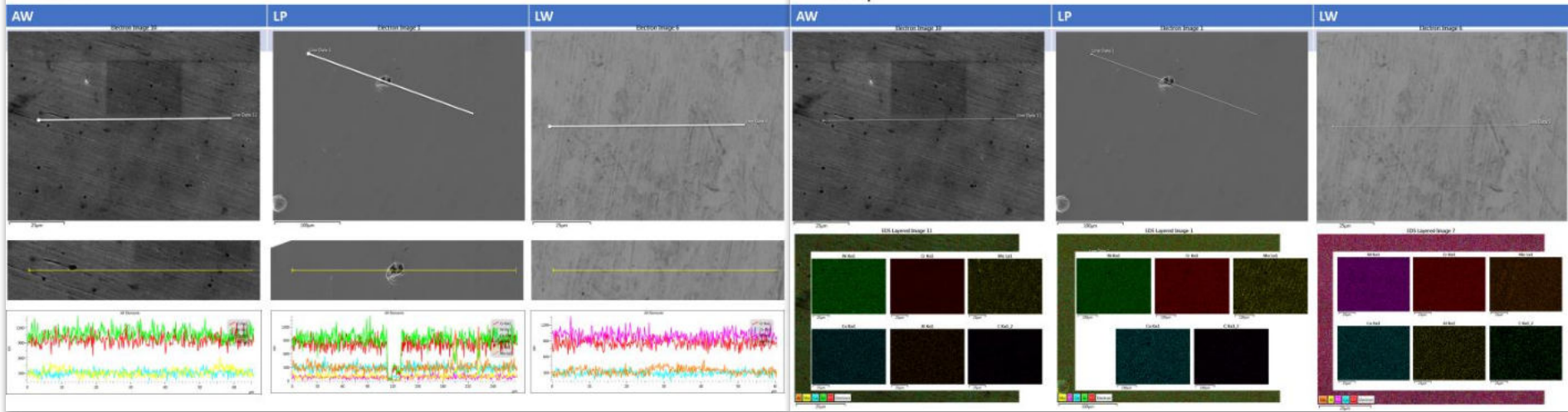

AM: Intermediate results – Z direction

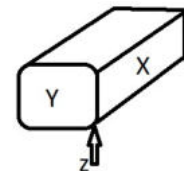

Z-Line

Z-Map

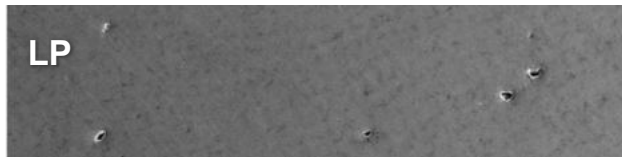
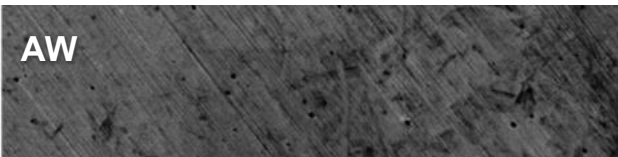
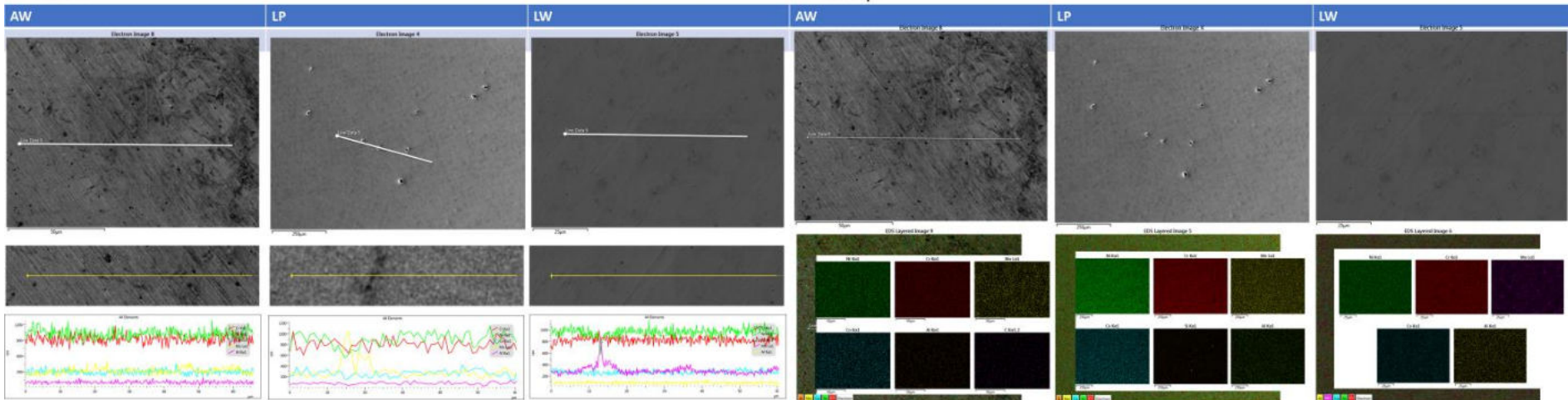

AM: Intermediate phase – acceptance criteria

Small number of
sparsely distributed &
rounded/ spherical
features

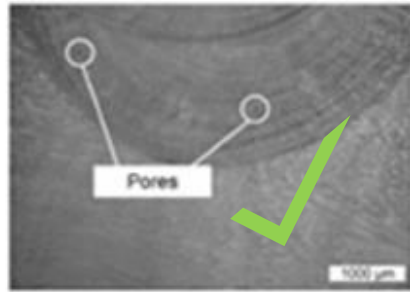

(a)

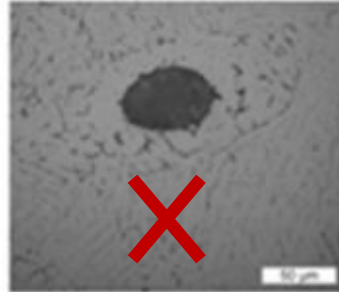

(b)



(c)

Permissible indications
& features, e.g. chain
porosity.



(d)



(e)



(f)

Cracks, irregular
shaped features, lack
of fusion, etc.

SM: Initial & intermediate phase

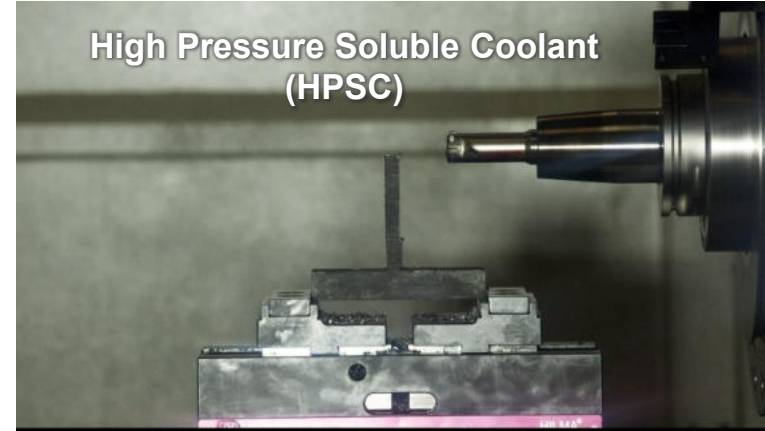

SM: Intermediate results - roughness

Heat Treated Sample Thicknesses

Key	
AW	Arc Wire
LP	Laser Powder
LW	Laser Wire
AB	As Built
AC	Air Cooled
FC	Furnace Cooled
WQ	Water Quenched
HPSC	High Pressure Soluble Coolant
scCO2	Supercritical CO2 with Minimum Quantity Lubrication (MQL)

Sample Name	Thickness (mm)
LP-AC	9.09
LP-FC	8.72
LP-WQ	9.38
LW-AC	6.93
LW-FC	6.34
LW-WQ	5.63

Thinner samples more prone to vibration and deflection during cutting operations

Roughness Values

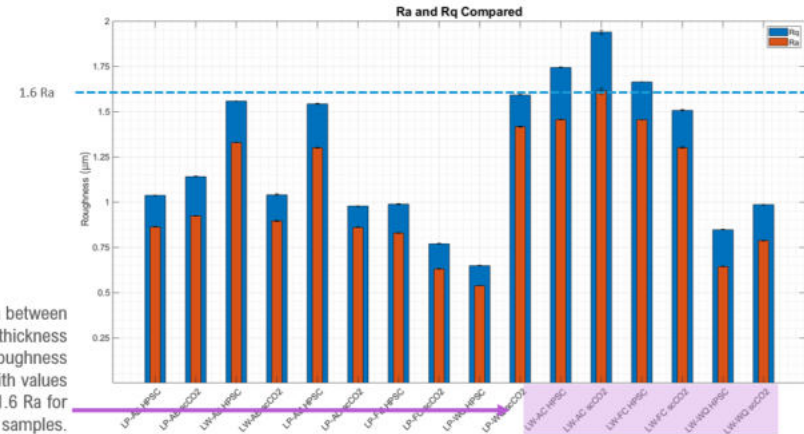

SM: Intermediate results – tool wear

Tool Wear Comparison

Number	Samples Compared		Conclusion
1	LP1 HPSC	LP1 scCO2	No discernible difference
2	LW1 HPSC	LW1 scCO2	No discernible difference
3	LP - AC HPSC	LP - AC scCO2	No discernible difference
4	LP - FC HPSC	LP - FC scCO2	No discernible difference
5	LP - WQ HPSC	LP - WQ scCO2	No discernible difference
6	LW - AC HPSC	LW - AC scCO2	Chips on HPSC Inserts but not on scCO2
7	LW - FC HPSC	LW - FC scCO2	Chips on both cooling strategies
8	LW - WQ HPSC	LW - WQ scCO2	Chips on both cooling strategies

No considerable tool wear was expected due to only conducting 4 finishing passes at 0.1mm axial depth of cut.

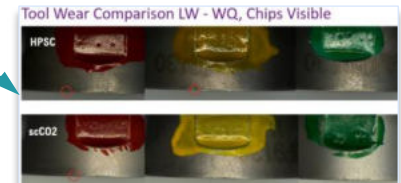
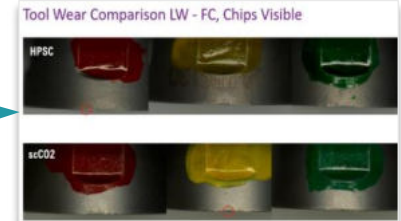
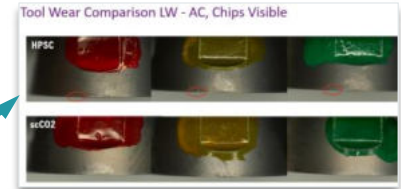
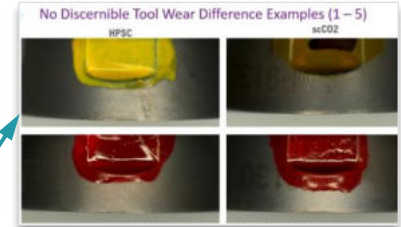

SM: Intermediate results – cutting force

Force Data To Compare

HPSC vs scCO2

Lowest vs highest roughness values

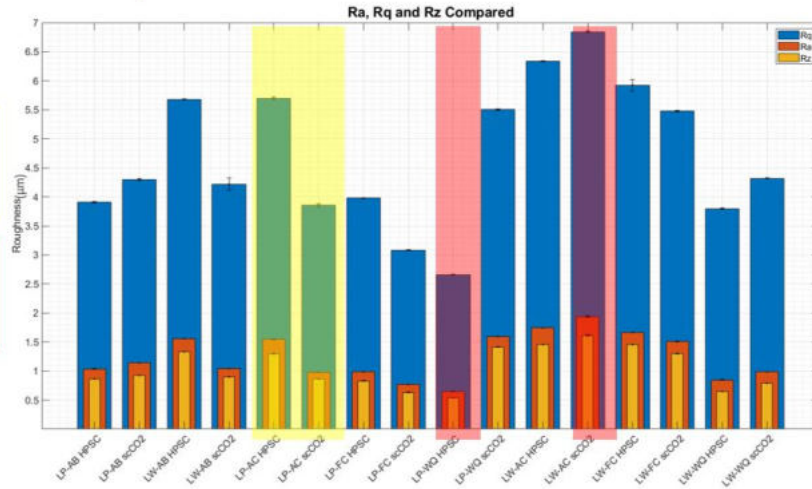

Comparing Largest Delta Between HPSC and scCO2 (LP-AC)

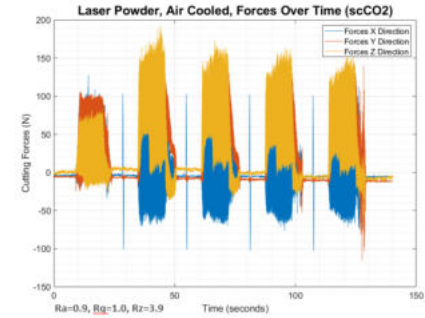
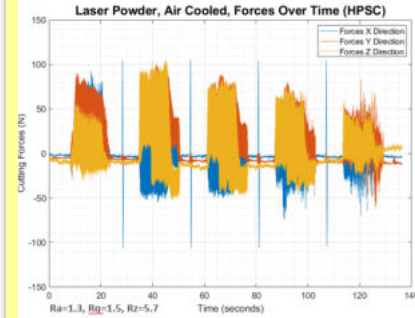

Comparing Lowest and Highest Roughness Values

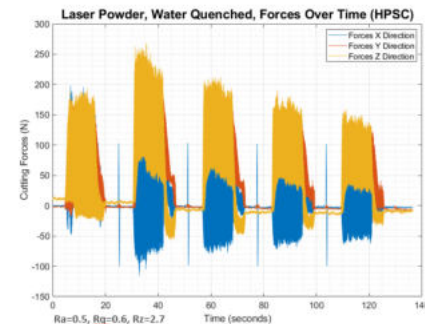
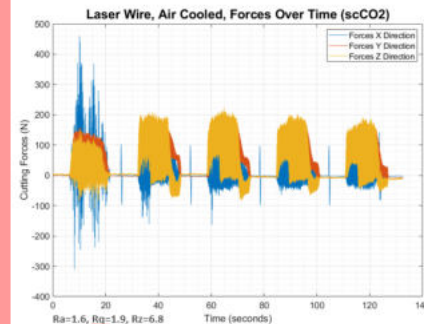

Status/ WIP

SM

- Off the shelf tooling and inserts suitable
- Relatively stable cutting forces with non optimal sections
- Consistent roughness achievable with larger and more dynamically stable samples
- Relative effects of different heat treatment protocols on tool wear rates for DED samples

Advanced machining with the assistance of **supercritical CO₂** and **Minimum Quantity Lubrication (scCO₂+MQL)** will be **used for machining** of claddings for critical components. Current experience with applying advanced coolants in machining will be utilised in this task.

AM

- ~~Qualify heat treatment procedure.~~
- ~~Analyse experimental design space~~
- Stability & repeatability builds.
- Material testing programme.
- Use case definition & implementation

Bulk material manufacturing - hot isostatic pressing (HIP) - Directed Energy Deposition (DED) will be used to **build parts of the established materials.**

An **elevated temperature mechanical testing** will be performed **on samples prepared from the DED parts** and additionally possibly welded joints. **Hot isostatic pressing (HIP)** will be used to **compare and contrast with DED process.**

Thank you for your attention!

The logo for vuje, featuring the word "vuje" in a blue, lowercase, sans-serif font.The logo for mtaE, featuring the letters "mtaE" in a green, lowercase, sans-serif font with a green atomic symbol to the right.The logo for BriVaTech, featuring the text "BriVaTech" in white on a blue rectangular background.The logo for Jacobs, featuring the word "Jacobs" in a bold, black, sans-serif font.The logo for evalion, featuring the word "evalion" in a black, lowercase, sans-serif font with a green circular icon to the right.The logo for the University of Cambridge, featuring a red shield with a white cross and the text "UNIVERSITY OF CAMBRIDGE" below it.The logo for STU, featuring the letters "STU" in a bold, black, sans-serif font with "SLOVENSKÁ TECHNICKÁ UNIVERZITA V BRATISLAVĚ" in smaller text below.

Research on materials for extreme conditions in GEN IV reactors – competencies of Materials Research Laboratory at National Centre for Nuclear Research Poland

Jaroslav Jasinski



NATIONAL
CENTRE
FOR NUCLEAR
RESEARCH
ŚWIERK



This project has received funding from the Euratom H2020 programme NFRP-2019-2020-06 under grant agreement No 945041.

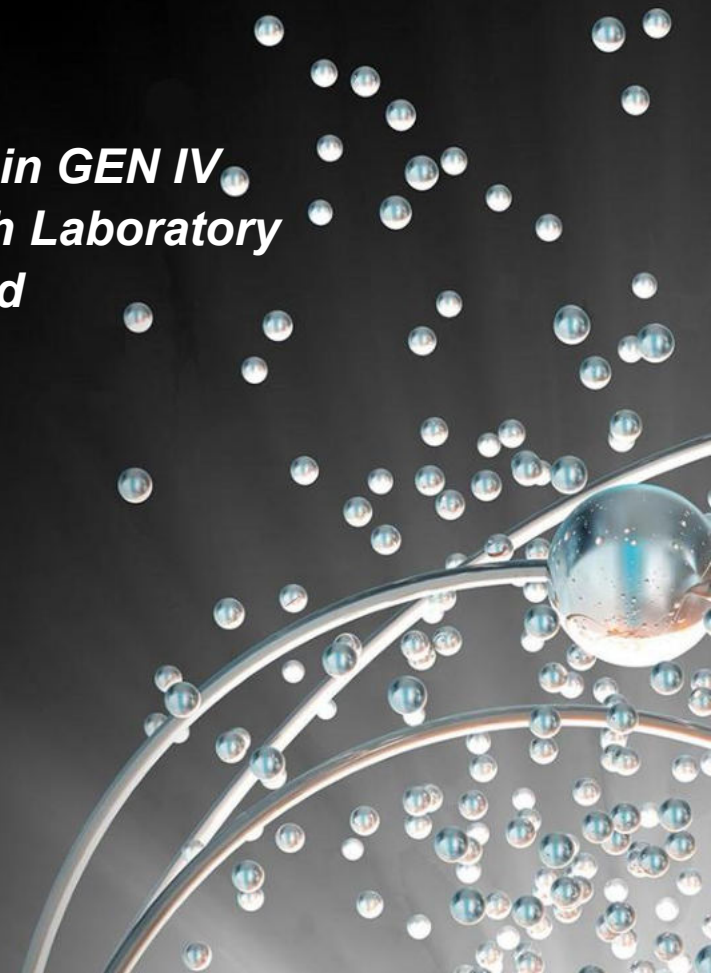

Nuclear Facilities

National Centre for Nuclear Research Poland (NCBJ)



NATIONAL
CENTRE
FOR NUCLEAR
RESEARCH
ŚWIERK

Division of Nuclear
Equipment HITEC



PhDs



ions/year



NCN, NCBR, FNP, RPO

atories
c, FAIR,
sities...

Radioisotope Production
Centre 

Nuclear Equipment
Division (HITEC) 

Science and
Technology Park (PNT)

Scientific-and-Industry Centres



Centre of Excellence in Multifunctional Materials
for Industrial and Medical Applications

Interdisciplinary Division
for Energy Analyses

Nuclear Facilities
Operations
Department



Materials Physics
Department

Materials Research Laboratory

Fundamental Research
Department

Nuclear Equipment &
Technology Department

Department of
Complex Systems



Radioisotope Production
Centre



Nuclear Equipment
Division (HITEC)



Science and
Technology Park (PNT)

National Centre for Nuclear Research Poland (NCBJ)

Location: Otwock / Świerk 35 km from Warsaw

The largest Research Institute in Poland:

- over 1000 Employees,
- the research staff includes 76 Professors & 200 PhDs
- PhD School ca. 80 Students

Research achievements:

- over 500 reviewed papers, with over 16 000 citations/year

Research projects:

- over 117 projects funded by H2020, EURATOM, NCN, NCBR, FNP, RPO
- success rate for EU projects ca. 35%

Scientific cooperation:

- International cooperation with the largest Laboratories in the world JRC, CERN, DESY, Grenoble, JParc, FAIR, Julich, ESS, JINR, T2K, XFEL and many Universities...



NATIONAL
CENTRE
FOR NUCLEAR
RESEARCH
ŚWIERK

Scientific and Industry Centres

NOMATEN

Centre of Excellence in Multifunctional Materials
for Industrial and Medical Applications

Interdisciplinary Division
for Energy Analyses

Nuclear Facilities
Operations
Department



Materials Physics
Department

Materials Research Laboratory

Fundamental Research
Department

Nuclear Equipment &
Technology Department

Department of
Complex Systems



Radioisotope Production
Centre



Nuclear Equipment
Division (HITEC)



Science and
Technology Park (PNT)

Centre of Excellence in Multifunctional Materials
for Industrial and Medical Applications

Interdisciplinary Division
for Energy Analyses



EAR

Research Nuclear Reactor MARIA



MARIA reactor applications:

- production of radioisotopes
- testing of fuel and structural materials for nuclear power sector
- neutron modification of materials
- research in neutron and condensed matter physics
- neutron radiography
- neutron activation analysis
- neutron beams in medicine
- training in the field of reactor physics & technology



Materials Research Laboratory

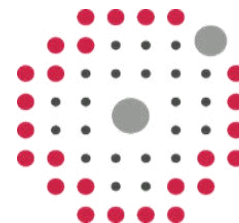

Reaktor
MARIA

- Built in year 1974
- Upgrade in 1992, 2011, and 2017.....**2023 new neutron infrastructure !!!**
- Pool type reactor
- Moderator H₂O, Be
- 30 MW thermal
- Neutron flux
 - thermal: max. $4 \cdot 10^{14}$ n/cm²s
 - fast: max. $2 \cdot 10^{14}$ n/cm²s

Nuclear Facilities Operations Department 

Materials Physics Department



National Centre for Nuclear Research Poland (NCBJ)

Plasma/Ion Beam Technology Division

Nuclear Methods in Solid State Physics Division

Materials Research Laboratory

Materials Research and Testing:

- Non Destructive Testing
- Mechanical properties
- Structure
- Phase analysis
- Chemical composition
- Thermal analysis
- Functional properties
- High temperature corrosion
- Radiation effects

Advanced Materials Manufacturing and Processing:

- ODS steels
- HEA alloys
- Mechanical alloying

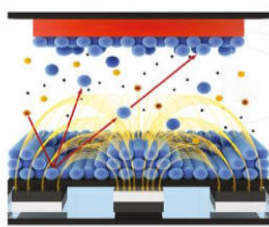

visual-science.com

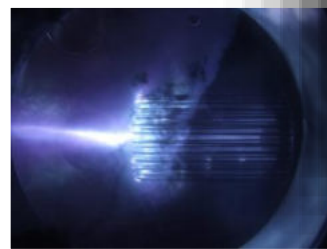

NCBJ Materials Research Laboratory



NATIONAL
CENTRE
FOR NUCLEAR
RESEARCH
ŚWIERK

Competencies

Materials Research Laboratory Divisions

- **Non-Destructive Testing NDT**
- **Mechanical Testing**
- **Structure and Corrosion Research**

NCBJ Materials Research Laboratory – Main Projects and Cooperation

NOMATEN

Centre of Excellence in Multifunctional Materials
for Industrial and Medical Applications

Grant from the FNP MAB PLUS – funding till end of 2023

Grant from European Commission under the TEAMING – funding till 2026

Project funding: total 108 MM PLN / NCBJ funding: 89 MM PLN

The overall goal of the project is to support the research and development in Multifunctional Materials for Industrial and Medical Applications

CoE NOMATEN's research groups:

Complexity in Functional Materials

Materials Characterization

Materials Functional Properties

Structure, Informatics and Function

Novel Radiopharmaceuticals for Medical Purposes

PROJECT HTGR

financed by

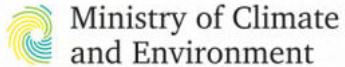

Project HTGR High-Temperature Gas Cooled Reactor

Grant from The Ministry of Science and Higher Education in consultation with The Ministry of Climate and Environment

Project total funding: 60 MM PLN...till 31.01.2024

The overall goal of the project is to prepare conditions for the construction of a research High-Temperature Gas Cooled Reactor in Poland and Development the basic design of such a device at an initial level of detail

Activities in the project

- **Preparation of Materials Research Laboratory MRL** facilities with the necessary accreditations and quality management system required to carry out research work in the materials licensing process for HTGR technology;
- **Testing of materials that can be used for HTGR construction** for compliance with HTGR technology requirements

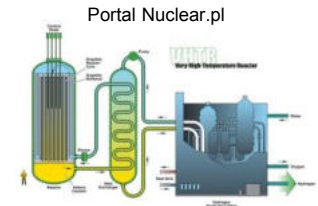

**Funding for MRL
20 MM PLN**

NCBJ Materials Research Laboratory – Non-Destructive Testing NDT Division

Non-Destructive Testing Division is available to perform tests in the scope of:

- Visual Testing method (VT)
- Penetration Testing method (PT)
- Magnetic Particle Testing method (MT)
- Ultrasonic Testing method (UT)
- Eddy Current Testing method (ET)

NDT research infrastructure



ET defectoscope Olympus Nortec 600D

Accredited NDT Testing
Polish Centre for Accreditation
Accreditation number AB 025

Financed by Project HTGR

UT defectoscope Olympus OmniScan MX2



AB 025



VT Flexible Videoendoscope
Mentor Visual IQ - Waygate Technologies



Penetrant method



Magnetic particle method

NCBJ Materials Research Laboratory – Non-Destructive Testing NDT Division



AISI 316L seamless pipes NDT testing for ITER Blanket System components
(First wall panels cooling system) – commissioned by ITER's supplier BIMO TECH

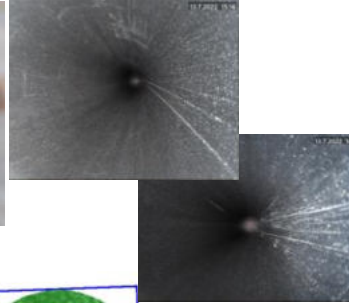

Cold drawing effects depth
Analysed by
VT Flexible
Videoendoscope

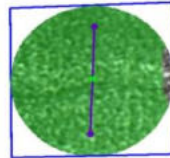

Accredited NDT tests realized according to:

FF9U2X Technical Specification X2CrNiMo17-12-2,
(No. 1.4404) Tube for Blanket Application
Supply of Normal Heat Flux First Wall (FW) Panels for ITER
Blanket System INSPECTION NOTIFICATION

Visual Testing VT – visual inspection outer / inner surface
Ultrasound thickness test UTT – wall thickness
Direct measurements – pipes dimensions



EUROFER 97 after Electron Beam Welding NDT testing
in cooperation with Karlsruhe Institut für Technologie

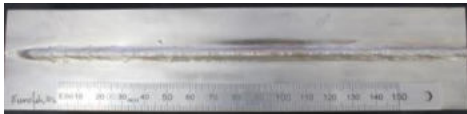

Ultrasound testing UT

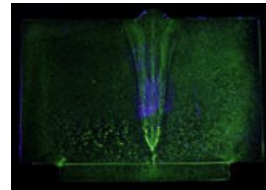

Magnetic particle inspection MT

MARIA Reactor NDT Inspections



Welded joints on secondary
circuit piping with UT, VT, MT

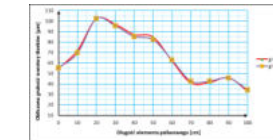

Thickness evaluation of Al_2O_3
layer of the fuel element shells,
Eddy Current Testing

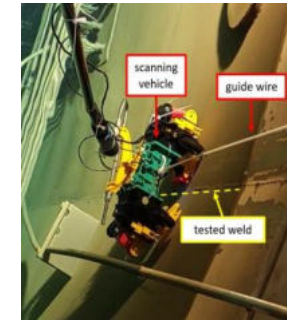

VT, UT reactor pool
weld joints inspection



MARIA reactor weld joints
UT scanning vehicle designed
by Reactor and MRL engineers

NCBJ Materials Research Laboratory – Mechanical Testing Division

Materials hardness testing at macro- / micro- / nanoscale

Semi-automatic Zwick/Roell DuraVision G5 hardness tester



Financed
by Project HTGR

Microhardness tester HV1000



- Load range 10 – 1000 G (HV0.01 – HV1)

Nanohardness tester NanoTest Vantage by Micro Materials Ltd., Wrexham UK



- Berkovich, Vickers, Cube Corner and Conical type indenters available for RT testing
- HT measurements with diamond (up to 450°C) and cBN (up to 750°C) indenter Measurements under **controlled argon atmosphere**
- Humidity cell
- Coupled **Atomic Force Microscope**
- Optical microscope (up to 40x mag.)
- Converts range forces from 0.1 mN to 20 N
- Load or depth-controlled mode
- **Single forces or Load Partial Unload**

- Low-load hardness testing
- Load range 0.3-250 kg
- Brinell HB according to ISO 6506 (ASTM E10) 2.5/5 mm ball
- Vickers HV according to ISO 6507 (ASTM E-92)
- Rockwell HR.. according to ISO 6508 (ASTM E-18) - A,B,C,L,N,T scales

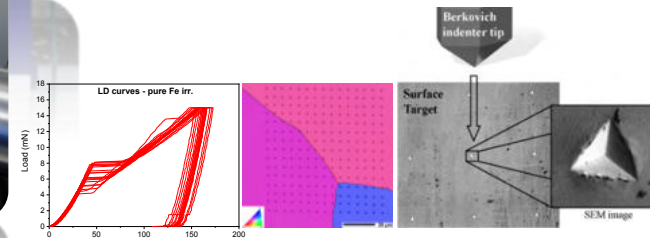

AB 025

NCBJ Materials Research Laboratory – Mechanical Testing Division

Studying effect of ion irradiation and temperature on the properties of Ferritic / Martensitic steels



Samples: Pure Fe; Fe9%Cr; Fe9%Cr-NiSiP, Eurofer 97

Ion irradiation in HZDR up to 8MeV Fe ions, 5 dpa, temp. 300 (and 450°C)

Techniques: Nanoindentation at rT and HT; SEM+FIB/EBSD & TEM; XRD & MD simulations

Results:

- Elastic analysis based on the Hertz revealed that the first pop-in is typically caused by plasticity initiation
- Calculated shear stress is about 3 GPa (theoretical strength)
- Interstitial atoms like C influence pop-in behaviour by blocking preexisting dislocations

Mechanisms to consider:

- Dislocation nucleation at neighboring grain, unlocking pinned by C atoms dislocations at grain boundaries, slip transfer?
- Do we see the impact of crystal orientation?

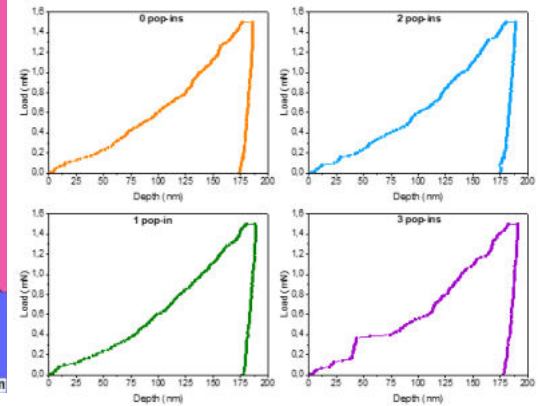
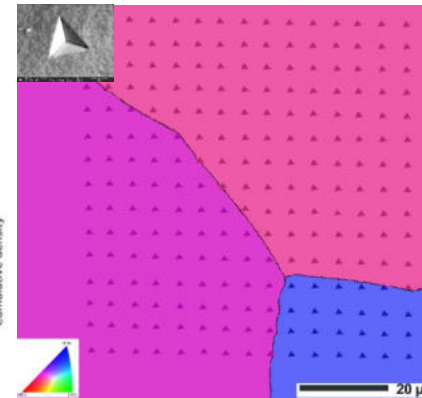
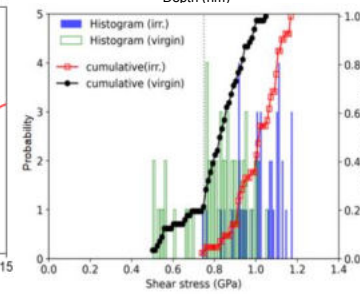
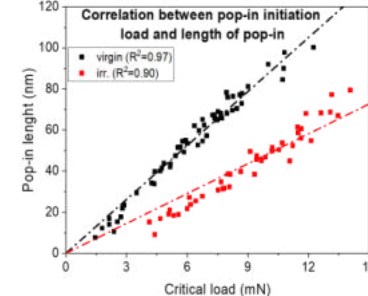
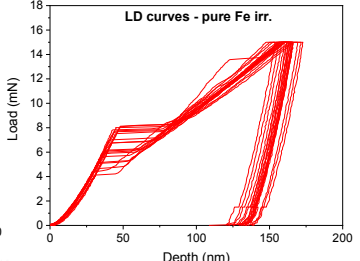
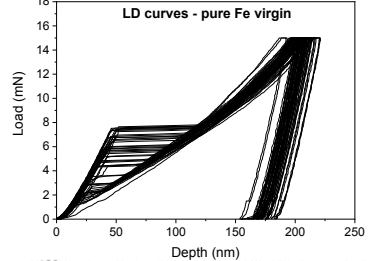
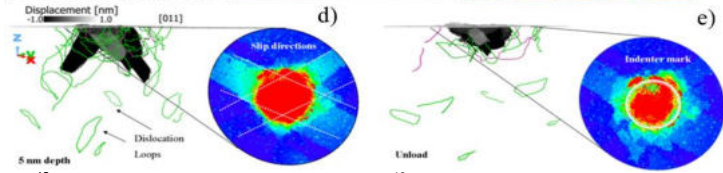
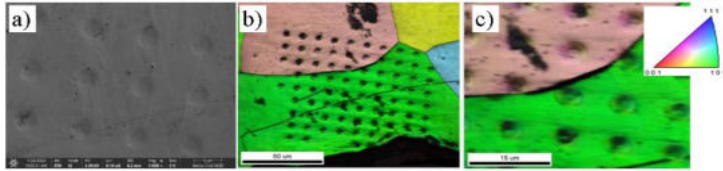

Spherical nanoindentation ($R_i=25 \mu\text{m}$)

NCBJ Materials Research Laboratory – Mechanical Testing Division

Charpy V Impact Testing



Zwick/Roell 450J Pendulum Impact Testing Machine

Standard samples 55x10x10 n2

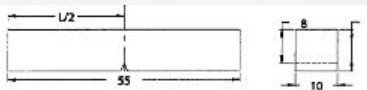

Zwick/Roell 25J Pendulum Impact Testing Machine

- Miniaturized samples
- Instrumented (ISO 14556)

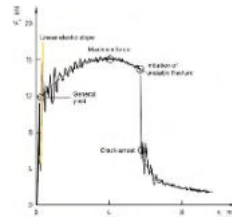

Financed
by Project HTGR

- Impact tests at ambient, low (to -90°C) and elevated temperature (to 300°C)
- 2 mm striker
- According to :
 - ISO 148-1 and ASTM E23 (standard samples)
 - ASTM E2248 (miniaturized charpy V-notch specimens)
 - ISO 14556 (charpy V-notch instrumented test method – miniaturized samples)
- Dynamic fracture toughness K_{Id} (soon...end of 2022)

Accredited Mechanical Testing
Polish Centre for Accreditation
Accreditation number AB 025



AB 025



NCBJ Materials Research Laboratory – Mechanical Testing Division

Static and dynamic strength testing

INSTRON Universal Testing Machine

- Servohydraulic (static/dynamic testing)
- Load capacity ± 100 kN
- Class 0.5 starting from 200 N
- Clip-on extensometers class 0.5
- AlignPRO Alignment Fixture provides full angularity and concentricity adjustment while load is applied to the specimen
- Additional 1kN load cell

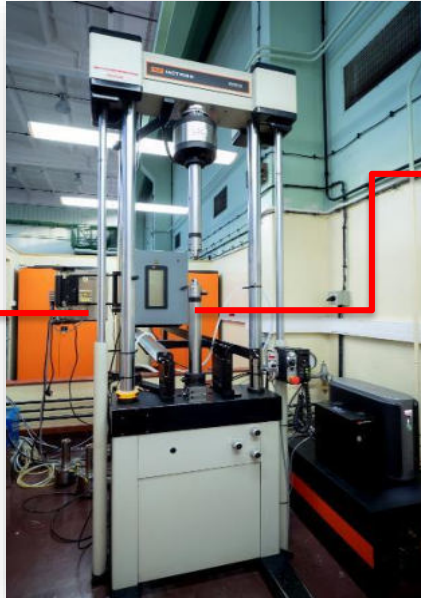

Temperature test chamber with cooling module
Temperature range:
from **-150°C to +350°C**



Three-Heating zone split furnace
Nominal maximum
specimen temperature: **1000°C**

Accredited Mechanical Testing
Polish Centre for Accreditation
Accreditation number AB 025



Mechanical Testing Division realize:

- Tensile testing
- Compression testing
- Fracture toughness testing K_{IC} , critical CTOD, J_{IC} (CT25, SENB)
- Determination of the rate of fatigue crack growth da/dN
- Small Punch Test (SPT)

All tests according to International Standards ISO, ASTM, BS...

SPT Small Punch Test:

Samples: $\phi 3 \times 0,25$ mm discs
Punch: Ball $\phi = 1$ mm
Temperature of test: ambient



Mechanical Testing Division future goals:

- Test samples miniaturization
- Testing of mm samples at HT with non-contact extensometer !!!

NCBJ Materials Research Laboratory – Mechanical Testing Division

Small-scale samples preparation and testing

On-site samples machining by

Currently used machine → Ch ca. 30 years old but functioning v ...otherwise you have to...

NEW WEDM Machining Center
(0.10 mm and 0.05 mm)

- Cuts any metallic conductive material
- **NO-FORCE PROCESS** (machining without mechanical effects and stresses regardless of material structure and hardness)
- **HIGH ACCURACY** machining +/- 2 µm
- **HIGH SURFACE FINISH** (by finishing passages implementation) up to Ra 0.2
- Cost-effective
- Possibility of cutting complex shapes (CAD/CAM inside)
- Possibility of cutting small and thin-walled samples

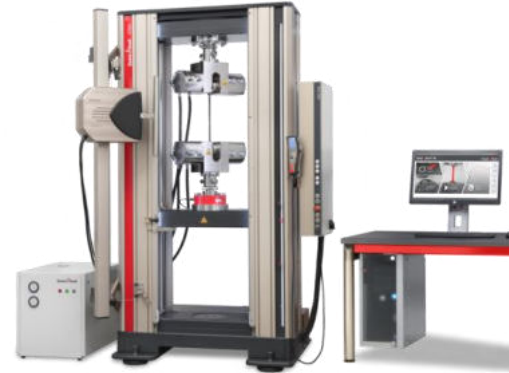

Zwick/Roell Z200 AllroundLine

Miniaturized samples testing

Static testing machine (20 kN)

- Electromechanical
- 0.5 class starting from 20 N
- Furnace up to 1000 °C
- Non-contact extensometer
- DIC software
- Sub-sized tensile specimens
- Alignment Fixture

Financed by Project HTGR

NEW testing machines in the beginning of 2023 !!!

Financed by Project HTGR

Dynamic testing machine (± 10-15 kN)

- Resonance system
- CT1/2", CT1/4" and SENB
- <100 mm samples
- Alignment Fixture



GF Charmilles CUT E350 WEDM Machining Center



Zwick/Roell Vibrophore 25

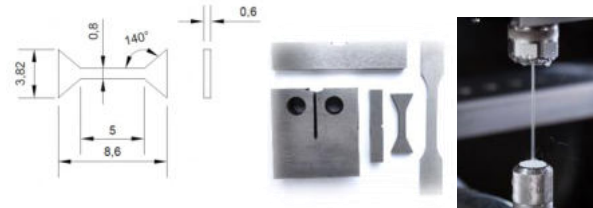

NCBJ Materials Research Laboratory – Structure and Corrosion Research Division

Metallographic samples preparation and microstructure analysis

Metallographic sample preparation section

- Cut-off machines (precision cutting)
- Manual or automatic grinder / polisher
- Manual or automatic, electrochemical (0-100V) and vibropolishing (60 - 120 Hz)
- Electrochemical polishing and etching (0-25V) / possibility of electrolytic polishing in cool temperature mode
- Hot Mounting Press



QATM Opal 410 press



QATM Saphir Vibro polisher



Struers – LectroPol electrochemical polishing / etching system



QATM Saphir 250 M2 automatic grinder / polisher



Microstructure analysis – light microscopy

- Leica DM IL Inverted Metallurgical Microscope
- Olympus BX53M Metallurgical Microscope
- ✓ Light microscopy contrast methods such as brightfield BF, darkfield DF, polarized light POL, and differential interference contrast DIC
- ✓ Olympus licensed software for determining average grain size according to international standards (i.a. ASTM E112, ISO 643) and phase analysis



Olympus BX53M
Metallurgical Microscope

NCBJ Materials Research Laboratory – Structure and Corrosion Research Division

Samples preparation and microstructure analysis

SEM microscope Helios 5 UX DualBeam (Thermo Fisher Scientific)

The Extreme High Resolution (XHR) Field Emission Scanning Electron Microscope (FE SEM) equipped with:

- FIB (Focused Ion Beam) technology
- EDS (Energy Dispersive X-ray Spectroscopy)
- EBSD (Electron Backscatter Diffraction)

Ion Beam Precision Etching Coating System

The PECS II (Gatan) is used to polish surfaces and remove without damage with two broad argon beams. This method is powerful for producing high-quality samples:

- for scanning electron microscope (SEM) observations
- for SEM imaging and EDS mapping
- for EBSD analysis,
- for STEM, TEM observation etc.

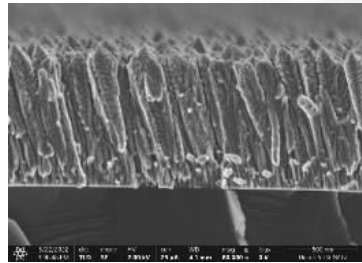

High resolution SEM imaging
Acceleration voltage: 350V – 30kV
Resolution: 0.6 nm (2 - 15kV), 0.7 nm (1 kV)
Detectors: ETD, TLD, ICD, MD, ICE



Coming soon !

TEM with STEM, HAADF, EDS, BEI, BF and ABF detectors
Equipped with in-situ tensile and HT annealing up to 1000°C holders

Illustrative image



Confidential !!!
Procurement procedure
in progress

Expected installation June 2023

NCBJ Materials Research Laboratory – Structure and Corrosion Research Division

X-ray diffraction phase analysis

Bruker D8 ADVANCE with DAVINCI

- equipped with a sealed Cu X-Ray tube, TWIN-TWIN optics and LYNXEYE XE-T strip detector
- Cu radiation, $\lambda_{K\alpha 1} = 1.540562 \text{ \AA}$
- Energy Resolution < 380 eV at 8 keV
- B-B/GID geometries

High-temperature stage - Anton Paar HTK 1200 N

- temperature up to 1200°C
- operates Under Vacuum or Selected Gas Environment
- specimen Stage with Rotation (Rocking)

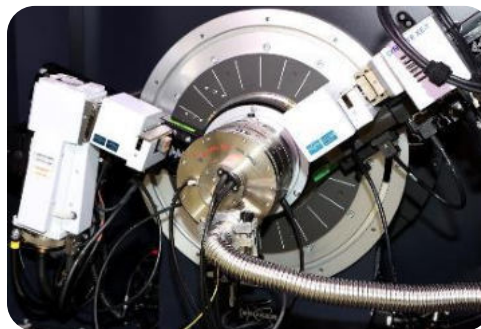
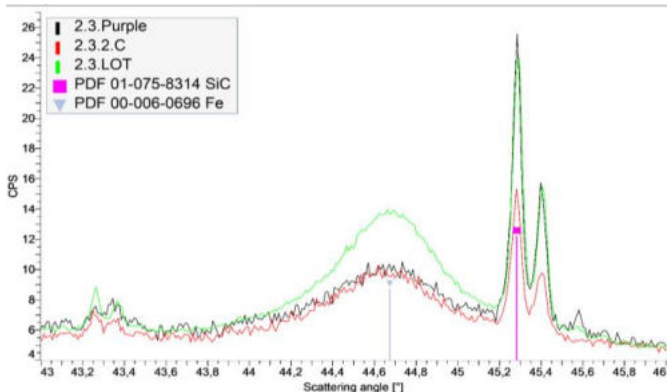

NCBJ Materials Research Laboratory – Structure and Corrosion Research Division

Spectroscopic phase and chemical composition analysis

Raman Spectroscopy

Research Features

- Obtaining qualitative to semi-quantitative information on material phase composition (Raman imaging)
- Determination of stress distribution
- Examination of phase transition and corrosion of materials
- Observations of structural changes after ion implantation - defects type and amount determination



High resolution SEM imaging
Acceleration voltage: 350V – 30kV
Resolution: 0.6 nm (2 - 15kV), 0.7 nm (1 kV)
Detectors: ETD, TLD, ICD, MD, ICE



Optical microscope:
Zeiss Neofluar objectives
magnification x10, x50, x100



High temperature stage
(up to 1000 C)



WiTec Alpha 300R Raman Spectrometer

Spark OES Spectroscopy

Bruker
Q4 TASMAN Series 2



Accreditation procedure in progress !!!

Research Features:

- 4 Bases Fe, Al, Ni, Ti
- Digital Spark Source delivers improved analytical precision and shorter time-to-result.
- Dual optics concept with robust Paschen Runge mount, multi-chip systems with temperature stabilization

Effect of temperature and radiation damage on corrosion kinetics of zirconium alloys

Raman Imaging – ZrO₂ scale mapping

Motivation

- Determining corrosion kinetics for pure Zr, E110, Zircalloy-2
- Improvement of hydrogen pickup resistance
- Influence of irradiation on corrosion properties
- Stress correlation with tetragonal phase percentage and distribution

T-ZrO₂ percentage calculation:

$$\%T_{ZrO_2} = \frac{I(T_1)}{I(M_1) + I(T_1) + I(M_2)}$$

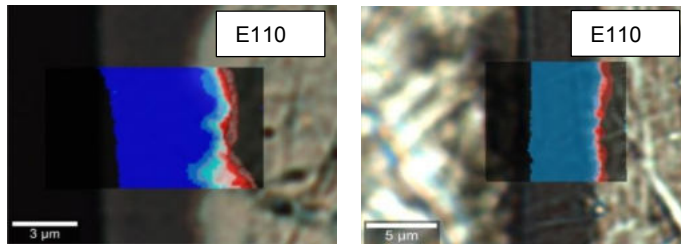
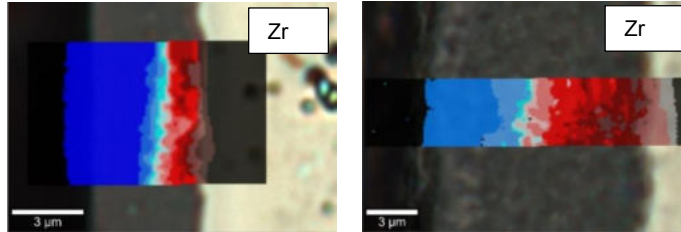
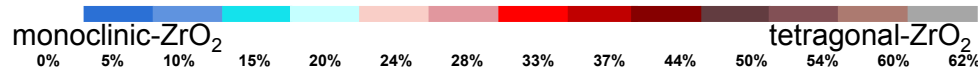

In-situ HT Raman tests

Impact of external load on the T and M phases

SEM-EDS line profile analysis

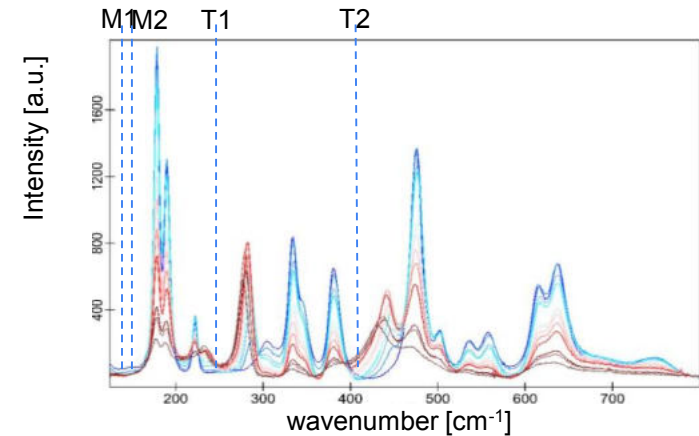
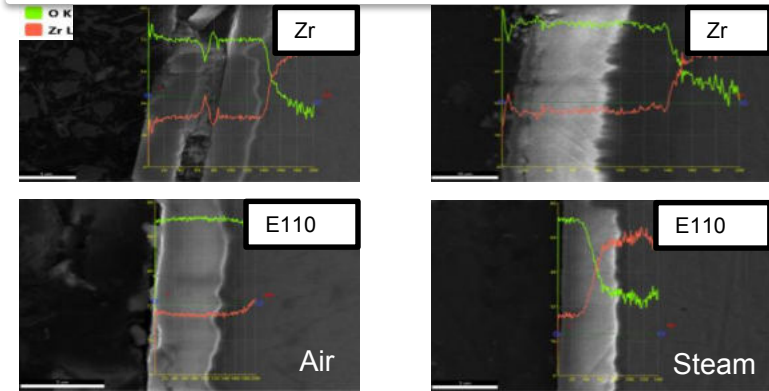

NCBJ Materials Research Laboratory – Structure and Corrosion Research Division

Spectroscopic phase and chemical composition analysis

Coming soon...by the end of 2022

ICP-MS integrated with Laser Ablation LA and LIBS spectrometer

Analytik Jena Plasma Quant MS Q <-> Applied Spectra J200 LA system with LIBS

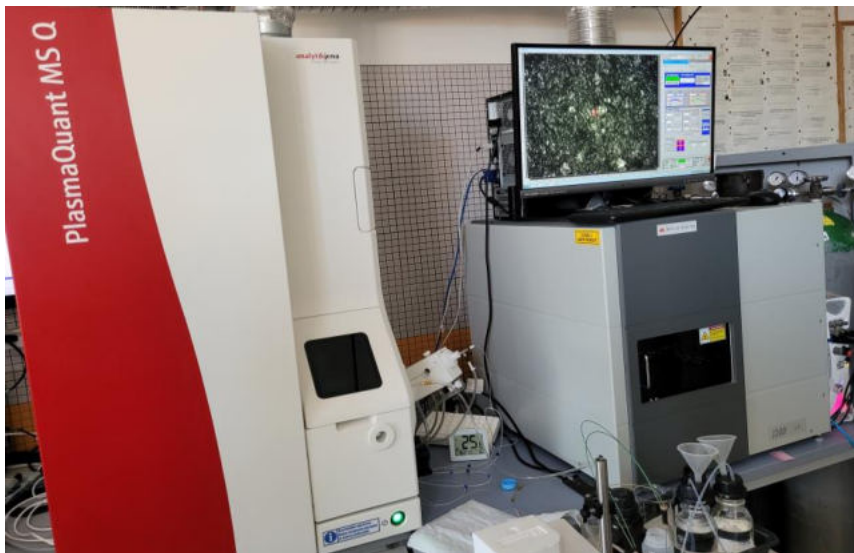

Financed
by Project HTGR

Chemical analysis at .ppm and .ppb level of high purity graphite in accordance with IAEA regulations

Other research plans:

- solid samples impurities analysis
- C,H,O,N detection in materials (LIBS)
- MARIA reactor water analysis

TOYO TANSO

Element	Content			Measurement Method	Element	Content			Measurement Method
	Ultra High Purity Graphite	High Purity Graphite	Regular Graphite			Ultra High Purity Graphite	High Purity Graphite	Regular Graphite	
Li	<0.001	<0.001	<0.03	ICP-MS	V	<0.001	0.018	40	ICP-MS
B	0.10	0.15	3	ICP-MS	Cr	<0.004	0.006	<0.3	ICP-MS
Na	<0.002	<0.002	<0.5	ICP-MS	Mn	<0.001	<0.001	<0.3	ICP-MS
Mg	<0.001	0.004	0.2	ICP-MS	Pb	<0.02	0.06	36	ICP-MS
Al	<0.001	0.012	14	ICP-MS	Cu	<0.001	<0.001	<0.3	ICP-MS
Si	<0.1	<0.1	2	UV	Ni	<0.001	0.008	4	ICP-MS
K	<0.03	0.04	2	FLAAS	Cd	<0.002	<0.002	<1	ICP-MS
Ca	<0.01	0.06	6	FLAAS	Zn	<0.002	<0.002	<0.6	ICP-MS
Ti	<0.001	<0.001	33	ICP-MS	Pb	<0.001	<0.001	<1	ICP-MS

Spark OES Spectroscopy



Bruker
Q4 TASMAN Series 2



Accreditation procedure in progress !!!

Research Features:

- 4 Bases Fe, Al, Ni, Ti
- Digital Spark Source delivers improved analytical precision and shorter time-to-result.
- Dual optics concept with robust Paschen Runge mount, multi-chip systems with temperature stabilization

NCBJ Materials Research Laboratory



Research Activities in SafeG Project



WP2 – Advanced Materials and Technologies

NCBJ Materials Research Laboratory – Research Activities in SafeG Project



WP2 – Advanced Materials and Technologies

GFR demonstrator ALLEGRO concept

Project main objectives in connection with advanced materials and technologies:

- **Strengthen safety of the GFR demonstrator ALLEGRO** through the use of innovative technologies, materials and system
- **Strengthen the safety of key reactor components** by reviewing obsolete materials, and selecting innovative material options
- **To review the GFR reference options in materials and technologies**

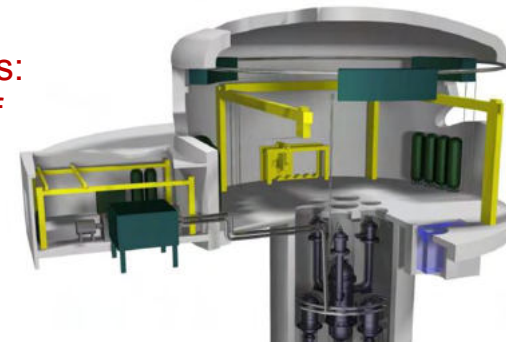

WP2 Deliverables

- D2.1 Innovative cladding materials testing (MTA-EK, M24)
- D2.2 ALLEGRO Core support plate (UJV, M36)
- D2.3 DHR Heat Exchanger (UJV, M36)
- D2.4 Main Heat Exchanger (CVR, M36)
- D2.5 Structural materials testing in media (CVR, M45)
- **D2.6 Advanced manufacturing processes and materials (NCBJ, M45)**

NCBJ Materials Research Laboratory – Research Activities in SafeG Project

FeCrAl-ODS steels manufacturing – background

FeCrAl-ODS steels are considered one of the most promising candidates for cladding materials for the application in Generation IV nuclear reactors

FeCrAl steels have been extensively studied, however, there is **still little investigation reported on FeCrAl-ODS steels with Y_2O_3 , Ti, V additions** and their manufacturing processes, microstructure, mechanical properties, high-temperature corrosion kinetics and radiation resistance

There are also limited data available on the multiscale structure and mechanical properties of FeCrAl-ODS steels with different contents of Y_2O_3 , Ti, V, upon long-term thermal ageing for a period of time comparable to the refuelling cycle of Generation IV reactors

Vanadium and Titanium additives

Vanadium addition improves strength properties (plasticity, hardness) and in combination with Ti, it helps in increasing the energy of atomic bonds.

Titanium has a very high tendency to form stable carbides. As an alloying additive in steel, it helps in increasing the strength. For these reasons, it is most often used as an alloying additive in steels where it prevents intergranular fracture together with carbon - titanium carbide, which improves mechanical properties, and refines the grain structure.

The addition of Y_2O_3 , Ti, and V oxides to the Fe-Cr-Al matrix leads to:

Fine grain homogenous structure and grain growth blockers and stabilizers at high temperatures

Defects in the matrix (dislocations, oxide/carbide – matrix interfaces) > outstanding mechanical properties

Mitigation of thermal ageing embrittlement

Impede or delay the formation of the Cr-enriched α' phase by affecting the diffusion path during the thermal ageing process)

Why Vanadium and Titanium ?

Selected Chemical composition

FeCrAl-ODS chemical composition						
	Fe	Cr	Al	Y_2O_3	Ti	V
M1	Bal.	9	5	0.3	0.5	-
M2	Bal.	9	5	0.3	1	-
M3	Bal.	12	5	0.3	0.5	-
M4	Bal.	12	5	0.3	1	-
M5	Bal.	9	5	0.3	0.5	0.5
M6	Bal.	9	5	0.3	1	0.5
M7	Bal.	12	5	0.3	0.5	0.5
M8	Bal.	12	5	0.3	1	0.5

Literature review 2020 / 2021

Peng Dou, Wei Sang, Akihiko, *Effects of the contents of Al, Ti, W and Y_2O_3 on long-term thermal ageing behavior of 15Cr ODS ferritic steels*, Journal of Nuclear Materials 2020

K. Lipkina et. al. *A study of the oxidation behaviour of FeCrAl-ODS in air and steam environments up to 1400 C*, Journal of Nuclear Materials 2020

S. Mirzababaei, M. Ghayoor, R.P. Doyle, S. Pasebani, *In-situ manufacturing of ODS FeCrAlY alloy via laser powder bed fusion*, Materials Letters 2021

NCBJ Materials Research Laboratory – Research Activities in SafeG Project

FeCrAl-ODS steels manufacturing – Research Goal and Manufacturing Roadmap

Research goal:

- Preparation of the FeCrAl matrix with oxides nanoparticles in order to reduce the effects of ageing, and brittleness at high temperature
- Preparation of a densely dispersed alloy to delay the formation of a Cr-enriched α' phase
- Improvement of mechanical properties by strengthening with fine dispersion oxides
- The formation of a protective oxide layer on the surface

I. / II. Powder Mechanical Alloying

Manufacturing Roadmap



Powder mixing in Ar-atmosphere glovebox

Milling balls and jar: WC



Milling in Planetary ball mill
Rotation speed: 250 rpm
Milling time: 10 / 20 / 30 / 40 h
BPR: 5:1



Sample preparation (grinding, polishing, electropolishing)

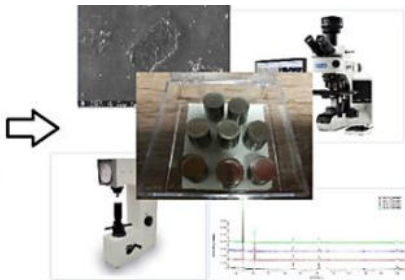

Sample evaluation (density, light microscope, SEM, XRD, hardness)
In future also TEM, other mechanical tests



Annealing of samples
Temperature: 1050 degree C
Time: 12 h

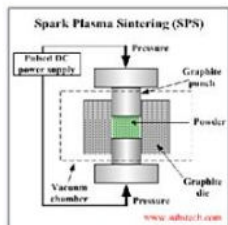

Sintering via SPS
Pressure: 40 / 50 MPa
Time: 10 min
Temperature: 950 degree C

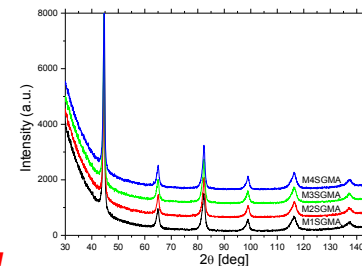
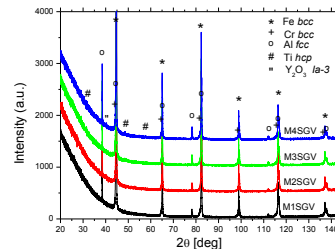
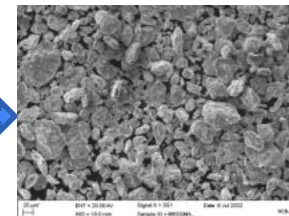
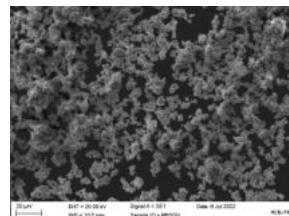

III. Spark Plasma Sintering

Temp = 1050°C
Time = 10 min
p = 40 MPa



NCBJ Materials Research Laboratory – Research Activities in SafeG Project

Powder Analysis and Mechanical Alloying

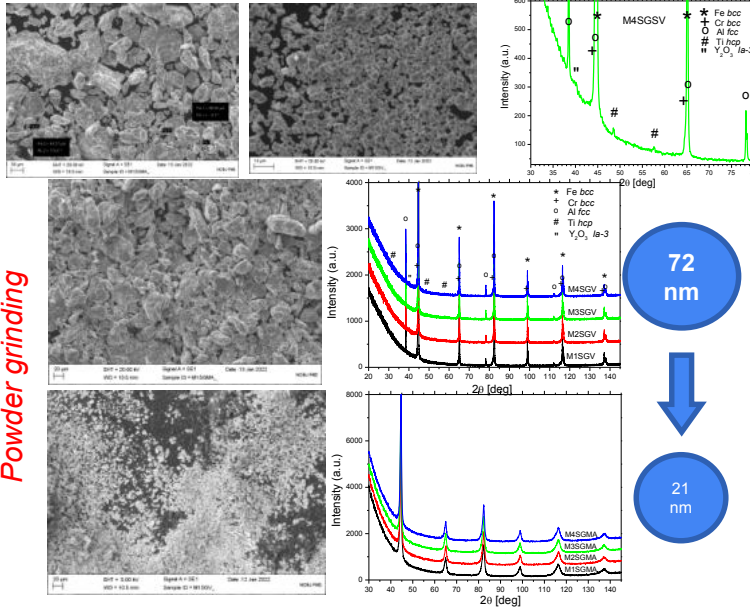

Powder grinding

SPS Process

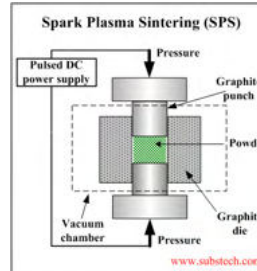
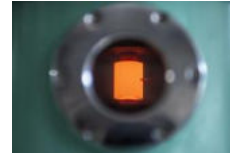

Density after SPS

	M1 Bal. Fe 9Cr 5Al 0.3Y2O3 0.5Ti	M2 Bal. Fe 9Cr 5Al 0.3Y2O3	M3 Bal. Fe 12Cr-5Al 0.3Y2O3 0.5Ti	M4 Bal. Fe 12Cr-5Al 0.3Y2O3 1Ti	M5 Bal. Fe 9Cr 5Al 0.3Y2O3 0.5Ti V0.5	M6 Bal. Fe 9Cr 5Al 0.3Y2O3 1Ti V0.5	M7 Bal. Fe 12Cr-5Al 0.3Y2O3 0.5Ti V0.5	M8 Bal. Fe 12Cr-5Al 0.3Y2O3 1Ti V0.5
	7,1	7,2	5,7	7,2	7,2	5,9	7,2	7,2
	7,1	7,2	5,7	7,1	7,2	5,6	7,2	7,2
	7,1	7,2	5,5	7,1	7,2	5,7	7,2	7,2
Arithmetic average	7,1	7,2	5,6	7,2	7,2	5,8	7,2	7,2
% Fe density (7,8 g/cm3)	91	92	72	92	92	74	92	92



Samples dimensions: ϕ 25 x 10 mm

Conclusions

- Through the mechanical alloying process, we obtained a homogeneous distribution of oxide particles in an ODS steel matrix.
- The diffraction lines are shifted to lower values of the diffraction angle, which proves the formation of a solid solution.
- The density of Fe is 7.88 g / cm³, which is the highest composition, and compared to the density of the samples, translates into about 92% of Fe density in the case of a ODS solid samples

NCBJ Materials Research Laboratory – Research Activities in SafeG Project

FeCrAl-ODS steels manufacturing – Research Goal and Manufacturing Roadmap

Manufacturing Roadmap



Powder mixing in Ar-atmosphere glovebox
Sample: Cr1Co1Fe1Ni1
PCA: n-heptane
Milling balls and jar: WC



Milling in Planetary ball mill
Rotation speed: 250 rpm
Milling time: 10 / 20 / 30 / 40 h
BPR: 5:1

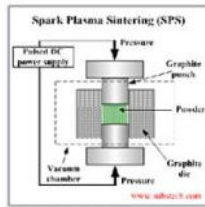

Sintering via SPS
Pressure: 40 / 50 MPa
Time: 10 min
Temperature: 950 degree C



Sample preparation (grinding, polishing, electropolishing)



Sample evaluation (density, light microscope, SEM, XRD, hardness)
In future also TEM, other mechanical tests



Annealing of samples
Temperature: 1050 degree C
Time: 12 h

IV. Sample preparation

WEDM cutting



Electropolishing and Etching



V. Mechanical properties, structure and phase analysis

LM / SEM / EBSD observation

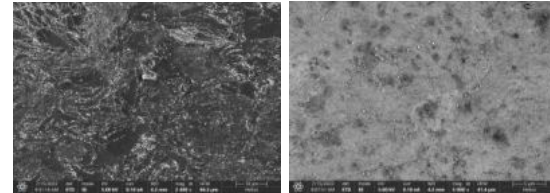

XRD – ongoing

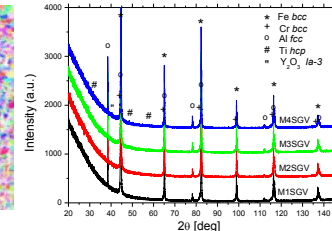
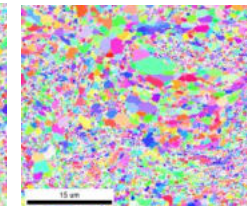
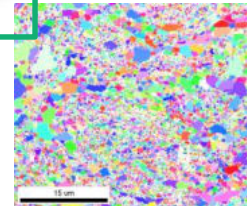

VI. Heat treatment / Annealing

Temperature – 950 to 1000°C
Time – 1 h
Atmosphere – Argon
Vacuum
Cooling – slow cooling in air



Vacuum
Furnace

NCBJ Materials Research Laboratory – Research Activities in SafeG Project

Structure and phase analysis SEM

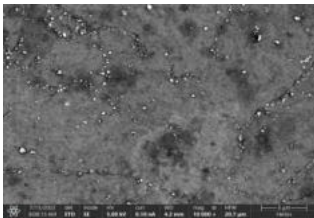
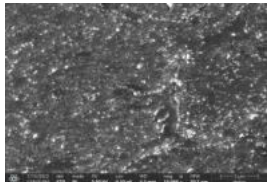
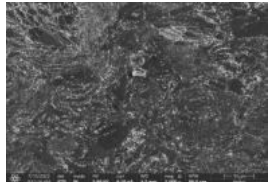

SEM/EBSD analysis

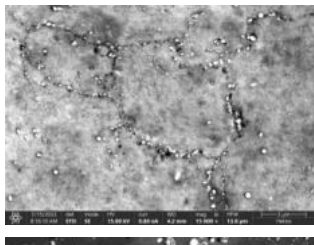
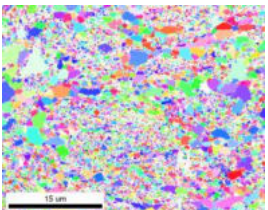
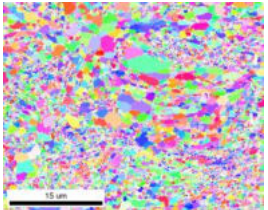

SEM/EDS mapping

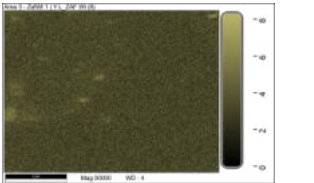
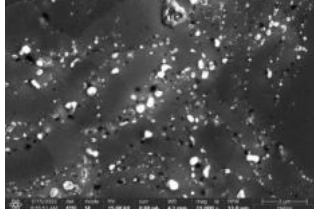
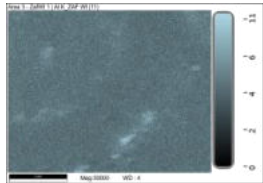
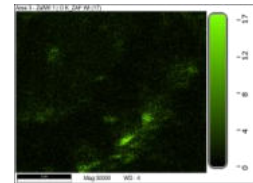
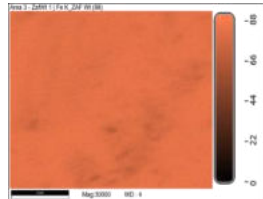
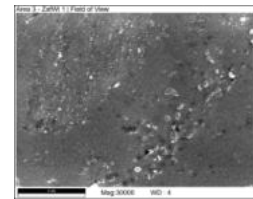

Vickers Hardness HV0.5 after SPS

HV 0.5	M1 Bal. Fe 9Cr 5Al 0.3Y2O3 0.5Ti	M2 Bal. Fe 9Cr 5Al 0.3Y2O3 1Ti	M3 Bal. Fe 12Cr 5Al 0.3Y2O3 0.5Ti	M4 Bal. Fe 12Cr 5Al 0.3Y2O3 1Ti	M5 Bal. Fe 9Cr 5Al 0.3Y2O3 0.5Ti V0.5	M6 Bal. Fe 9Cr 5Al 0.3Y2O3 1Ti V0.5	M7 Bal. Fe 12Cr 5Al 0.3Y2O3 0.5Ti V0.5	M8 Bal. Fe 12Cr 5Al 0.3Y2O3 1Ti V0.5
	356	339	382	286	253	350	297	323
	348	350	388	280	285	365	294	330
	386	380	366	299	271	318	301	327
	383	345	372	287	263	358	302	301
	380	301	371	291	263	360	307	319
Arithmetic average	370.6	343	375.8	288.6	267	350.2	300.2	320

Mechanical properties

Nanohardness surface / matrix

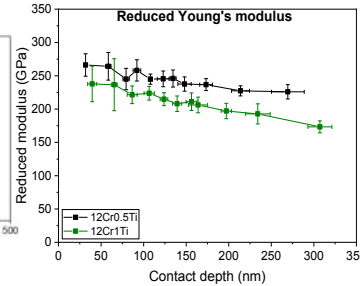
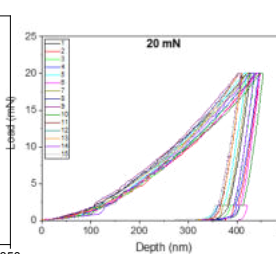
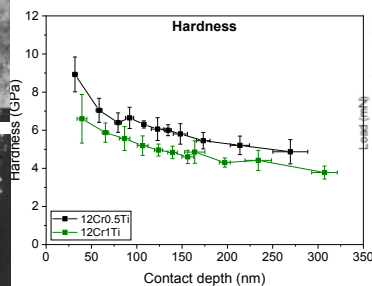

Conclusions

- The size of particles, dispersion morphology and chemical compositions of precipitates formed in the FeCrAlY ODS steels were determined to ascertain the underlying mechanisms of the effects of the various contents of Cr, V, Ti
- Different oxide particles dispersion and morphology have been studied by SEM/EDS/EBSD
- Fine and homogenous FeCrAlY + V, Ti matrix analysis is foundation for future design and optimization of ODS steel in order to investigate the effects of the Cr, Ti, V contents on the structure behaviour after different variants of heat treatment and thermal ageing ...HT / Ageing yet to realize!

NCBJ Materials Research Laboratory – Research Activities in SafeG Project



WP2 Advanced materials and technologies – Future plans and research

- **Sintering of the FeCrAl ODS steels** (12 compositions to be evaluated and judged from the point of GFR and HTGR applications)
- **Verification and complex analysis of other ODS steels manufacturing techniques** (HIP / Arc melting, Hot Extrusion etc.)
- **Investigating the radiation resistance of FeCrAl ODS steels** produced with different techniques and various technological parameters
- **Investigating of annealing and ageing effects on Al-added high – Cr ODS steels**
- **Mechanical testing of FeCrAl ODS steels at high temperatures** (miniaturised samples)
- **Thermal characterization and preliminary high-temperature corrosion tests of FeCrAl ODS steels** (TG,DTA,DSC,DIL)
- **Complex microstructural characterization of FeCrAl ODS steels** (SEM/EBSD/FIB and TEM/STEM)
- **Protective thin layers formation** on ODS steels (PVD, CVD, Sol-gel)
- **Comparison with other ODS steels** (FeCrAl vs NiCoFe)

NCBJ Materials Research Laboratory



Other Materials Research Activities

NCBJ Materials Research Laboratory – Other Materials Research Activities

Evaluation of alternative refractory oxides as a strengthening particles in ODS RAF⁺ steels

Oxide Dispersion Strengthening

Gen IV?

Addition of refractory oxides to the matrix should lead to:

- Structure refinement → increment of volume of grain boundaries
- Stabilization of grain structure at high temperature → excellent creep strength, high mechanical properties at HT
- High density of point defects sinks (boundaries, dislocations, oxide-matrix interfaces) → outstanding mechanical properties & radiation resistance

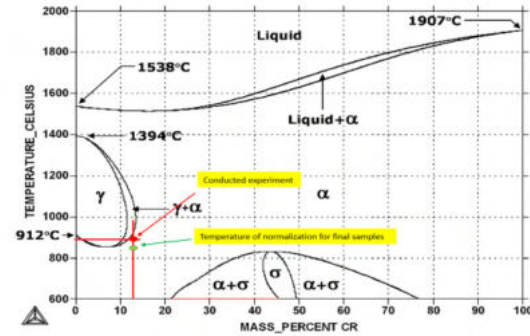

- ODS with yttria Y_2O_3 (as a reference)
- ODS with alumina Al_2O_3 (alternative - heat of formation = 1678.2kJ/mol at 25°C)
- ODS with zirconia ZrO_2 (alternative - heat of formation = 1100.6kJ/mol at 25°C)
- Non-ODS steel (as a reference)

Fabrication process

Mechanical Alloying

Spark Plasma Sintering



+

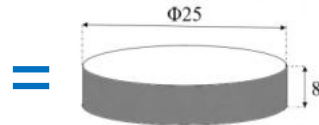

Density about 98.5%

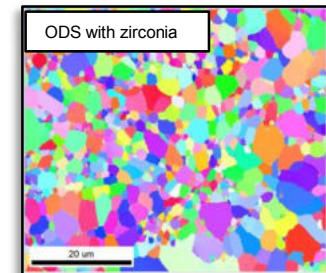
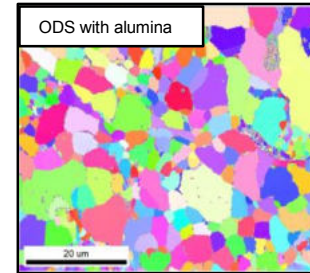

Conclusions and next steps:

- Successful production of new ODS RAF steels
- Density close to theoretical value
- Annealing / Normalizing at different conditions should solve problem of homogeneity

Project funded by NCN, Preludium call – 140 kPLN – Malgorzata Frelek-Kozak

M. Frelek-Kozak Mechanical behaviour of ion-irradiated ODS RAF steels strengthened with different types of refractory oxides Applied Surface Science 2022 (under review)

Micro-tensile, HV (about 450), NI, XRD, SEM/FIB, TEM

NCBJ Materials Research Laboratory – Other Materials Research Activities

Studying radiation damage in ODS-CSA steels

Motivation:

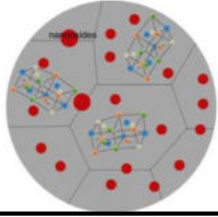

Oxide dispersion strengthened (ODS) CSAs

Design principle to alleviate limitations –
Compositional complexity +
Structural complexity

Cooperation with prof. Y. Zhang (UTK, USA)

- I. ODS steel - 14 YWT (Fe-14Cr-3W-0.4Ti-0.2Y)
- II. CSAs – NiCoFe and NiCoCr
- III. ODS-CSAs – ODS-NiCoFe, ODS-NiCoCr, and ODS-NiCoFeCr

Irradiation - 3 MeV Ni²⁺ to 5 x 10¹⁶cm⁻² at 580°C and 700 °C

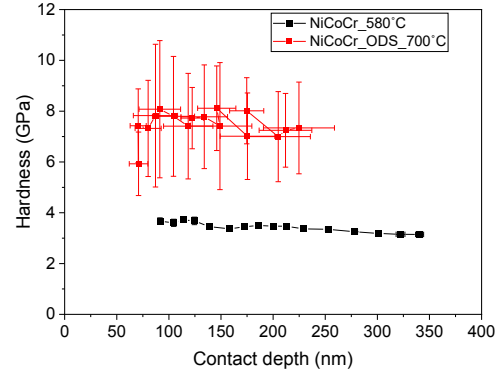
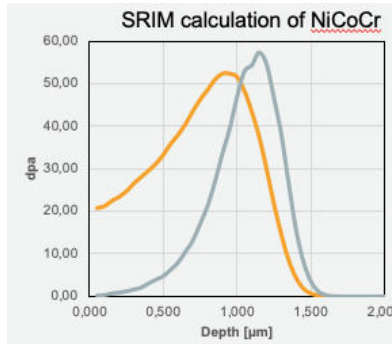

ODS-NiCoCr irradiated at 700°C

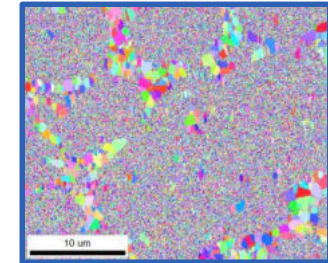
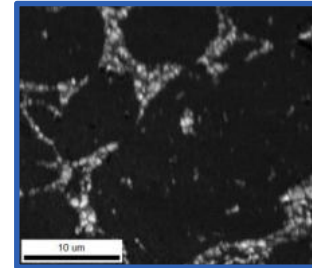

Minor temperature effect, ODS in CSA increases H (high scattering)

Experimental work to be carried: SEM/FIB/EBSD/EDS, XRD (BB & GID), TEM

NCBJ Materials Research Laboratory – Other Materials Research Activities

HEA manufacturing via SPS and AM to improve functional properties of alloys

Motivation: understanding the effect of mechanical alloying parameters on strength and structural properties of High Entropy Alloys

Results

- Manufactured CoCrFeNi have high mechanical parameters (i.e. yield strength vs impact toughness) in a wide range of temperature
- We observe a more homogenous structure after higher milling time and sintering pressure
- 60h milling time should result in single phase material
- Observed grain growth after annealing
- Presence of $M_{23}C_6$ carbides
- Matrix with almost equimolar composition

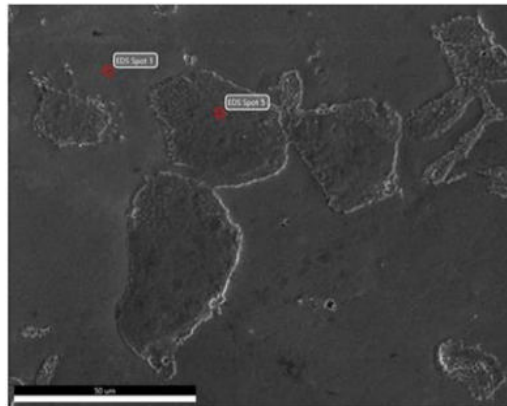
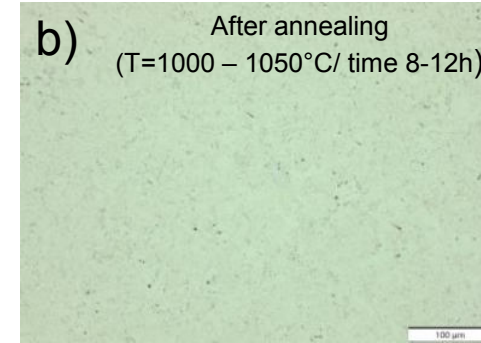
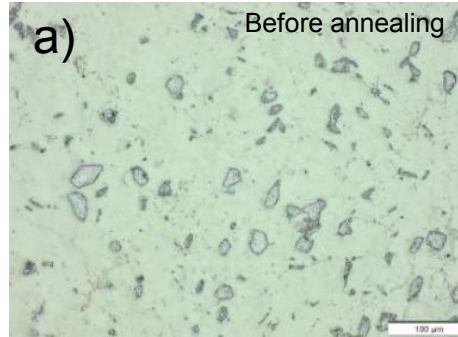

Matrix			
Element	Weight %	Atomic %	% Error
Co	24,24	23,14	3,91
Cr	23,31	25,21	3,59
Fe	28,16	28,36	3,76
Ni	24,29	23,28	4,36

Particle			
Element	Weight %	Atomic %	% Error
Co	2,83	2,52	8,65
Cr	92,39	93,08	2,5
Fe	3,17	2,97	7,78
Ni	1,6	1,43	14,15

Density – 96-97% of theoretical density

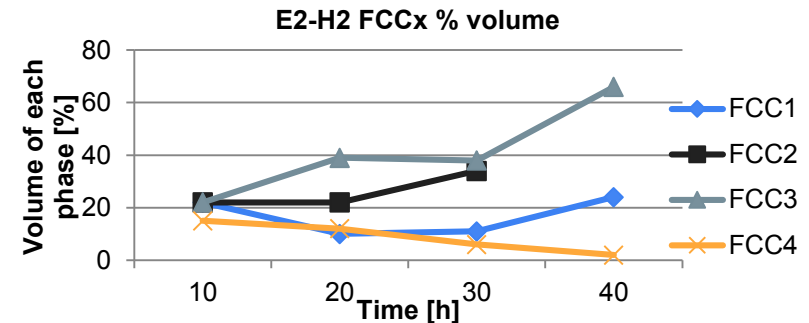

Measured HV below literature data

NCBJ Materials Research Laboratory – Other Materials Research Activities

Radiation damage build up mechanism in HEA bulk materials and coatings

HEA Bulk materials

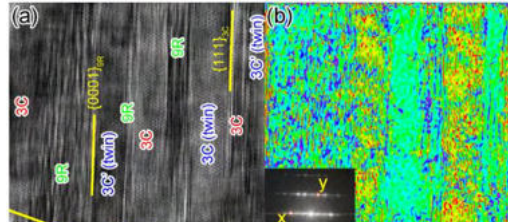
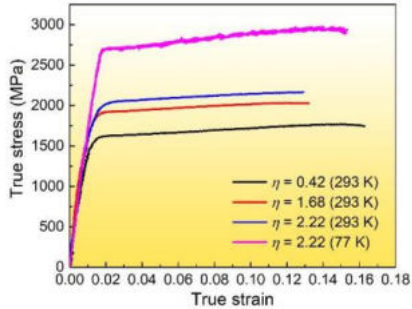

PLANS

The main goals of the research are:

- Understanding the irradiation damage mechanism of the CoCrFeNi with high strength.
- Study irradiation stability of different nanostructures in the HEAs (grain boundary, nanotwins boundary, sub-structure in nanotwins).
- Development of nano-twinned HEAs with superior mechanical properties and enhanced irradiation resistance

HEA Thin films

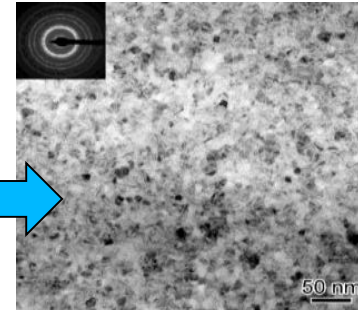
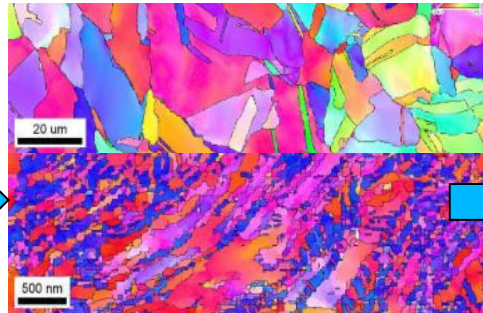
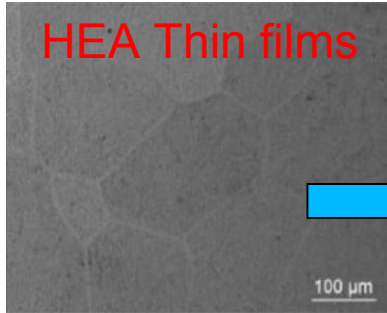

The aims of this work will be:

- Study the irradiation damage mechanism of the CoCrFeNi in the function of grain size (from micro to nanoscale).
- Understand irradiation stability of the micro- and nano- structures.

[1] W. Huo, et al. Remarkable strength of CoCrFeNi high-entropy alloy wires at cryogenic and elevated temperatures. *Scripta Materialia*, 2017, 141:125

[2] W. Huo, et al. Remarkable strain-rate sensitivity of nanotwinned CoCrFeNi alloys, *Applied Physics Letters*, 2019, 114: 101904

[3] W. Huo, et al. Fatigue resistance of nanotwinned high-entropy alloy films, *Materials Science and Engineering: A*, 2019, 739, 26

NCBJ Materials Research Laboratory – Other Materials Research Activities

Studying functional properties of amorphous Al_2O_3 coatings for advanced nuclear applications – studies performed in the frame of the GEMMA

MOTIVATION

Available materials such as stainless steels (e.g. 316L, 15-15Ti, T91, HT9) are not suitable for use in the LFR coolant environment → need to apply corrosion resistant coating

LFR FC operating conditions: up to 600 °C, up to 200 dpa, LL/LBE

25 dpa

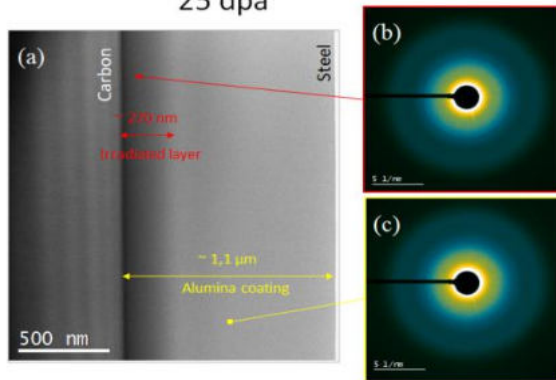

No significant effect of RT ion irradiation on material properties !!!

Publications:

1. A. Zaborowska et al., Surface & Coatings Technology (2019)
2. A. Zaborowska et al., Ceramics International (2021)
3. A. Zaborowska et al.two papers in review *IBMM and NuMat 2022 Conferences*

✓ High temperature properties

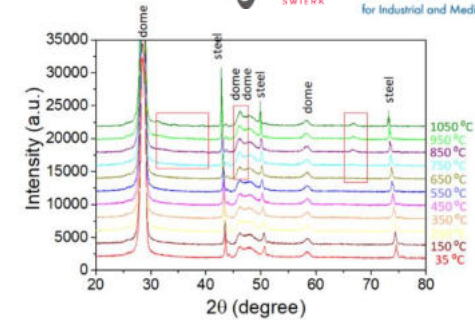
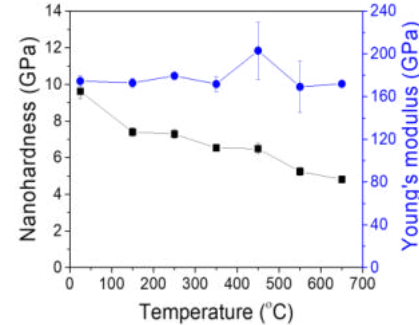

✓ High temperature radiation tolerance

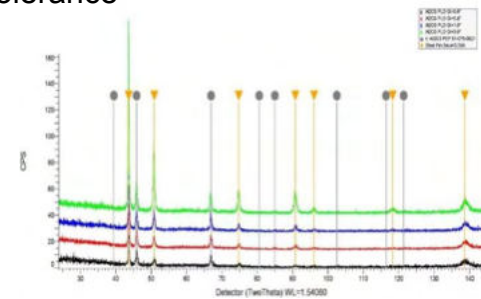
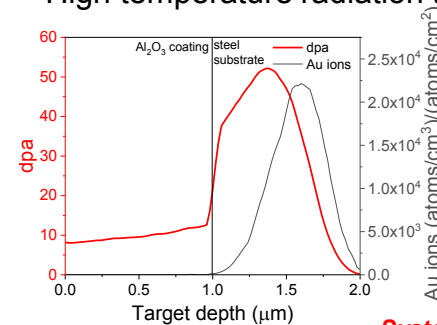

System proves to be mechanically well-matched at high temperature. Material undergoes a series of phase transformations (thermal crystallization above 650 °C). Synergetic effect of high temperature and radiation on crystallization.

NCBJ Materials Research Laboratory



Final Conclusions

- **We have a research laboratory with high-end research infrastructure**, which will be fully equipped and operational in the year 2023
- **We have a management system** under which we can carry out **accredited testing** and research in line with **international research and materials standards ISO, ASTM, BS...**
- **We have a young team of engineers** who continue to expand and develop their competencies...
- **We are willing to cooperate in materials testing with other Partners in the SafeG project...**

We invite you to cooperation...

NCBJ Materials Research Laboratory



Acknowledgements for cooperation to all Partners in **SafeG[®]**



Special Acknowledgements

Infrastructure and Research support for National Centre for Nuclear Research Materials Research Laboratory is provided by The Ministry of Science and Higher Education in consultation with The Ministry of Climate and Environment within the Project HTGR High-Temperature Gas Cooled Reactor

PROJECT HTGR

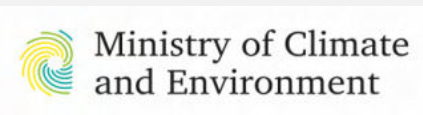

THANK YOU FOR YOUR ATTENTION

Materials Research Laboratory Contact Persons:

Łukasz Kurpaska, D.Sc., Ph.D.
Director of Materials Research Laboratory
National Centre for Nuclear Research
Andrzeja Sołtana st. 7, 05-400 Otwock, Poland
phone: +48 22 273 10 61
cell: +48 796 768 038
e-mail: lukasz.kurpaska@ncbj.gov.pl

Jaroslaw Jasinski, D.Sc.
Head of Structure and Corrosion Division
Materials Research Laboratory
National Centre for Nuclear Research
Andrzeja Sołtana st. 7, 05-400 Otwock, Poland
Phone +48 22 273 10 62, / Cell. +48 507 941 657
e-mail: jaroslaw.jasinski@ncbj.gov.pl

SafeG³

SAFETY OF GFR THROUGH INNOVATIVE MATERIALS,
TECHNOLOGIES AND PROCESSES



This project has received funding from the Euratom H2020 programme
NFRP-2019-2020-06 under grant agreement No 945041.

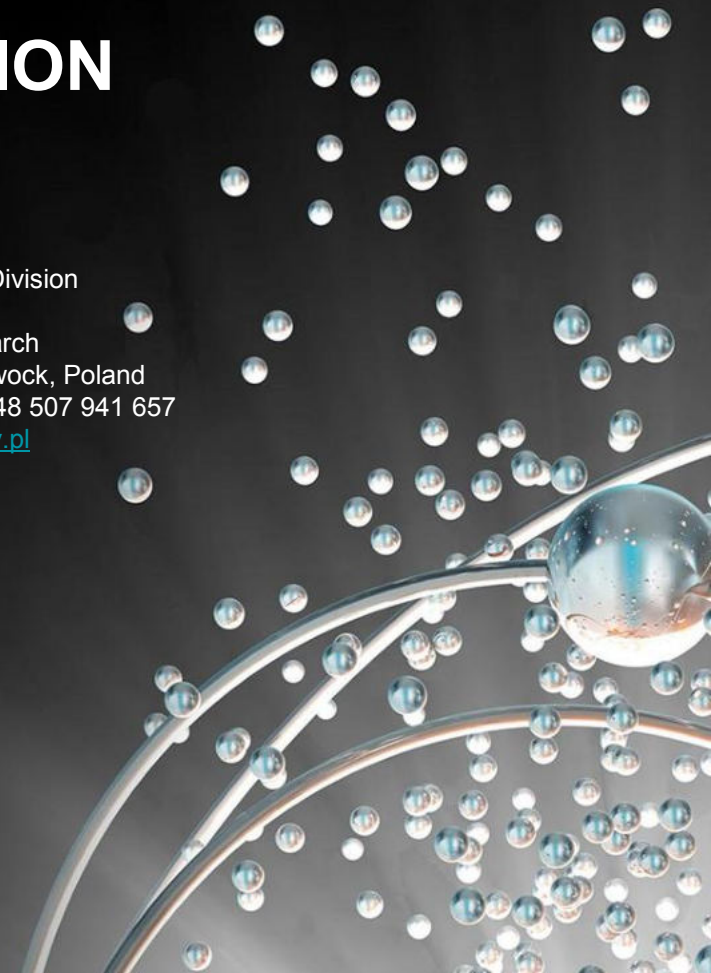

Engineering Aspects of Gas Cooled Reactor Technology

doc. Ing. Václav Dostál, Sc.D.



FAKULTA
STROJNÍ
ČVUT V PRAZE



Ústav energetiky

$$\frac{\partial \rho}{\partial t} + \nabla \cdot (\rho \mathbf{v}) = 0$$
$$PV = nRT$$
$$\lim_{T \rightarrow 0} S = 0$$

Outline

- Gas cooled reactor concepts
- History of gas cooled reactor technology
- Recent trends
- Considerations for gas cooled reactor design
- Czechoslovakian experience: A-1 nuclear power plant



Types of Gas Cooled Reactors

Gas-cooled reactor (graphite moderated, CO₂ cooled)

- Magnox (British design, 28 built, 1956-2015)
- UNGG reactor (French design, 10 built, 1956-1994)
- Advanced Gas-cooled Reactor (Magnox successor, 15 built, 1962-today)



Types of Gas Cooled Reactors

Heavy water gas cooled reactor (heavy water moderated, CO₂ cooled)

- Lucens Experimental Nuclear Power Reactor (1966-1969)
- Brennilis Nuclear Power Plant (1967-1985)
- **KS 150 (1972-1979)**



Types of Gas Cooled Reactors

High & Very-high temperature reactor (graphite moderated, Helium cooled)

Prismatic block reactor

- Dragon reactor (1964-1975)
- Peach Bottom Atomic Power Station (1967-1974)
- Fort Saint Vrain Generating Station (1979-1989)
- High-temperature engineering test reactor (1999-today)
- Gas Turbine Modular Helium Reactor (General Atomics design)
- Steam Cycle High-Temperature Gas-Cooled Reactor (Areva SMR design)

Types of Gas Cooled Reactors

Pebble bed reactor

- AVR reactor (1966-1988)
- THTR-300 (1983-1989)
- HTR-10 (2003-today)
- HTR-PM (2021-today)
- Pebble bed modular reactor (design)



Types of Gas Cooled Reactors

Gas-cooled fast reactor (No moderator, Helium cooled)

- Energy Multiplier Module (General Atomics design)



Gas Cooled Reactors Characteristics

Why gas cooled reactors?

- Possibility to use natural uranium
- Possibility to produce plutonium
- Possible high coolant outlet temperature – better efficiency, use for process heat
- No phase change – heat transfer crisis, void coefficient, clean coolant
- Possible lower pressure
- Possibly lower hydrogen explosion risk



Gas Cooled Reactors Characteristics

- Large dimensions – for thermal systems
- Low power density
- Large pumping power – 10x more than PWR
- Large thermal inertia – for thermal system
- Corrosion issues
- Often fuel cladding cannot be stored for long times in a spent fuel pool making nuclear reprocessing mandatory

Gas Cooled Reactors Choices

Coolant – He/CO₂

- Helium is transparent to neutrons
- CO₂ radiolysis and decomposition
- Suffocation by CO₂
- Experience
- Cost
- Leakage/Ingress/Contamination
- Corrosion – every 10°C chem. reaction increases 2-4x
- Achievable temperature
- Available materials
- Component lifetime

Gas Cooled Reactors Choices

Moderator – graphite/heavy water

- Nuclear graphite is more expensive than light water but less expensive than heavy water
- Graphite lifetime
- Use of natural uranium with graphite is difficult
- Graphite is flammable and is exposed to high temperatures in operation - a graphite fire is a possible accident scenario
- Boudouard reaction between graphite moderator and CO₂ coolant can produce explosive and poisonous carbon monoxide
- A loss of coolant accident, unlike in a water moderated reactor, does not by itself cause a scram

Gas Cooled Reactors Choices

Fuel

- natural/enriched
- metal/oxide
- block/pebbles/pins

Cladding

- Mg (Al)
- Mg/Be
- Zr
- SiC

Refueling

- Online
- Batch



Gas Cooled Reactors Choices

Spectrum

- Thermal – large dimensions required for cooling work well with moderator requirements, especially graphite
- Fast – requirement on tight core goes against safety

Gas Cooled Reactors Choices

Power cycle

- Steam
- Gas cycle

Direct/indirect cycle



A-1 NPP



NPP A-1 with the reactor KS 150

Power	560 MWt
Fuel	Přírodní uran
Fuel loading	24 600 kg
Moderator	D ₂ O
D ₂ O loading	57 200 kg
Number of channels	148
Number of control rods	40
Coolant	CO ₂
Coolant temperature Inlet/Outlet	112 / 426° C
Coolant pressure Inlet/Outlet	6,5 / 5,5 MPa
Coolant mass flow	1 576 kg/s
Coolant velocity	max. 60 m/s

Secondary loop :

Dual pressure PG number	6
Feed water temperature	97° C
Steam outlet temperature	410° C
Steam outlet pressure	5,3 MPa
Steam per PG	86 t/hod.
Number and power of el. generators	3 x 50 MWe

Construction ends in 1972

KS 150 description

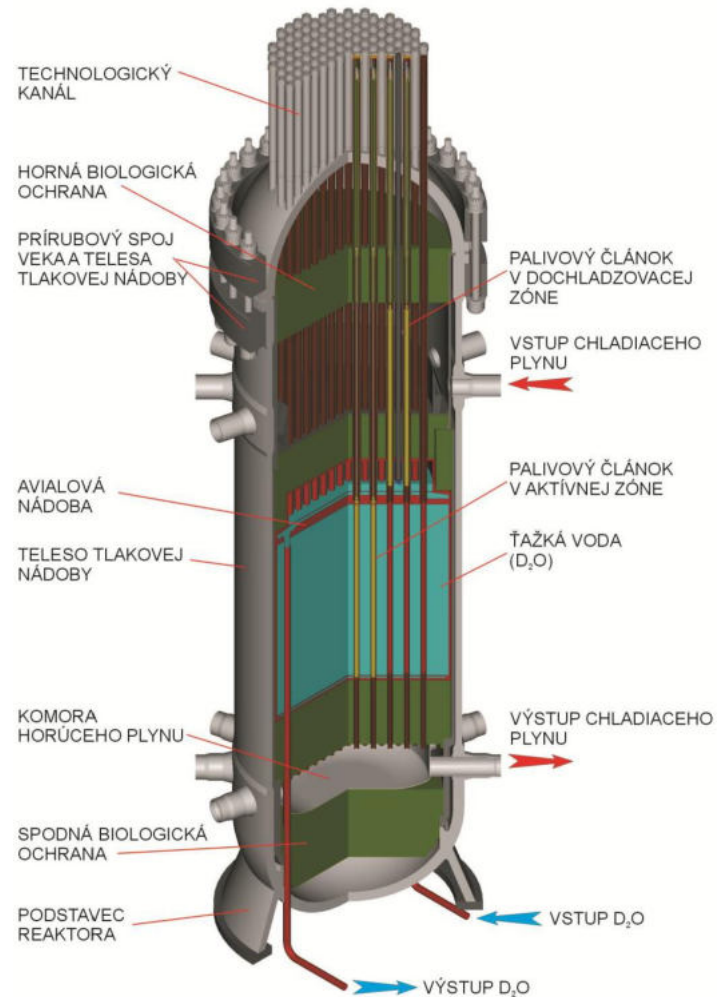

A-1 control room

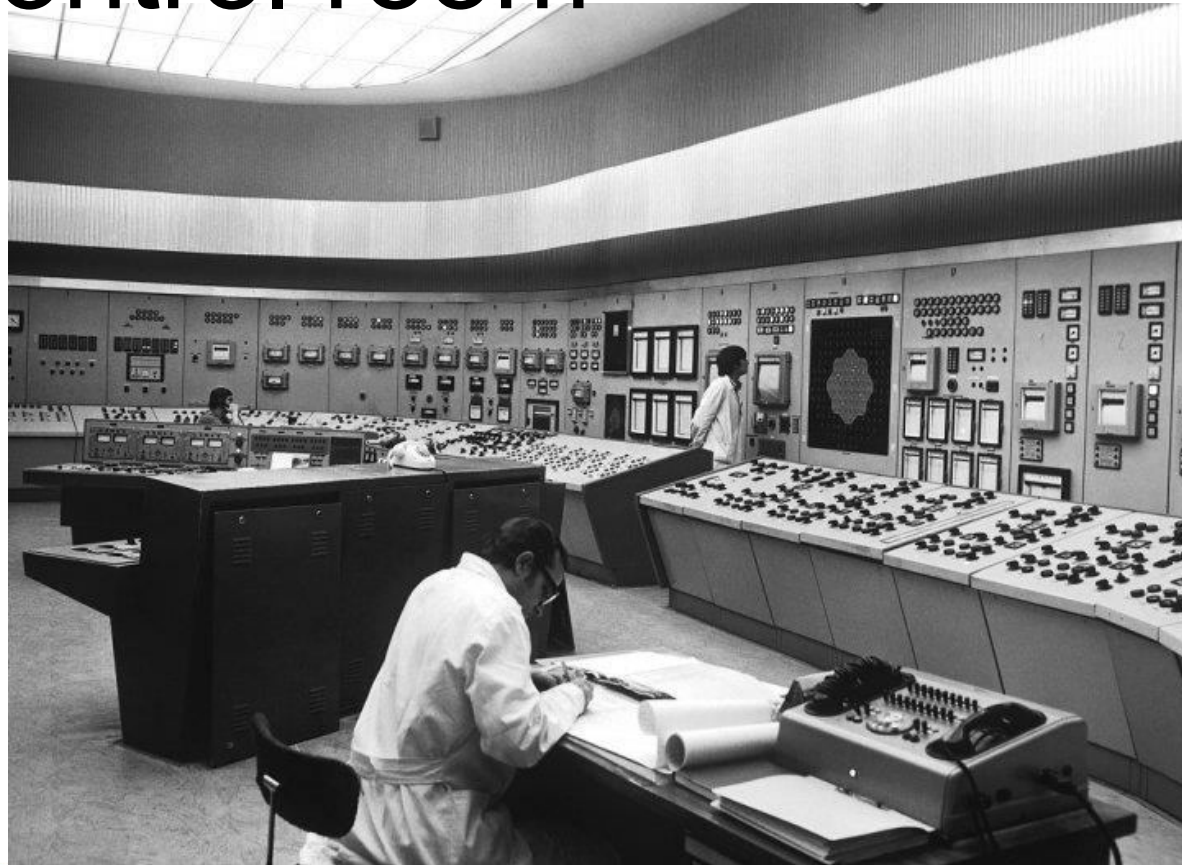

First grid connection

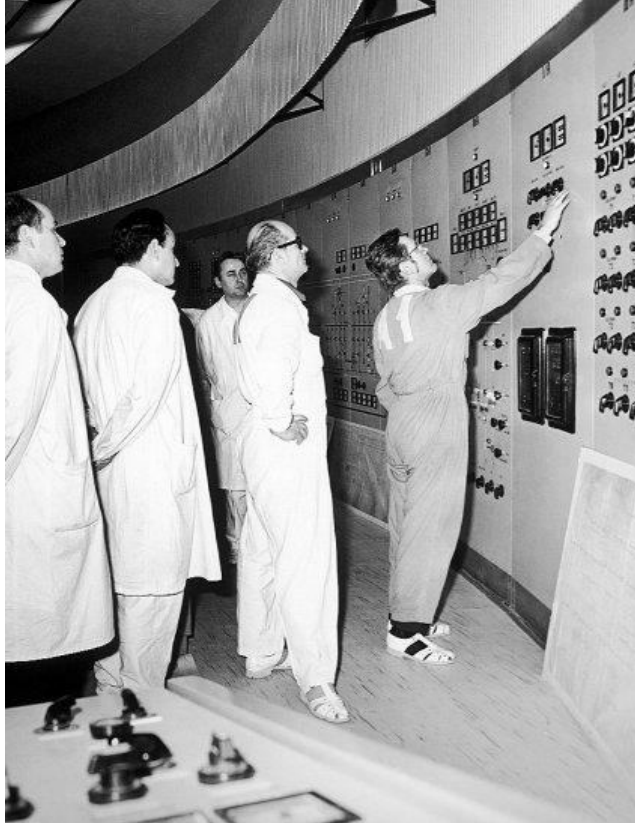

December 25th, 1972

Reactor hall with refueling machine

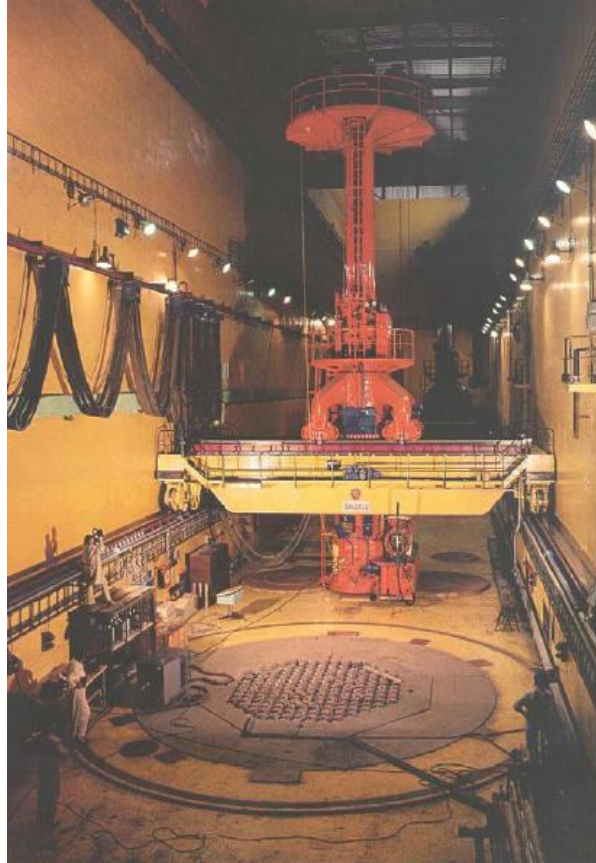

Reactor and technological channel

Interconnecting pipes

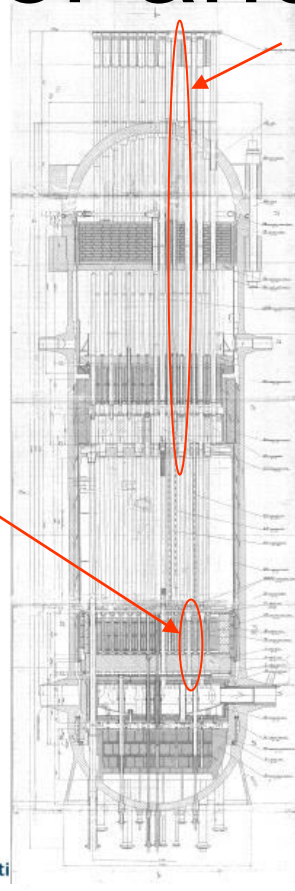

Reactor A-1

TK



Upper part of the tech. channel

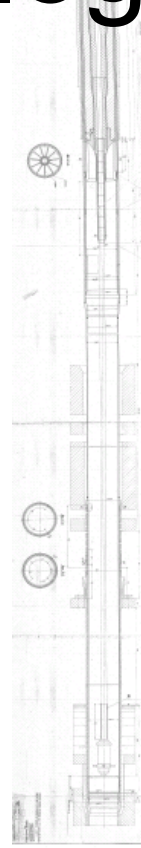

Lower part of the tech. channel



Interconnecting pipe

Locking mechanism

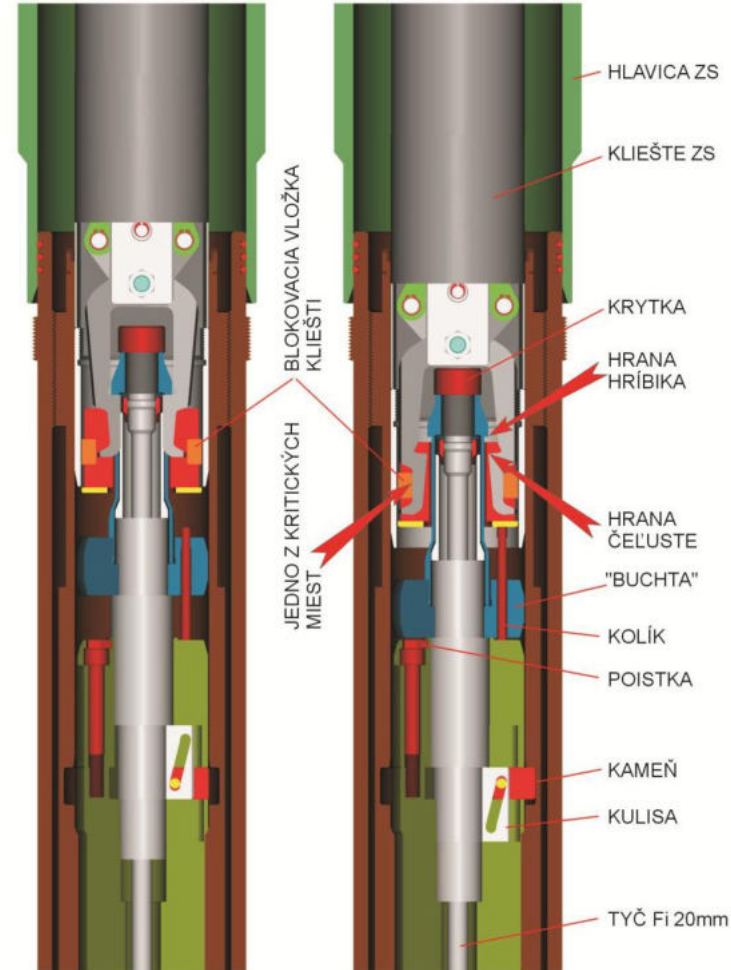
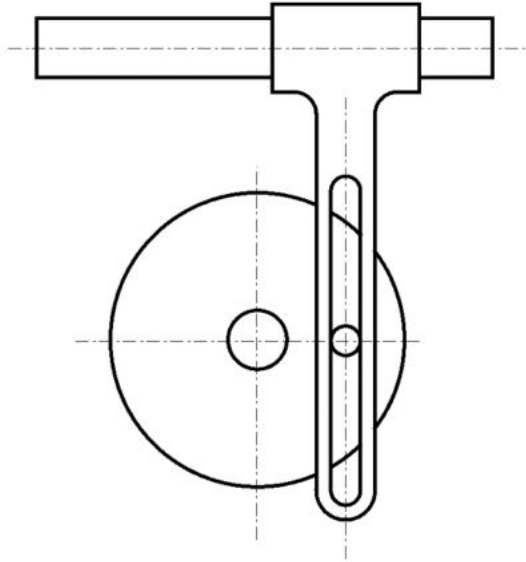

CO2 flow regulation

Inlet orifice allows flow regulation for each channel

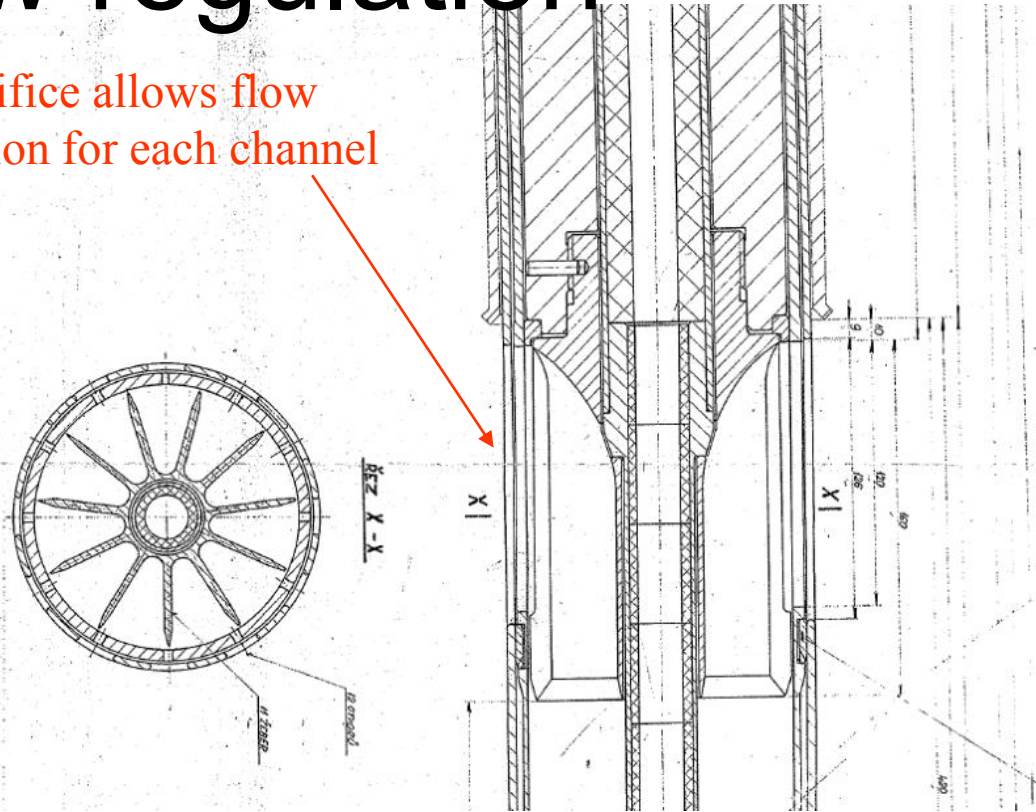

Fuel assembly

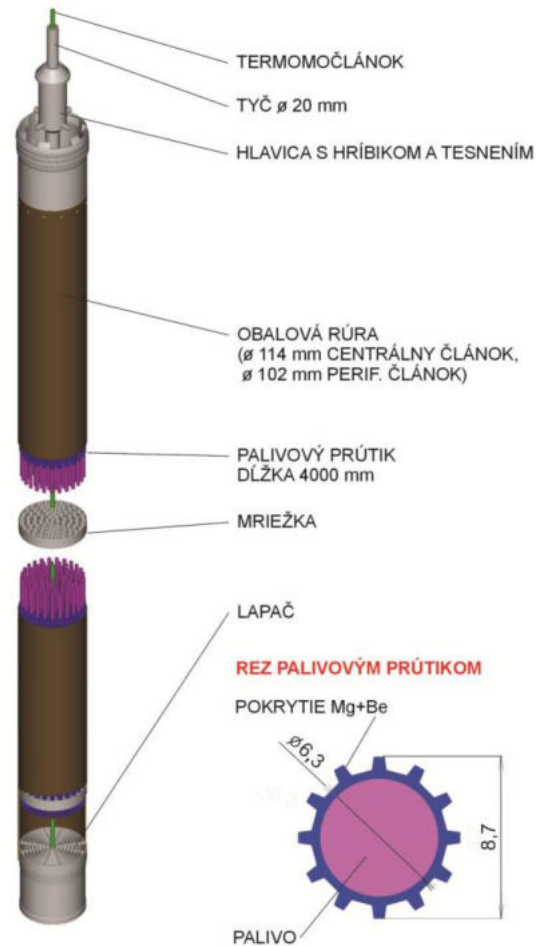

Two Accidents at the A-1 NPP



František Hezoučký

SÚJB 10.6.2014

František Hezoučký



Receiving state award, Medal for Merits of the 1st Order

Prof. Burgov at the A-1 control room during commissioning

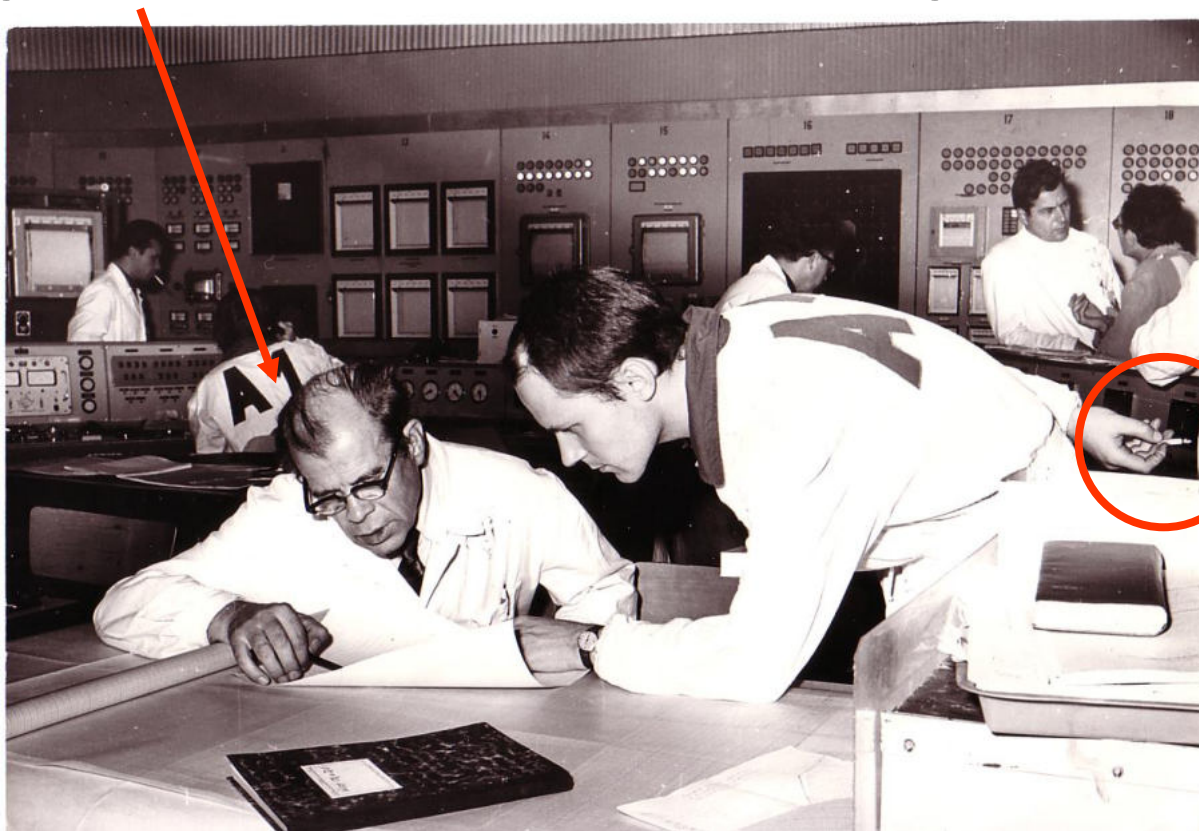

The first accident – January 5th 1976



Accident sequence

- On January 5, 1976, a standard replacement of the fuel assembly (FA) in the technology channel (TC) H-05 took place at reactor A 1 in Jaslovské Bohunice.
- The refuelling machine (RM) removed the spent fuel assembly from the cooling zone, inserted fresh FA into the aftercooling zone of the reactor and drove off to deposit the spent fuel assembly in short-term storage (SS), where it was supposed to wait for residual power reduction before being placed in long-term storage (LS).
- The fresh FA was to be inserted from the cooling zone into the core by crane after connecting the $\varnothing 36\text{mm}$ extension rod to the hanger and the $\varnothing 20\text{mm}$ rod connector.
- At 11:55 a fresh FA was ejected together with the plug assembly (sealing and shielding) into the reactor hall and CO₂ began to leak out of the reactor into the reactor hall (RH) from the plug hole.
- Workers of the transport technology group (TTG) escaped from RH and CO₂ was flooding the entire main production block (MPB).

Accident sequence

- The shift engineer (SE) immediately announced the evacuation of the MPB over the radio and informed the operational deputy and the production manager. He sent Mr. Hezoučký to help the shift.
- The evacuation of MPB went well thanks to the quick thinking of some employees (Rostislav Petřek saved a group of workers from suffocation. When he found out where the CO2 cloud was coming from, he turned the group's course and found another exit from MPB)
- The shift has already initiated a number of steps to mitigate the situation.
- There was a stand-by SE in the control room who started helping the serving SE.
- The operating regulations did not anticipate this kind of accident and therefore the shift was not prepared. They had to improvise.
- Some steps were not correct and corrections had to be made.
- One of the mistakes was switching the turbocompressors from 3000 rpm to 600 rpm (at 12:05 p.m.), which caused a fivefold reduction in core cooling intensity.



Accident sequence

- Mr. Hezoučský ran to the block control room (BD) ~ 12:15.
- He asked the shift to immediately restore the operation of the turbo compressors to 3000 rpm, but due to complex blockages, the run-up was only possible at 13:04, only on the fifth attempt.
- The failed attempts were at 12:15, 12:31, 12:38, 12:44.
- The shift, in an effort to limit CO₂ output, also separated 4 circulation loops from the reactor.
- However, this accelerated the reduction of coolant pressure in the reactor and the loss of cooling intensity.
- The preliminary calculations indicated the impossibility of cooling the core by operating the turbocompressors at 600 rpm at atmospheric CO₂ pressure.
- Mr. Hezoučský therefore requested that the serving shift of the TTG in breathing apparatus return to the RH and try to close the technological channel with the loading machine.



Accident sequence

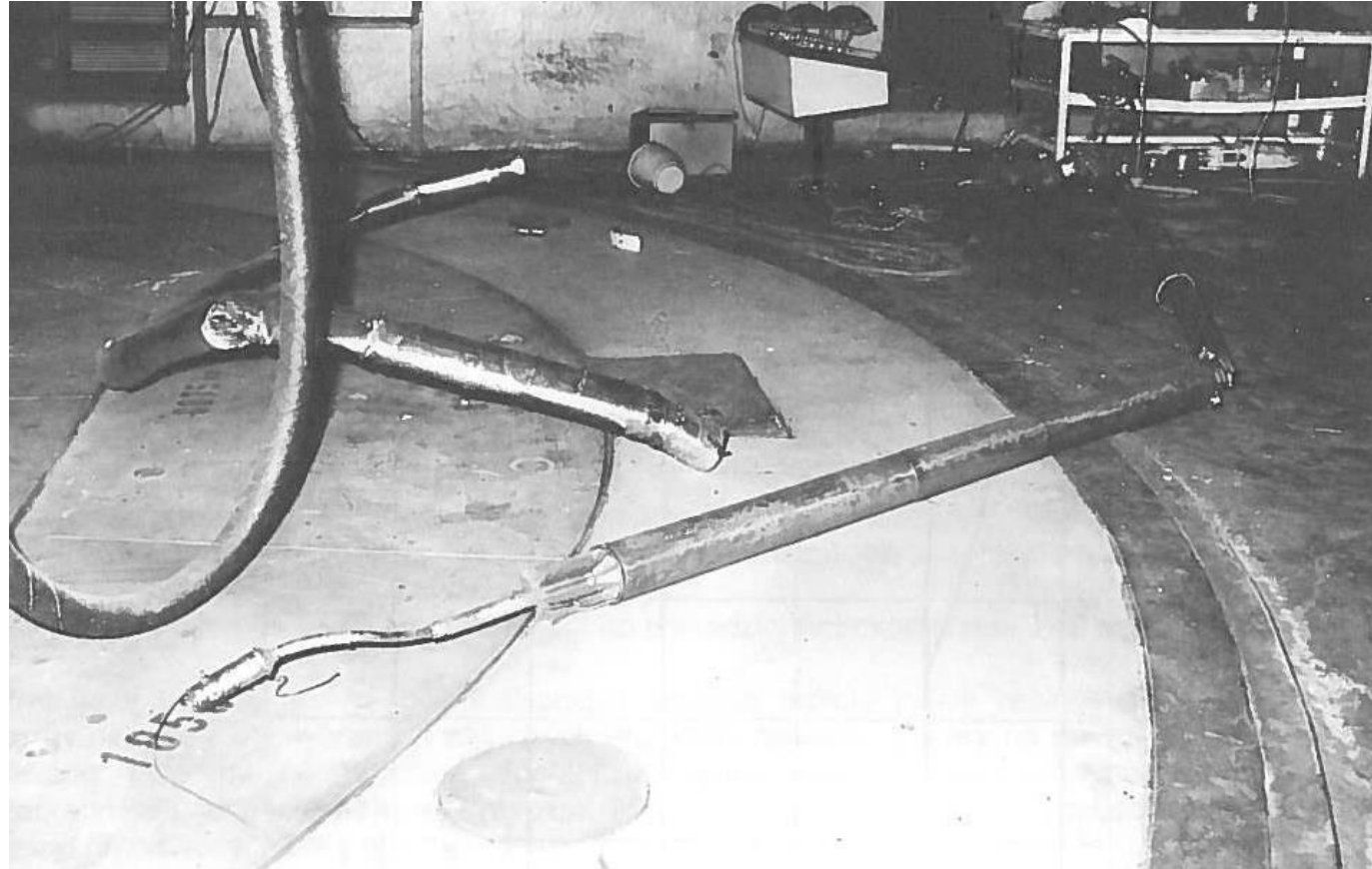

Accident sequence

- The ejected fuel assembly with a set of plugs obstructed the loading machine
- It was necessary to clear the way first so that the RM could drive over the reactor.
- In doing so, it was discovered that on the floor of the RS, in the vicinity of the first entrance to the RS, there is an interconnecting pipe with considerable induced radioactivity.
- TTG technician Viliam Pačes and dosimeter Milan Antolík, therefore used the second entrance to the RS.

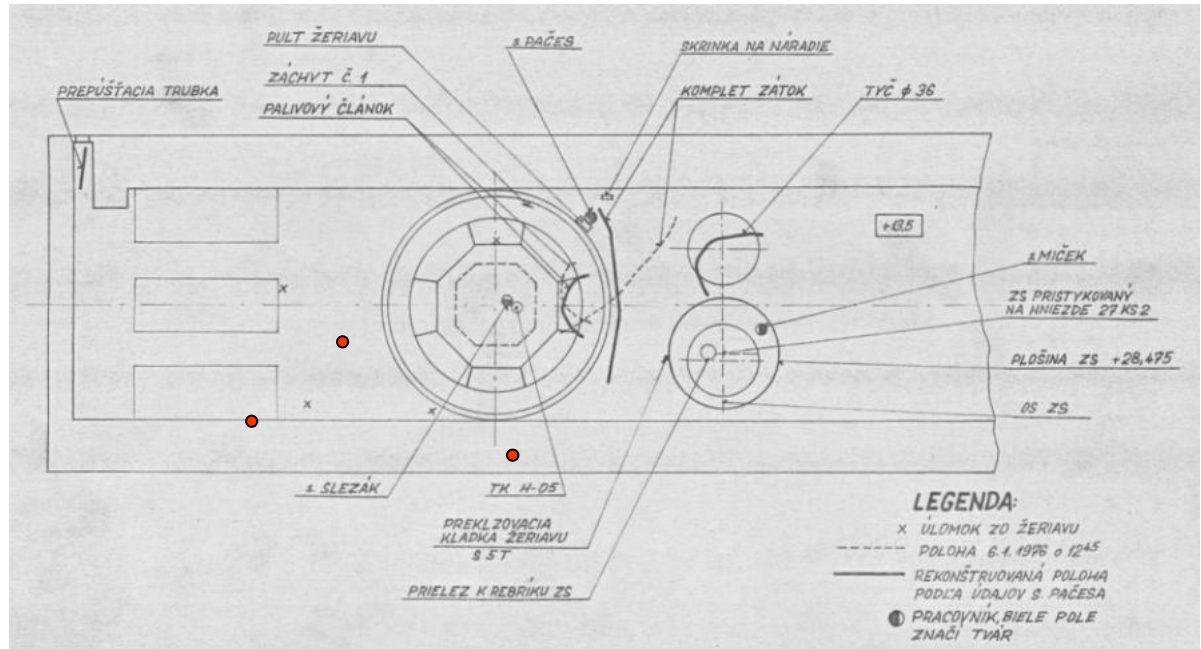

Accident sequence

- Viliam Pačes then manually drove the loading machine over TC H-05 (at about 12:40)
- The flowing CO₂ made it impossible to aim accurately at the reticle.
- As V. Pačes told after returning from RS, the image of the TC reticle waved in the eyepiece due to the CO₂ flow.
- The head of the RM did not land on the TC, because the exit from the TC was frozen due to CO₂ discharge.
- However, the restriction of the outlet caused the ice to melt and the head itself "sat" (at about 12:59) exactly at the TC.
- Work of V. Pačes was perfect, despite the difficult conditions.

Accident sequence

- Since it was not clear which of the steps would be successful, other steps were taken in parallel - connecting the reserve volumes and running the liquid CO₂ vaporizer from the gas management to increase the pressure in the primary circuit.
- After the reactor was sealed, these steps only led to the "insurance" of the cooling conditions.
- Unfortunately, two people suffocated from carbon dioxide
- The accident was never scaled, but could be considered INES 2-3

The second accident – February 22nd 1977



Accident sequence

- On February 22, 1977, the planned replacement of the fuel assembly in TK C-05 was carried out.
- Ø36 mm extension rod with an extension cable to ensure the measurement of the outlet temperature was connected.
- At 18:13 the inserion of the fresh FA (by crane) from the cooling zone to the core started.
- The CO2 temperature at the outlet was too high and the reactor power had to be reduced more than usual.
- After the the insertion of the fuel assembly, the TTG worker disconnected the extension cable and the operator started (fearing an increase in Xe poisoning) increasing the power of the reactor without checking the output temperature.
- At 18:27, the Ø36 mm rod began to slide out of the reactor.
- The employee of the TTG in the RH tried to prevent the extension with his own weight.

Accident sequence

- Increased humidity appeared in the primary circuit and the D2O level in the avial vessel began to drop.
- It was obvious that D2O was entering the primary circuit.
- The shift shut down the reactor.
- The radioactivity of the steam in some steam generators was also registered
- After the chemical regime worker was called, the D2O from the avial tank was transfered into the drain tanks so that its entire volume was not emptied into the primary circuit.
- PGs with radioactive vapor were separated from the reactor.



Accident sequence

- The increased CO₂ humidity caused damage to the cladding of all fuel in the reactor and thus contamination of the primary circuit with fission products.
- The two PGs into which the largest amount of D₂O moisture penetrated subsequently also showed increased CO₂ leaks from the primary to the secondary loop.
- The inserted fuel assembly "burned" in the lower half and burned through the caisson tube as well.
- The radiation impact on the environment inside and outside the NPP was insignificant

Accident sequence

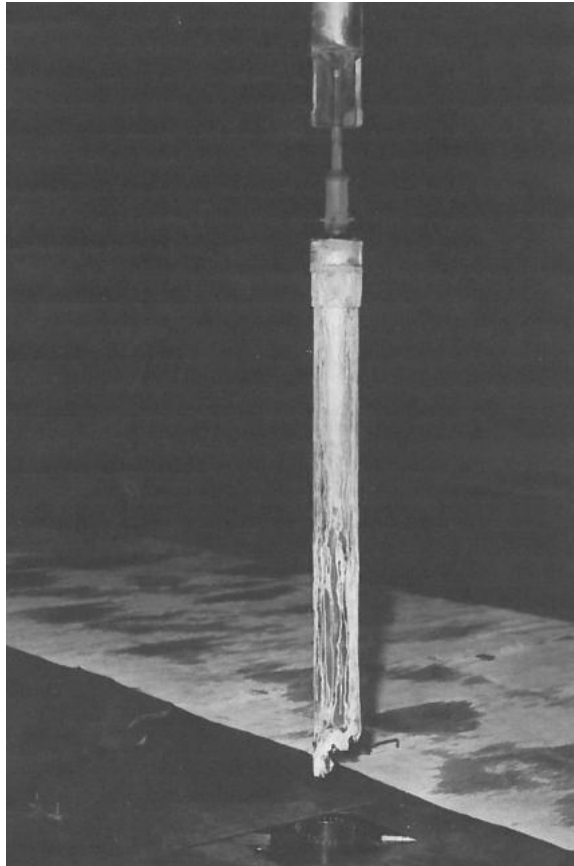

**Burnt fuel
assembly after
extraction to the
reactor hall**

Causes of the accident

- During the subsequent investigation, it was found that during the preparation of the fresh fuel cell, the workers of the fuel cell workshop noticed that the bag with silica gel, which was inserted as a moisture absorber at the time of their storage, was torn and the silica gel balls were spilled into the fuel assembly.
- They vacuumed up the silica gel, but it didn't occur to them that some of it was stuck inside the spacer grids.
- The FA had signed protocol as being fit to be taken into the reactor
- CO₂ could not fully cool the fuel, and its local overheating caused the fuel rods to melt and the caisson tube of the avial tank to burn.

Aftermath

After this accident, repair by replacing the caisson tube was considered, but it was subsequently decided to close the A-1 power plant.

It is currently being decommissioned.

This accident was graded 4 on the seven-point international INES scale.

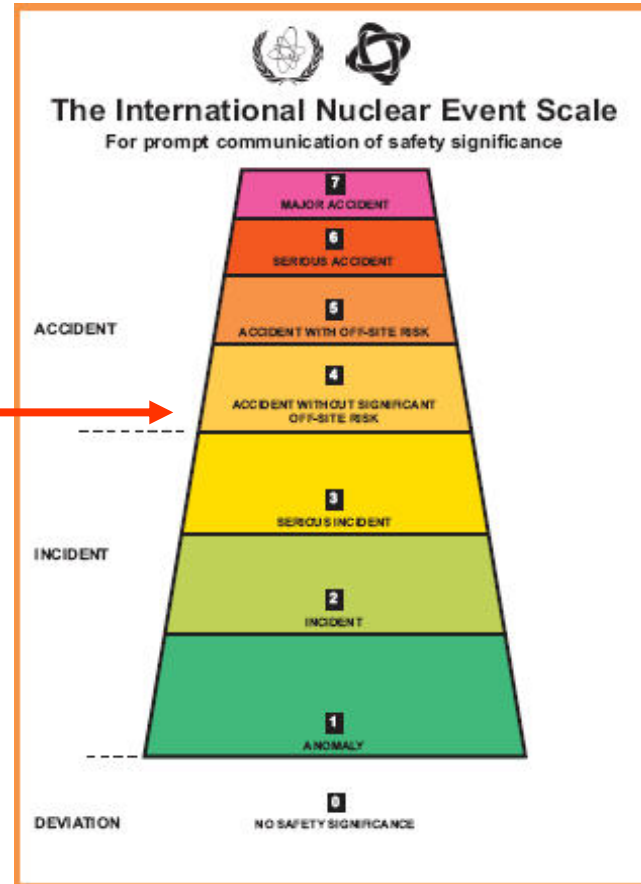

Thank you for your attention



GFR Summer School

Advanced Energy Technologies with a Potential for Use in GFR

Tomas Melichar, Martin Šilhan - CVR



This project has received funding from the Euratom H2020 programme
NFRP-2019-2020-06 under grant agreement No 945041.

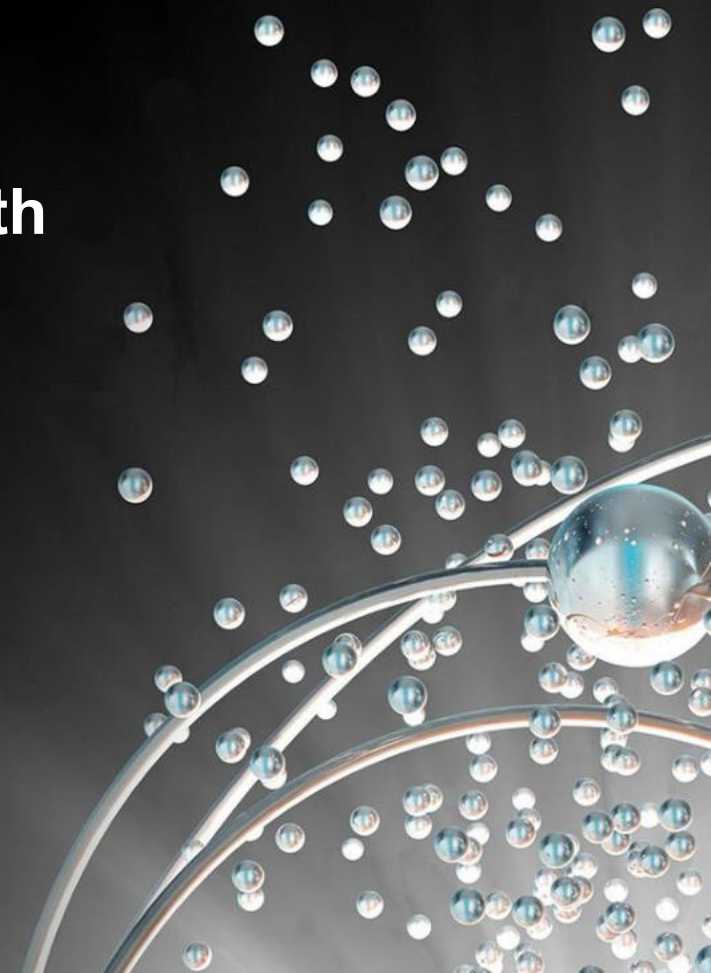

- Supplementary technologies that could be coupled with GFR
- Potential improvements
 - Increase of utilization factor
 - Increase of efficiency – increase of thermodynamic efficiency, decrease of self consumption
 - Stabilization of operational regimes, lifetime improvement
 - Improvement of economic balance
 - Demonstration of innovative technologies with potential of use in various fields
- Currently receiving attention especially in relation to SMR and Energy Islands
- Topics
 - Energy Storage (focused on Thermal Energy Storage)
 - Energy Conversion Cycles (focused on supercritical CO₂)
 - Hydrogen Technology (focused on High Temperature Electrolysis)

- Conversion of heat generated in the nuclear fuel to electricity (or district heating layout)
- GFR specific – high temperatures → potential for higher efficiencies
- Conversion cycle options:
 - Conventional Rankin steam cycles – most common but low temperature
 - Supercritical water cycles – developed but expensive technology
 - Gas Brayton cycles - pressurized gas as working fluid – applicable
 - Air Brayton Cycle – very high temperature option, low pressure, lower efficiency, components design challenging
 - Supercritical CO₂ cycle – applicable, high efficient but not demonstrated at larger scales

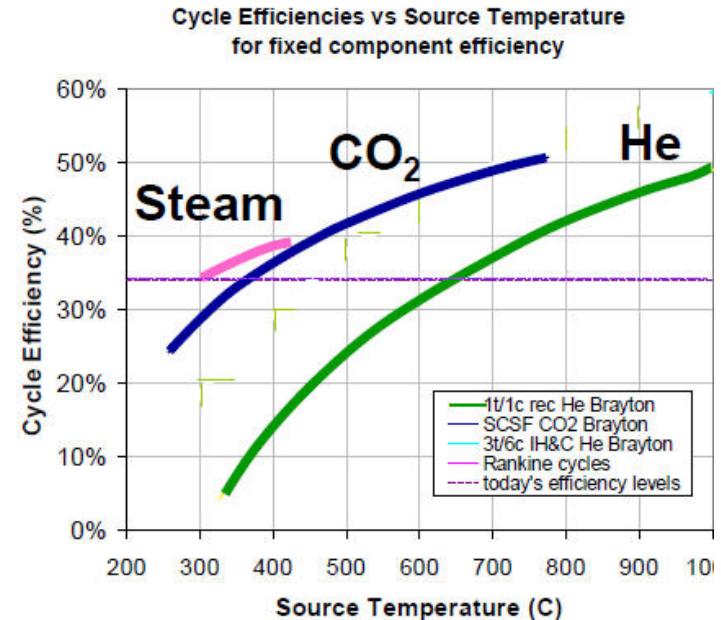

sCO₂ Cycles - Advantages

- CO₂ in supercritical state – above 74 bar and 31 °C
- Suitable thermo-physical properties
- Density like fluid and viscosity like gas
- Various application (fossil, renewables, energy storage, nuclear, waste heat)

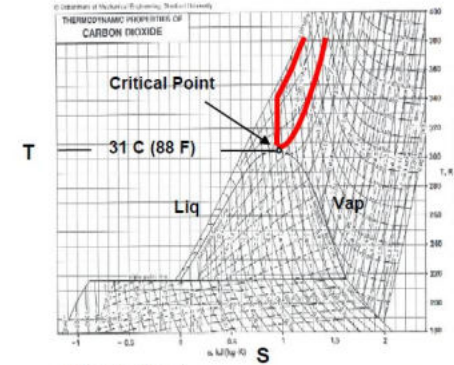

Rejects Heat
Above Critical Point
High Efficiency *Non-Ideal Gas*
Sufficiently High for Dry Cooling

Critical Point
88 F / 31 C
1070 psia / 7.3 MPa

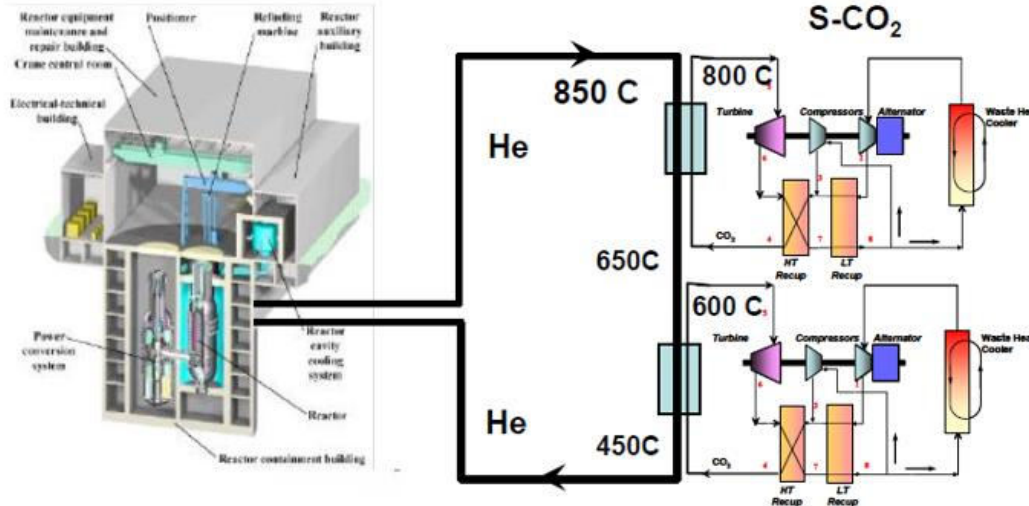

- Expected higher efficiency at higher temperature levels comparing to steam cycles
- Significantly smaller dimensions of components
- High flexibility
- No two-phase flow (reduced blade damage risk)
- Reduced cooling water needs
- Lower CAPEX expected
- High operational parameters, materials availability, lower technology readiness level

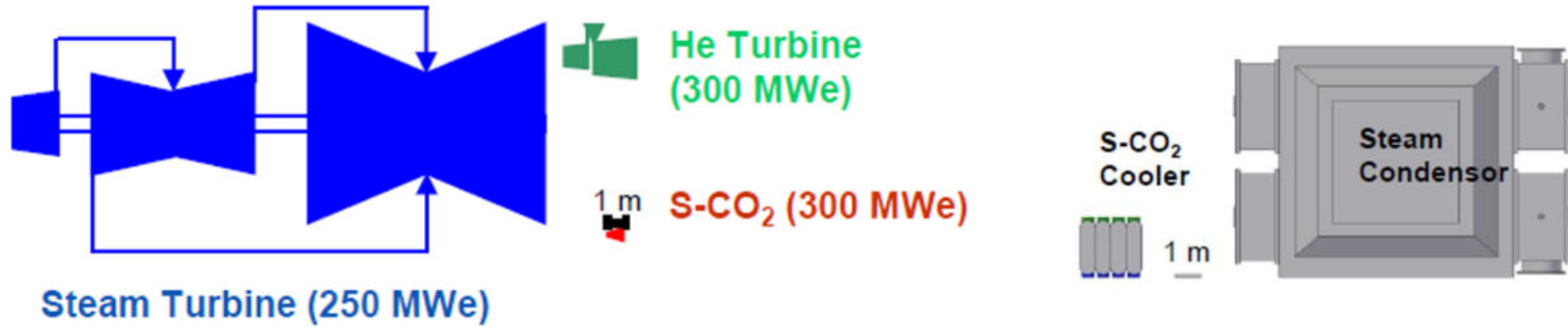

- There is many various layouts of the sCO₂ cycles
- Selection depends on application, operational parameters, power level

SIMPLE BRAYTON CYCLE WITH RECUPERATION

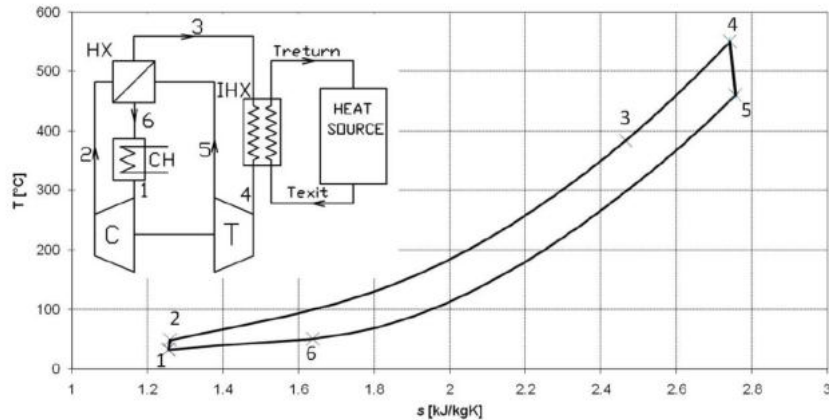

Simple Brayton Cycle Temperature - Entropy Diagram

RECOMPRESSION CYCLE WITH RECUPERATION

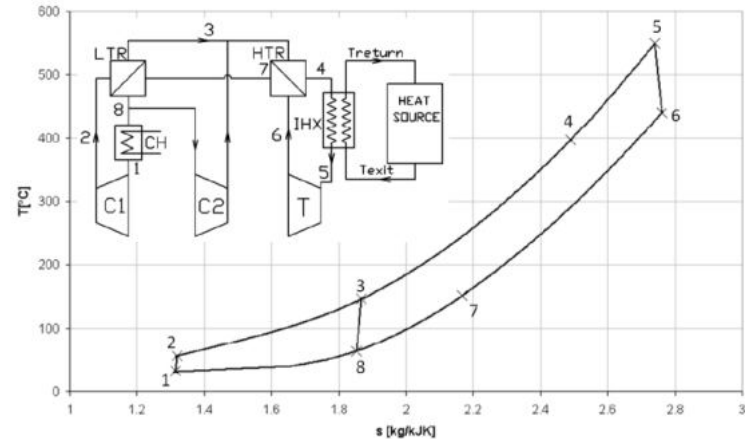

Recompression Cycle Temperature - Entropy Diagram

- The first sCO₂ experimental loop was realised in 1995 in Czech Republic (up to 0.25 kg/s, 300 °C and 25 MPa)
- Sandia National Laboratory – recompression cycle DEMO unit with 780 kWt / 122 kWe
- Echogen EPS100 – MW-scale DEMO unit (8 MWe), simple Brayton with recuperation, commissioned in 2014
- NET Power Allam Cycle – 50 MW DEMO unit with oxyfuel combustion and carbon capture

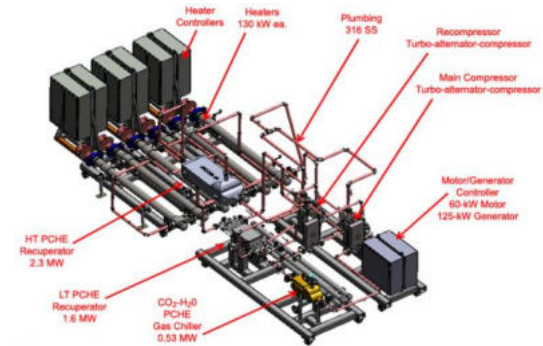

Engineering drawing of the piping layout for the S-CO₂ recompression Brayton Cycle.



- sCO₂ Loop of CVR
- In the form of simple Brayton cycle
- Up to 550 °C, 25 MPa and 0.3 kg/s
- Verification of systemic behavior
- Testing of components
- Collection of data for benchmarking

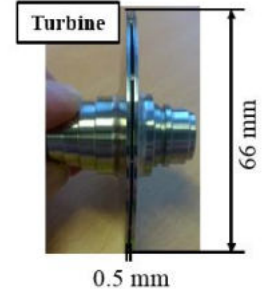
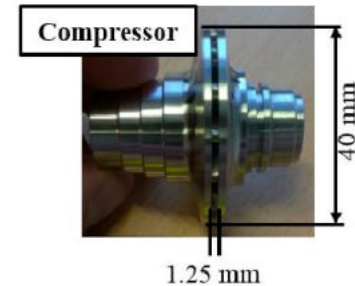
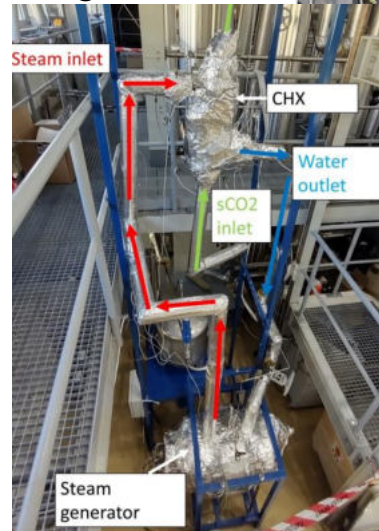

- SOFIA unit – 6 MWt (1.5 MWe) demo cycle
- Development of components
 - Axial power turbine
 - Compander (turbine-driven compressor)
 - Pressurizer
 - Starting compressor (motor driven)
- Cycle operation, components performance assessment
- Currently in the manufacturing phase
- Will be realized in Mělník power plant

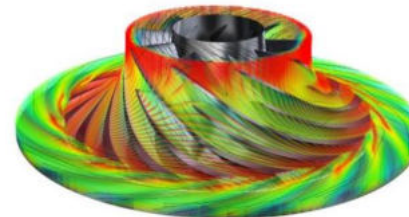
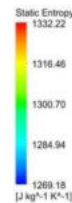
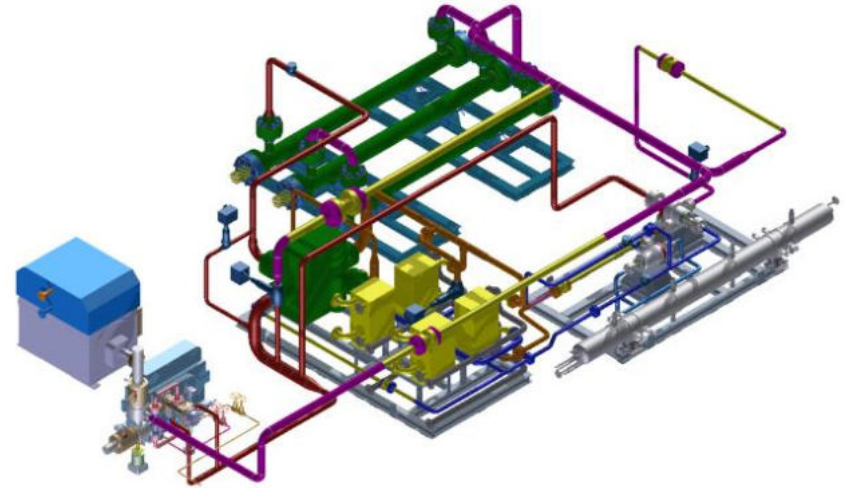

- Various principles of the bulk energy storage (electrochemical, mechanical, chemical, electrostatic, thermal)
- In combination with GFR, thermal energy storage systems (TES) should be preferable as the bulk energy storage units
 - Specifically the high-temperature concepts
- At the same time, TES has several advantages
 - Simple and available solution
 - Low investment cost
 - Scalable to practically unlimited capacities and powers, long storage times
 - Geologically independent



- Configuration of TES depends on storage material
 - Selection of storage material depends on required operational parameters
 - For GFR (75 MWt ALLEGRO case), following parameters of the TES might be suitable:
 - Input / output power – dozens (10-75) MWt
 - Capacity – hundreds (100 – 500) MWht, corresponding to several hours of storage
 - Operational temperature up to 750 °C
- Three types of storage materials (TES configurations)

SOLID

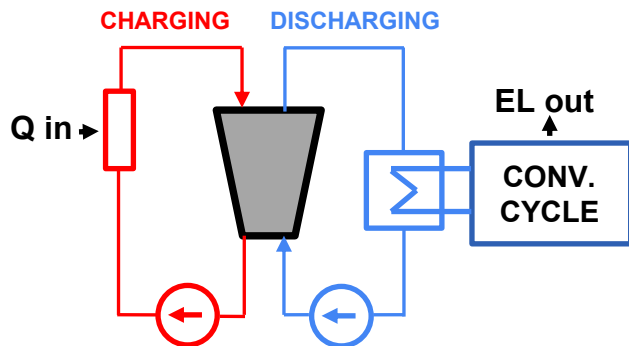

LIQUID

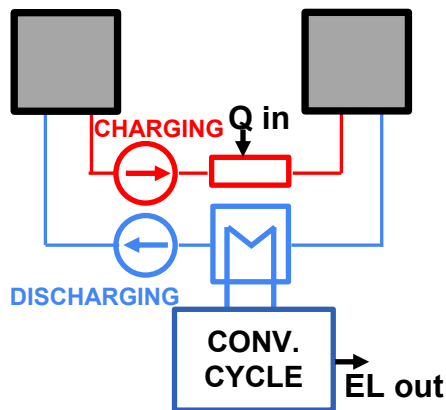

PHASE CHANGE

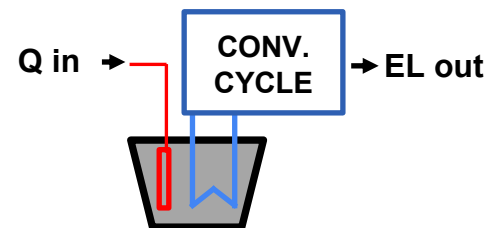

- Storage material in liquid phase
- Use of molten salts (solar salt $\text{NaNO}_3 + \text{KNO}_3$)
- Two tanks layout
- Available technology, widely use in CSP plants
- Largest units with > 1 GWh and > 100 MW
- Can be parallelized
- Molten salt tanks with $> 40\,000$ tuns and $> \varnothing 40$ m
- Can be parallelized
- Limited operational temperatures ($290\text{ }^\circ\text{C} - 550\text{ }^\circ\text{C}$)
- Round trip efficiency 35 %



Crescent Dunes Solar Energy Project

- Use of solid storage material
- Rock bed, ceramic or metal elements
- Need of heat transfer fluid (air)
- Cheap storage material, compatible materials
- High-temperature solution (750 °C)
- Pilot units available (SIEMENS Gamesa, Airlight Energy)
- The need of air heat transfer circuits limits the design power (heat exchangers design)
- Applicable for high capacities but lower power (< 10 MW)



G. Zangahen, A. Pedretti, S.A. Zavattoni, M.C. Barbato, A. Haselbacher
A. Steinfeld: Design of a 100 MWhth packed-bed thermal energy
storage, Energy Procedia 49 (2014) 1071-1077

TES – Solid Storage Material

- CVR's stand simulating conditions in rock-bed storage tank
- Testing of heat transfer and hydraulic performance
- Testing of rock stability at cyclic temperature loads
- Basalt rock selected as the most promising
- Low rock degradation observed



- Use of latent heat, high storage density
- At higher temperature, use of metallic materials is the option (Al, Si, Cu, Mg, Zr)
- Good thermo-physical properties
- → Simple and compact solution
- → No need of active elements in the storage side
- → Smaller heat exchangers
- Optimization of the operational temperature (up to 1414 °C)
- Corrosion environment
- Mechanical stress due to phase change



<https://1414degrees.com.au/what/>

TES – PCM – CVR's Concept

- CVR's concept of PCM TES
- AlSi12 as storage material
- Electrically heated, discharged through a sCO₂ cycle
- Heaters and HX immersed directly in the storage material
- Use of protective ceramic coatings
- Operational temperature 577 °C
- Small-scale demonstrator is being manufactured

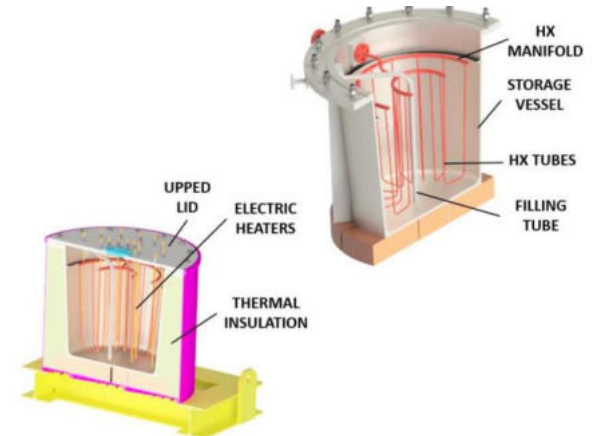
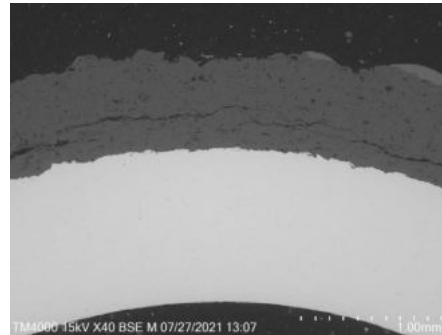
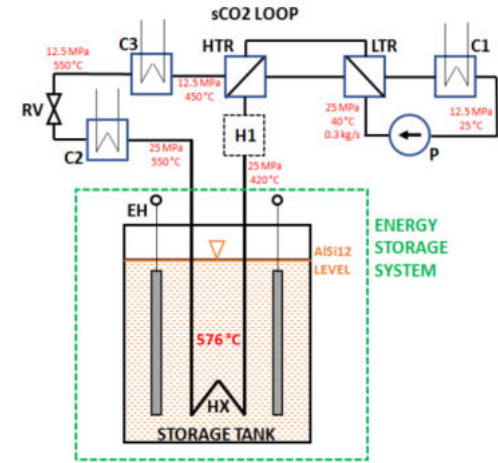

CAPEX for Constant capacity (150 MWht) and variable power

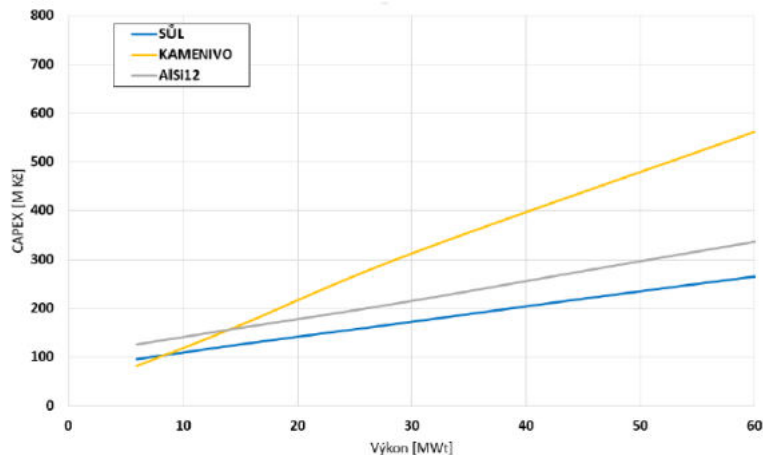

for Constant power (30 MWt) and variable capacity

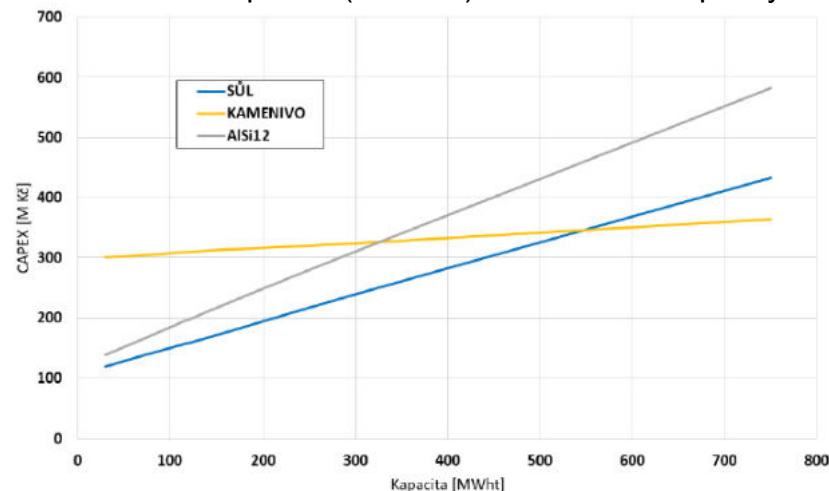

TRL
O&M
RTE
Lifetime
Flexibility
Siting options

MOLTEN SALT
High (TRL 9)
Mid
35 – 40 %
20 – 30 let
Střední
Good

ROCK BED
Mid (TRL 6) *
High
35 – 40 %
20 let *
Nižší
Good

AISI12
Low (TLR 3-5) *
Low
37 – 42 %
10 – 20 let **
Vysoká
Perfect

* Need for further development

- The hydrogen demand is growing rapidly, the projected capacities in 2030 have risen by 30 percent in the last two years
- Due to high-temperature spirit, GFR might be potentially coupled with H2 techs
- H2 production through high-temperature electrolysis, H2 utilization through fuel cell
- Alternative energy storage, fuel production, partial loads stabilization
- No competition to other storage technologies but diversification

- Purple/green hydrogen: produced by electrolysis using nuclear PP
- Green: electrolysis, using renewables
- Grey, brown, black: natural gas, coal
- Blue hydrogen: production from fossil fuels, but together CCS / CCU
- Yellow hydrogen: electrolysis from grid electricity
- Green hydrogen: from fossil fuels, will dominate up to 2040
- In 2050, 50 – 75 % of total world hydrogen supply, will be decarbonised
- Globally, hydrogen and subsequent fuels, can build up to 20 % volumes on energy markets

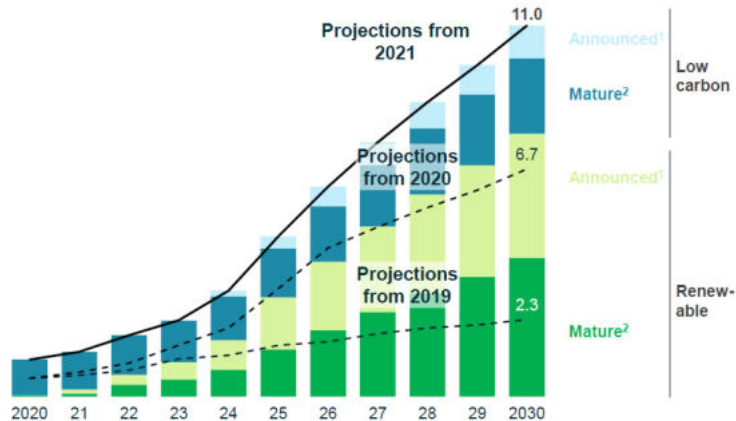

1. Includes projects at preliminary studies or at press announcement stage
2. Includes projects that are at the feasibility study or front-end engineering and design stage or where a final investment decision (FID) has been taken, under construction, commissioned and operational

Alkaline electrolyzer

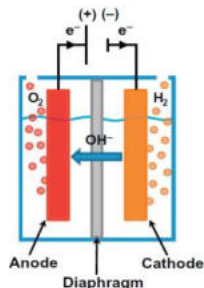

Polymer-electrolyte membrane electrolyzer

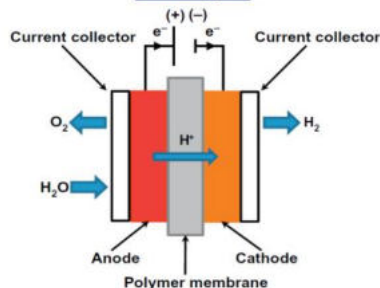

Solid oxides electrolyzer

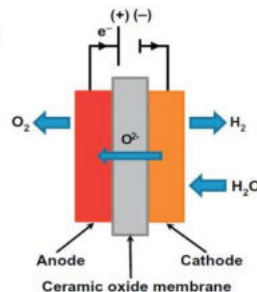

- Charge transferred through ions (O^{2-}) instead of electrons (LTE)

- Requires approx. 35 % less electricity than LTE
- No need of rare and toxic materials
- Reversible process (one facility for both electrolysis and fuel cell)
- Co-electrolysis possible
- No active cooling needed
- High-temperature ceramic materials needed
- Low thermal gradients (1 K / min to 600 – 900 °C → up to 15 hours)
- However, once at operational temperature, flexibility is high
- Lower lifetime, higher price

- HTE uses steam enthalpy but less electric power
- Might be preferable in case of increasing price of electricity

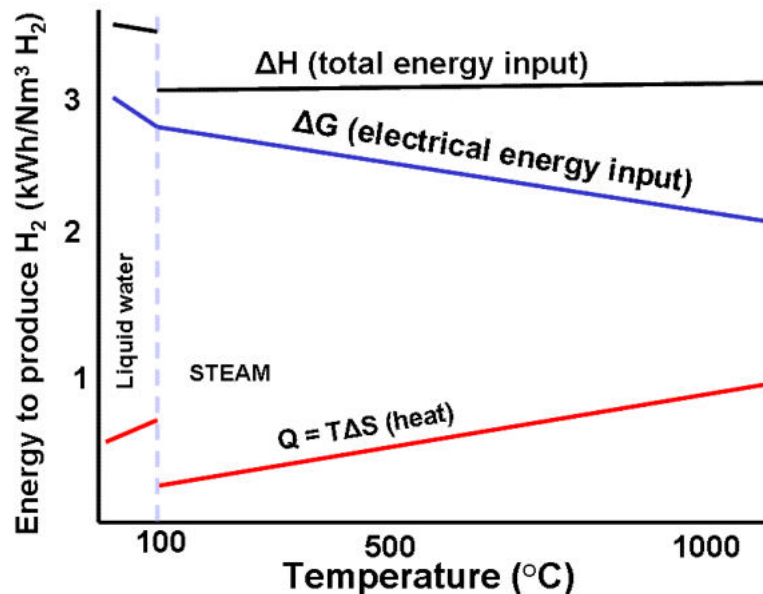

“When steam can be preferably generated from waste heat sources, such as in steelmaking, high temperature electrolysis is the most efficient technology.”

Prof. Dr.-Ing. Heinz Jörg Fuhrmann, Chief Executive Officer and Chairman of the Executive Board of Salzgitter AG

Sunfire-HyLink / SynLink

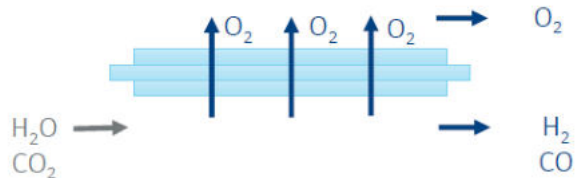

3,7
4
but:

$\text{kWh}_{\text{AC}} / \text{Nm}^3 \text{H}_2 \text{LHV}$
mil EUR / MW CAPEX
the price includes a fuel cell and
co-electrolysis possible. Potential for
price reduction with further development

PEM electrolysis

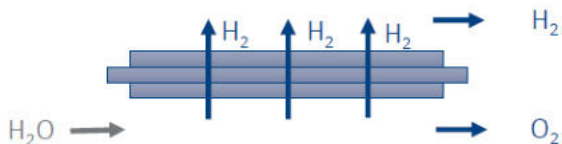

5-6
1,2

$\text{kWh}_{\text{AC}} / \text{Nm}^3 \text{H}_2 \text{LHV}$
mil. EUR / MW CAPEX

Alkaline electrolysis

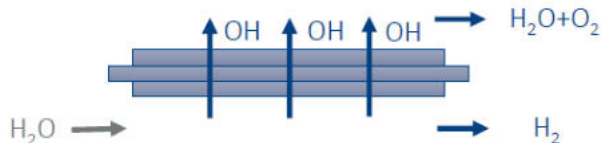

5-6
1,4

$\text{kWh}_{\text{AC}} / \text{Nm}^3 \text{H}_2 \text{LHV}$
mil. EUR / MW CAPEX

HTE - Layout

- MEA – Membrane-Electrode Assembly (cathode, electrolyte, anode), also „hydrogen-side“ and „air-side“ electrode
- The thinner, the lower electric resistance
- Anode-supported MEA – total thickness 0.3 mm
 - Electrolyte 0.01 mm
 - Cathode 0.03 mm
 - Anode 0.25 mm

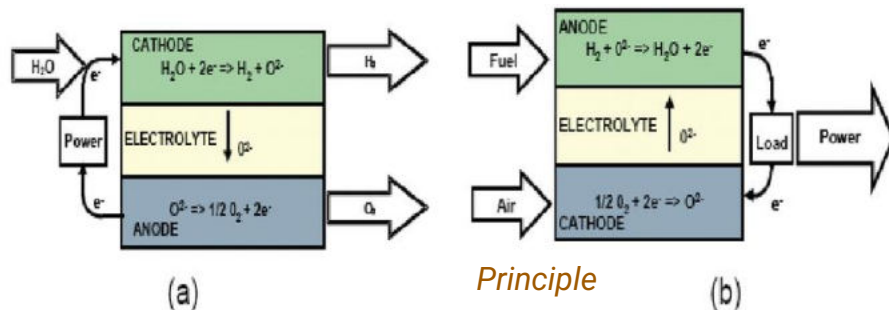

$\text{H}_2\text{O} + \text{ele} \rightarrow \text{H}_2 + 1/2 \text{O}_2$ electrolysis SOEC (a)

$\text{H}_2 + 1/2 \text{O}_2 \rightarrow \text{H}_2\text{O} + \text{ele}$ fuel cell SOFC (b)

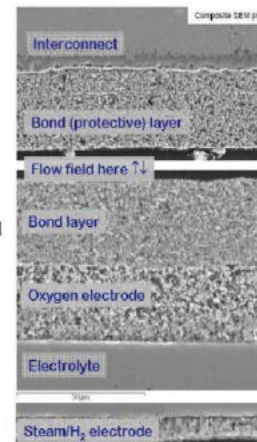
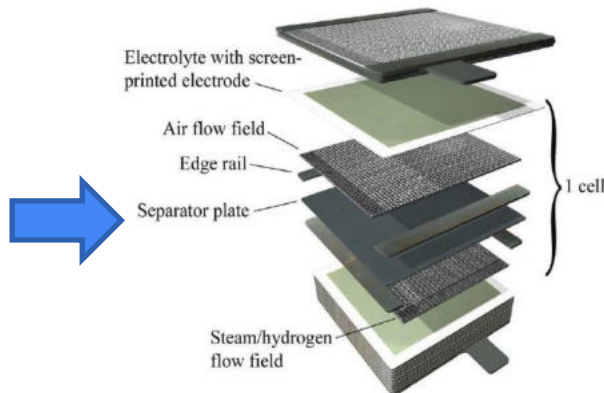
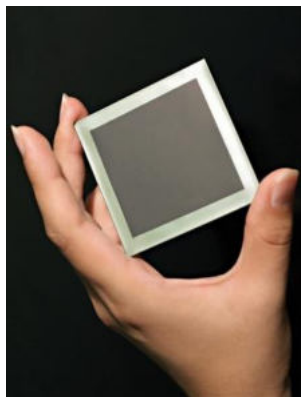

What is a cell stack?

The electrolysis / fuel cell stack is the heart of a fuel cell power system. It generates electricity (DC) / hydrogen from electrochemical reactions that take place in the fuel cell. A single fuel cell (MEA) produces less than 1 V, which is insufficient for most applications.

- MEA – Membrane-Electrode Assembly
 - Electrolyte – ionic conductor of ZrO_2 doped with 8 % Y_2O_3 (Yttrium oxide) – good strength, high melting point, corrosion resistance
 - Fuel electrode – Ni + Yttrium oxide
 - Oxygen electrode – Lanthanum Strontium Manganese (LSM) – due to high performance under electrolysis conditions
- Stack
 - Special glass or ceramic sealants
 - High-temperature sealing paste and Mica paper
 - Mechanical parts – inconel, crofer

Still relatively good availability comparing to LTE (platinum)



- Sunfire-SynLink unit
- High conversion efficiency (84 %)
- CO₂ / H₂O conversion to syngas



- Salzgitter Steel
- GrInHy 2.0 with 740 kW power
- Installed in 2020



- Cemex, Rüdersdorf
- Production of up to 5000 t of syngas since 2025
- In the realisation phase

Coupling with Gen IV reactor

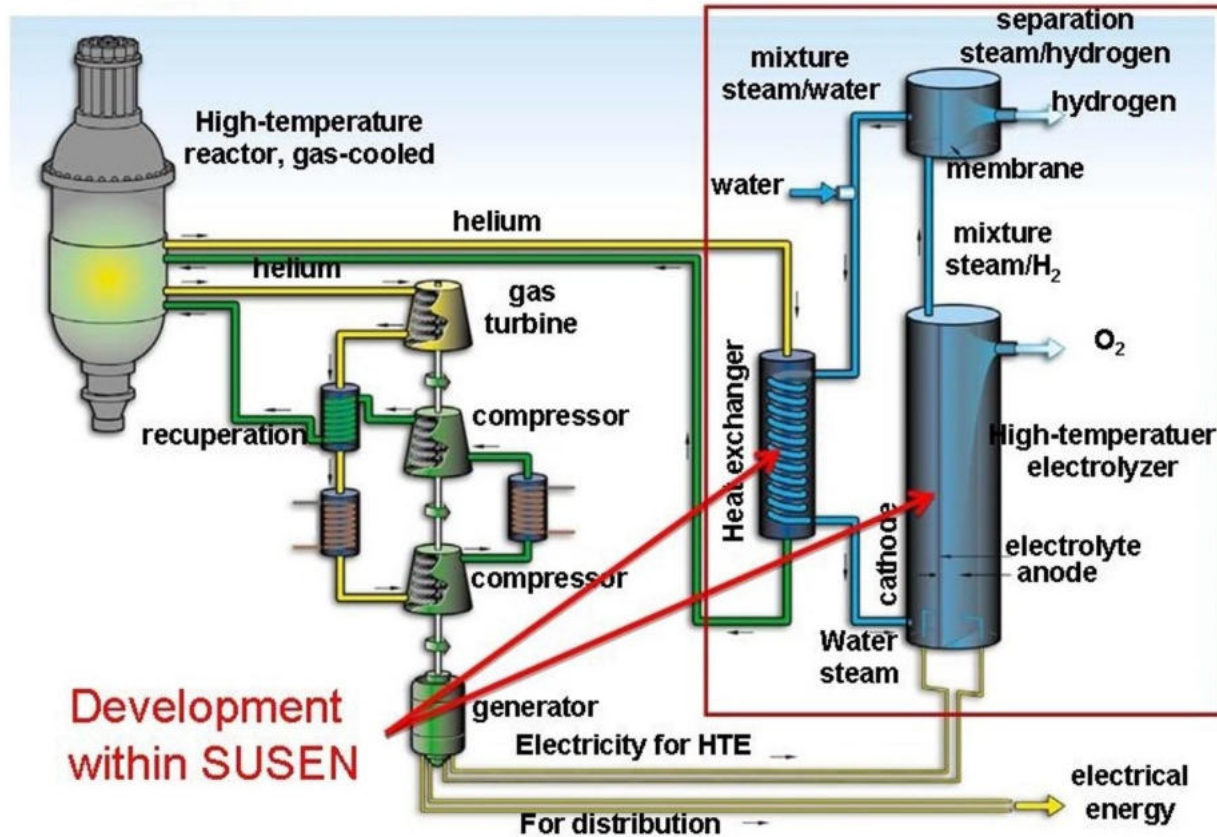

- Exposition and assessment of materials degradation at relevant conditions, lifetime assessment

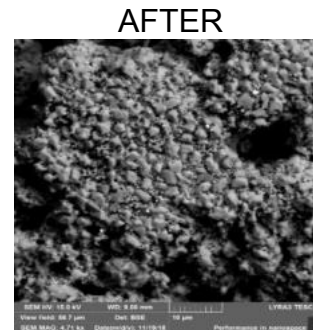
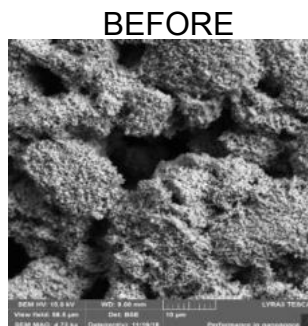
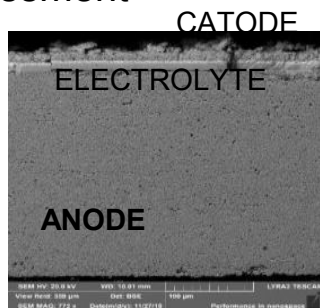

- High-temperature Hydrogen experimental loop
 - Operational temperature up to 800 °C
 - Verification of systemic behavior of HTE coupled with steam cycles
 - Air heater as a heat source, steam generator, electrolytic stack
 - H2 Production



- There are many options for how to improve stand-alone SMR performance
- For the GFR, there is a great advantage of high-temperature operation
- Individual technologies should not be competitive but should be synergic to ensure diversity and to cover various operational needs
 - Electrochemical batteries, TES, Renewables, Hydrogen, Smart Grids, ...
- Not only in GFR but basically in the whole energy sector

- CVR plans large-scale demonstration of TES energy storage with sCO₂ cycle applicable for various fields in the near future